



# SLAT

## SYNAPS PoE

Network connection interface

SYNAPS-POE 5F V 4P1C

SYNAPS-POE 5F V 4P2C



**SLAT SAS**  
7B rue Jean Elysée Dupuy  
69410 Champagne au Mont d'Or - France  
+33 4 78 66 63 60  
comm@slat.fr  
www.slat.com

**SLAT GmbH**  
Leitzstraße 45  
70469 Stuttgart – Germany  
+49 711 899 890 08  
info@slat-gmbh.de  
www.slat.com

## TABLE OF CONTENTS

		<b>Page</b>		<b>Page</b>
1	<b>LIST OF PRODUCT DESIGNATIONS</b>	4	8-3-1.Connection to the mains supply	15
2	<b>SAFETY</b>	4	8-3-2.Connection to the installation	16
3	<b>DIRECTIVES AND ENVIRONMENTAL AND PUBLIC HEALTH PROTECTION</b>	5	<b>9 COMMISSIONING</b>	17
4	<b>DEFINITION OF SYMBOLS</b>	5	9-1 Communications protocols	17
5	<b>GENERAL INFORMATION</b>	6	9-2 Installing the root certificate	17
	5-1 The company	6	9-3 Login-page - Logging onto the product	18
	5-2 Purpose of the manual	6	9-4 Configuration page - Configuring the general settings	18
	5-3 Related documentation	6	9-5 Network/Power page – Configuring the ports and output voltage	19
	5-4 Intended audience	6	9-5-1. Configuring the ports	19
	5-5 Type of notification	6	9-5-2. Configuring the output voltage	20
6	<b>THE PRODUCT</b>	7	9-5-3. Configuring the power supply	21
	6-1 Description	7	9-6 Network configuration page – IP address configuration	21
	6-2 Schematic diagram	8	9-7 Network configuration page – IP Services configuration	22
	6-3 Product views	8	9-7-1. HTTPS configuration	22
	6-4 Contents of the delivery	10	9-7-2. NTP configuration	22
7	<b>ENERGY STORAGE</b>	11	9-7-3. Syslog configuration	22
	7-1 Available storage option	11	9-7-4. SNMP protocol configuration	23
	7-2 Technology	11	9-7-5. Loading the MIB	24
8	<b>INSTALLATION</b>	12	9-8 Network configuration page – SWITCH configuration - BASIC	24
	8-1 Positioning / Installation on support	12	9-8-1. Configuring the MULTICAST	24
	8-1-1.Mast/pole-mounting	12	9-8-2. Green Ethernet configuration (EEE – Energy-Efficient Ethernet)	24
	8-1-2.Wall-mounting or pull-box mounting	13	9-9 Network configuration page – SWITCH configuration - QoS	25
	8-1-3.Fastening accessories	13	9-9-1. Port-based QoS	25
	8-2 Connection	14	9-9-2. QoS - CoS (802.1p)	25
	8-2-1.Connection specifications	14	9-9-3. QoS - DSCP	26
	8-2-2.Wiring	14		
	8-2-3.Wiring methods	15		
	8-3 Connection	15		

## TABLE OF CONTENTS

	<b>Page</b>		<b>Page</b>
9-10 Network configuration page – SWITCH configuration - VLAN	26	12 TECHNICAL DATA	39
9-11 Network configuration page – SWITCH configuration - stp/RSTP	27	12-1 Electrical characteristics	39
9-12 Network configuration page – Configuration SWITCH - 802.1x	27	12-1-1. Mains input electrical characteristics	39
9-13 Network configuration page – Configuration CA Secure	28	12-1-2. Output electrical characteristics	39
9-14 System state page - Accessing system information	28	12-2 Functional characteristics	40
9-14-1. Product description	29	12-3 Mechanical characteristics	40
9-14-2. Communication firmware version and support	29	12-4 Environmental specifications	41
9-14-3. Mains input	29	12-5 Standard specifications	41
9-14-4. SURGE ARRESTER	29	12-5-1. IEEE standards	41
9-14-5. Output	29	12-5-2. Safety standards	41
9-14-6. Product operating status	29	12-5-3. EMC standards	42
9-14-7. Operation-related data	29	12-5-4. Other standards	42
9-14-8. Charge gauge	29	13 WARRANTY AND PRODUCT RETURNS	43
9-14-9. Location	30	13-1 Warranty	43
9-15 Log page	30	13-2 Product Returns	43
9-15-1. Timestamp	30	13-2-1.Product under warranty	43
9-15-2. Events list	31	13-2-2.Product no longer under warranty	43
9-16 Restoring the factory settings	33		
9-17 Shutting down the product	33		
<b>10 OPERATION</b>	<b>34</b>		
10-1 Remote report - Communication	34		
10-2 HTTP/HTTPS protocol	34		
10-3 SNMP protocol	34		
10-4 Accessible data	36		
<b>11 MAINTENANCE AND TROUBLESHOOTING</b>	<b>38</b>		

## 1 LIST OF PRODUCT DESIGNATIONS

This user manual applies to all the products listed in the table below.

Tableau 1-1 - List of product designations

DESIGNATION	CODE
SYNAPS-POE 5F V 4P1C	89252764
SYNAPS-POE 5F V 4P2C	89452764

## 2 SAFETY

This user manual contains all the instructions for the installation, commissioning and use of the **SYNAPS PoE** power supply. Please follow it very carefully to ensure the product functions correctly.

It is vital to read the Safety Instructions before installing or commissioning this product.

### SAFETY INSTRUCTIONS

**SYNAPS PoE** is designed to be connected to the 110 - 240 V AC public mains supply which has a frequency of 45 to 65 Hz. It ensures continuity of service for equipment in the event of a power outage. The lithium battery backup function is integrated into the product.

- A disconnect switch or circuit breaker must be installed upstream in accordance with the current regulations.
- To avoid any risk of electrocution, the disconnect switch or circuit breaker must be **OPENED** before any **MAINTENANCE WORK** is carried out on the equipment.
- Work must only be carried out by qualified personnel.
- During installation, connect the ground wire first and disconnect it last when dismantling.
- Ensure the product is the right way round (see photo on page one or chapter 6-3, page 8).
- EN 62368-1 compliant (This equipment is not suitable for use in places where children are likely to be present).
- Ensure there is sufficient convection (minimum clearance 50 mm around the sides).
- The equipment is only designed to be installed on the ground or mounted on all types of pole (wood, concrete, metal) or wall.
- Size and protect the cables according to the maximum input/output current ( $\geq 0.15 \text{ mm}^2/\text{A}$ ).
- Observe the thermal and mechanical limits.
- The batteries provided are Li-ion (LiFePO4) type batteries.
- The backup is maintenance-free. Do not open it.
- Caution! There is a risk of explosion if the battery is replaced with the wrong type of battery!
- Recycle the product and its battery at the end of its life in accordance with the instructions.
- Take all the necessary precautions during installation to protect the product from water splashes.

### 3 DIRECTIVES AND ENVIRONMENTAL AND PUBLIC HEALTH PROTECTION

SLAT is committed to protecting the environment and public health through its products and complies with the corresponding directives.

SLAT designs and manufactures all its products in accordance with the environmental directives RoHS (Restriction of Hazardous Substances) and WEEE (Waste Electrical and Electronic Equipment).



Restriction  
of Hazardous  
Substances



The product must be recycled at the end of its life. The backup and its plug-in connector can be easily removed by qualified professionals independent from SLAT for recycling.

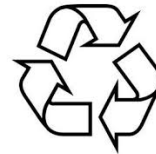

SLAT products comply with the EC directives.



### 4 DEFINITION OF SYMBOLS



Compliance of the product with the requirements of the European directives.



#### WEEE (WASTE ELECTRICAL AND ELECTRONIC EQUIPMENT)

Dispose of the product in an appropriate recovery and recycling centre. This product must not be disposed of with the household waste.



#### RoHS (RESTRICTION OF HAZARDOUS SUBSTANCES)

Compliance with the European directive restricting the use of certain hazardous substances in electrical and electronic equipment.



Ground terminal.



Caution, risk of electrocution.

## 5 GENERAL INFORMATION

### 5-1 THE COMPANY

To better satisfy its customers' expectations:

- SLAT designs and manufactures all its products according to standard ISO 14001 v15.
- SLAT recycles its products at the end of their life cycle by means of its recycling programme.

### 5-2 PURPOSE OF THE MANUAL

The user manual provides the information necessary for the positioning, connection, configuration and operation of the SYNAPS-POE equipment.

This manual is available in PDF format in MySLAT at [www.slat.com](http://www.slat.com).

### 5-3 RELATED DOCUMENTATION

The following documents are related to this user manual:

- Installation manual
- Commercial brochure

This documentation is available at [www.slat.com](http://www.slat.com).

### 5-4 INTENDED AUDIENCE

The operations and information described in this manual must only be performed by authorised, trained operators.

### 5-5 TYPE OF NOTIFICATION

Three types of important notifications are used in this manual. The type of notification informs you of the potential consequences of non-compliance with the instructions.

These consequences are not exhaustive and are listed in order of increasing risk.



#### **IMPORTANT REMARK!**

Contains additional information. Non-compliance will not cause damage to equipment or injury.



#### **CAUTION!**

Equipment and property may be seriously damaged or people may be seriously injured if the precautions for use are not followed.



#### **DANGER!**

Failure to comply with the notification may lead to serious injury or death.

## 6 THE PRODUCT

### 6-1 DESCRIPTION

SYNAPS PoE 5F V 4P1C / 4P2C is a network connection interface.

SYNAPS is installed as close as possible to the applications and offers every benefit to optimise wiring and simplify maintenance. It also enables selective electrical protection of the applications

SYNAPS PoE is an outdoor network interface box designed for video applications and their transmission powered by PoE. All the conversion functions are present in this box to adapt the supply voltage to the needs of the connected equipment, to convert the data transmission media and even to switch the various equipment to the Ethernet network. In the event of a power outage or glitch, it ensures continuity of service for the equipment it protects with its integrated Li-ion battery.

#### Built-in functions

- Supplies up to 150 W in Power Over Ethernet
- Powers equipment via PoE up to 90 W
- Manageable 5-port layer 2 switch
- Secure webserver and SNMP agent
- Optical fibre link for remote connection
- Configurable auxiliary voltage: 12 V DC or 24 V DC
- Configurable automatic restart for each port
- 10 kA (4P1C version) 40 kA (4P2C version) surge arrester for lightning strikes
- Filters interference from the electrical grid
- Webserver function for supervision and configuration
- Fastening accessories for customer equipment

#### Benefits of SYNAPS PoE

- Transmits data by optical fibre
- Manages video streams via its numerous dedicated functions
- Ensures 24/7 operation
- Ultra compact and lightweight product
- Eliminates short power cuts and provides emergency power adapted to your needs
- Provides first-level maintenance thanks to an automatic reboot in the event of an unexpected shutdown.
- Monitors the entire installation remotely with a secure connection.
- Protects connected equipment against lightning and electromagnetic disturbances.
- Uses LFT battery technology with a very long service life.
- Space available for customer equipment.
- Designed for outdoors with IK10 vandal-proof IP 65 sealed enclosure and key lock.



### 6-2 SCHEMATIC DIAGRAM

The image below shows the schematic diagram for the product.

Figure 6-1 - Schematic diagram

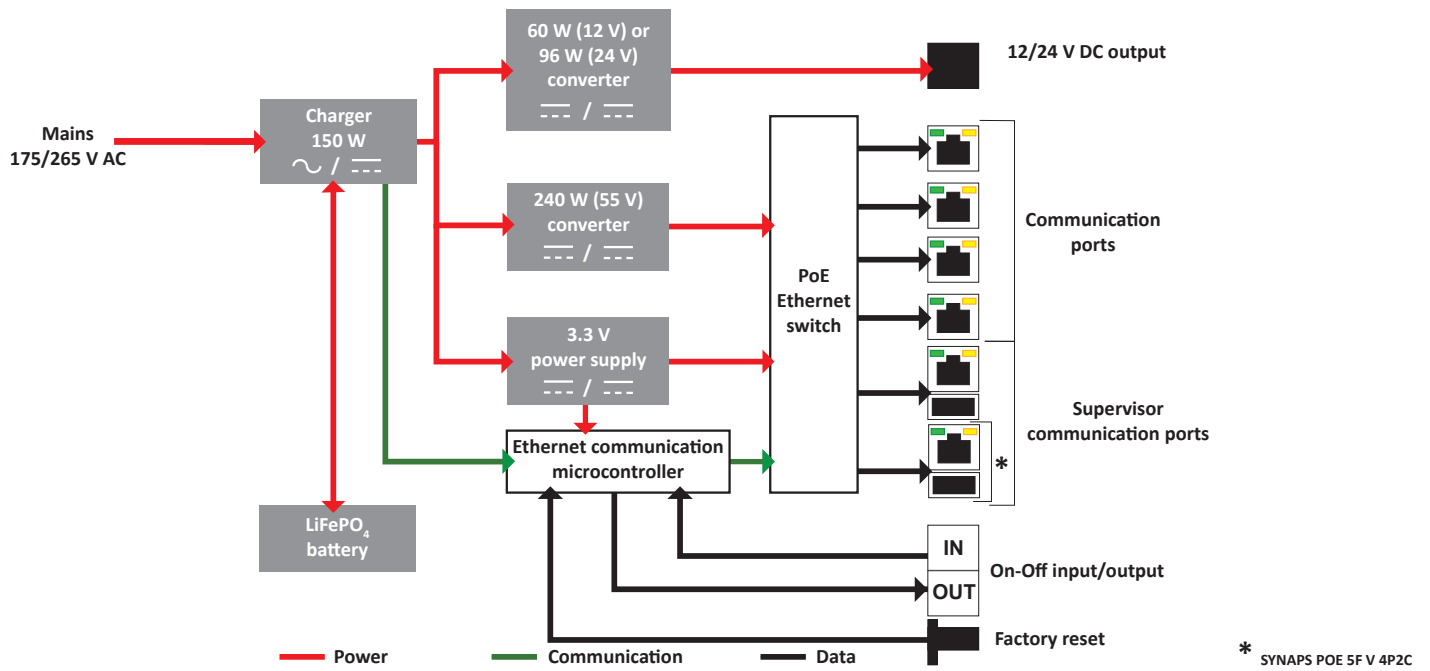

### 6-3 PRODUCT VIEWS

Figure 6-2 - Exterior view

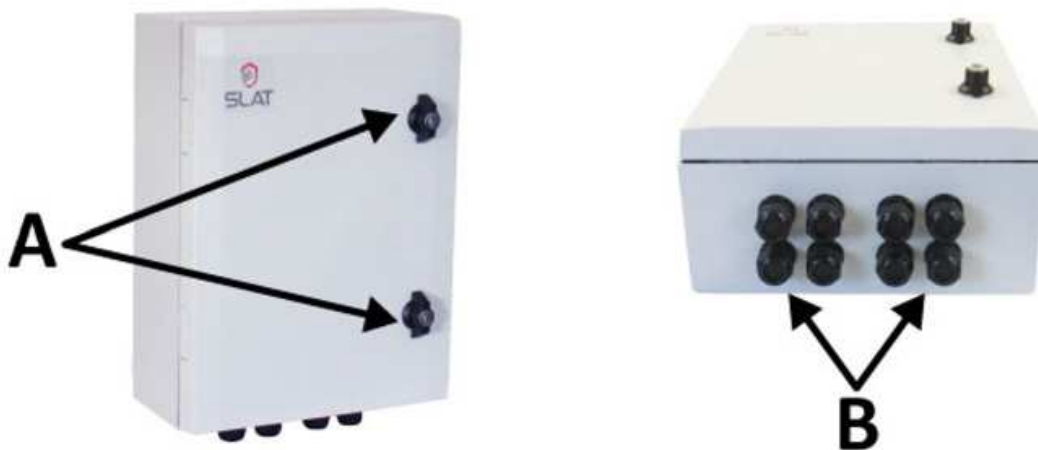

Figure 6-3 - View of the inside of the cabinet

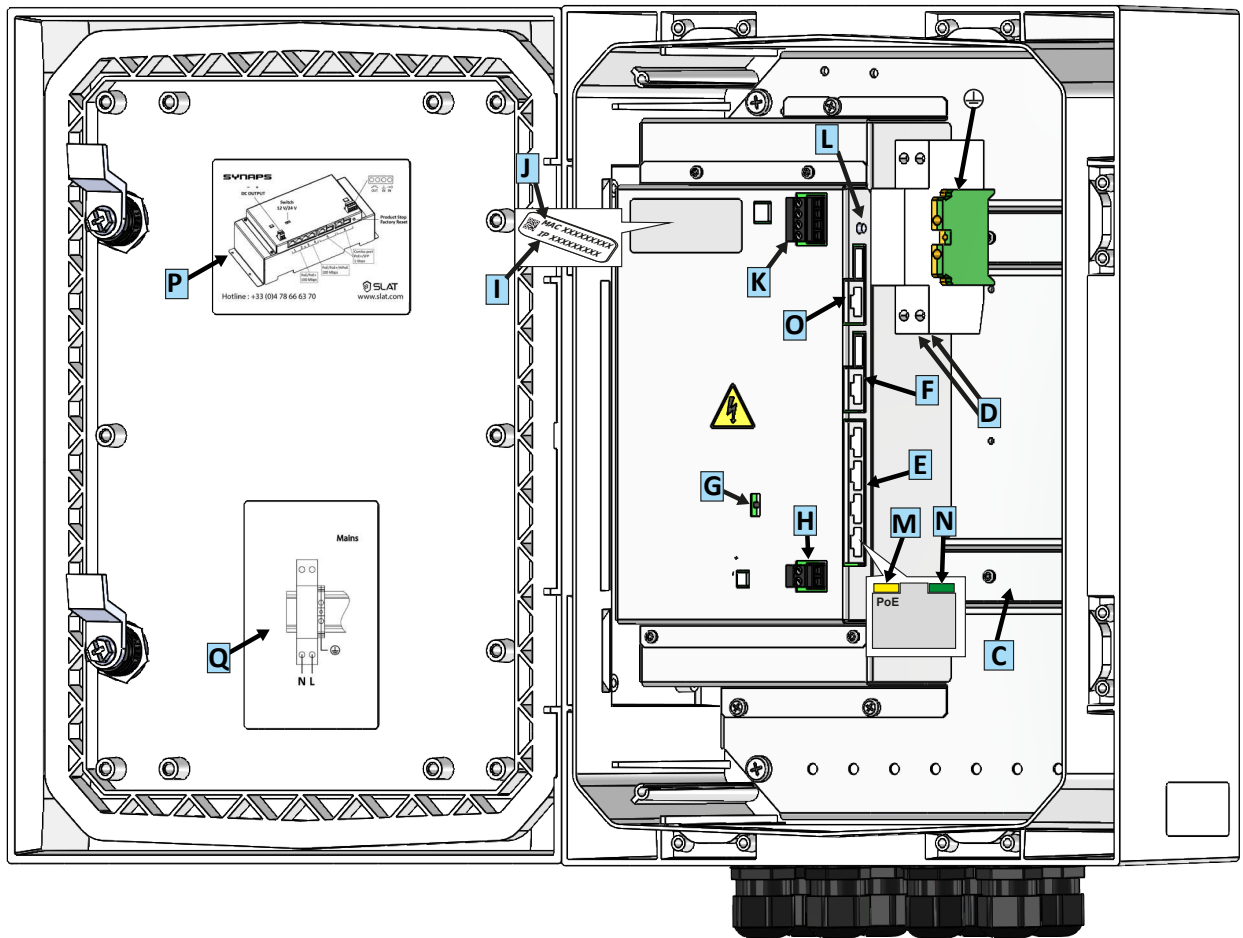

Figure 6-4 - SURGE ARRESTER



Tableau 6-1 - Key and location of the components

	NAME	USE
<b>A</b>	Handle with key lock	Door opening/closing and protection with key.
<b>B</b>	Cable gland	Cable feedthrough for all cables including RJ45 cables and optical fibre.
<b>C</b>	DIN rail	Mounting of customer equipment.
<b>D</b>	Surge arrester	230 V AC mains input on the surge arrester screw terminal block.
<b>E</b>	Ethernet ports	Ports 1 and 2: 10/100 Mbps PoE / PoE+ / PoE 55 V PSE Ports 3 and 4: 10/100 Mbps PoE / PoE+ / HiPoE / PoE 55 V PSE
<b>F</b>	Combo port (RJ45/SFP)	10/100/1000 Mbps combo port The RJ45 port is PoE / PoE+ / PoE 12 V / PoE 24 V / PoE 55 V PSE
<b>G</b>	DC switch	Used to select the DC output voltage value (12 V or 24 V).
<b>H</b>	DC output	User voltage output: 12 V DC or 24 V DC.
<b>I</b>	IP address*	Default IP address. Identifies the SYNAPS over the IP network.
<b>J</b>	MAC address*	Identifies the SYNAPS over the IP network.
<b>K</b>	Alarm report	Alarm report terminal block by IN and OUT dry contact
<b>L</b>	LED/Reset button	Product shut-down if mains absent (short press) / Reset of all the SYNAPS factory settings (long press)
<b>M</b>	PoE LED	PoE voltage present
<b>N</b>	Link LED	Ethernet link status: Green, optimum link speed (100 Mbps for ports 1 to 4, 1000 Mbps for the combo port). Orange, link established. Flickers according to the traffic. Off, no Ethernet link.
<b>O</b>	Combo port (RJ45/SFP)	SYNAPS POE 5F V 4P2C version: - 10/100/1000 Mbps combo port - The RJ45 port is PoE / PoE+ / PoE 12 V / PoE 24 V / PoE 55 V PSE
<b>P</b>	Connection label	SYNAPS board connection label
<b>Q</b>	Mains label	Mains connection

\*The QR code on the label is used to read the MAC address and the default IP address.

## 6-4 CONTENTS OF THE DELIVERY

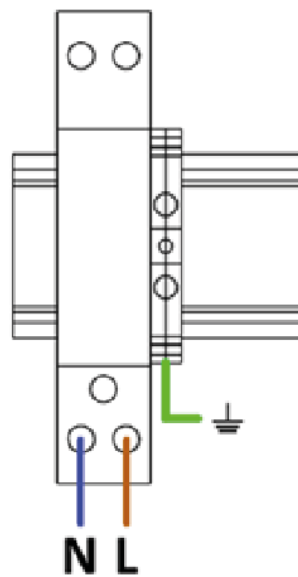
The product is delivered with:

- ➡ 1 installation manual



## 7 ENERGY STORAGE

### 7-1 AVAILABLE STORAGE OPTION

SLAT products are combined with batteries or backup systems. They are used as emergency power supplies if the mains supply is cut off. The available autonomy then depends on the capacity of the built-in backup.

### 7-2 TECHNOLOGY

The battery uses lithium iron phosphate technology (LiFePO<sub>4</sub>). LiFePO<sub>4</sub> offers the best safety characteristics of any lithium storage system (Figure 7-1). This includes better resistance to impacts and to extreme temperatures.

Figure 7-1 - LiFePO<sub>4</sub> features

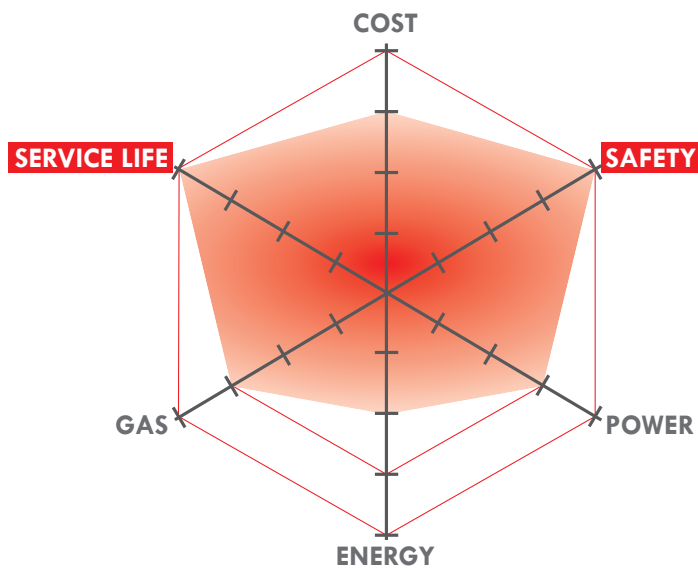

- The SYNAPS battery has the following features:
- Lithium iron phosphate technology (LiFePO<sub>4</sub>)
  - No risk of thermal runaway
  - Storage for 9 months without recharging
  - 10-year service life at 25°C
  - Lead-free, cadmium-free, 100% recyclable

## 8 INSTALLATION

The product must be installed in accordance with the EN 62368-1 safety standard.

### 8-1 POSITIONING / INSTALLATION ON SUPPORT

The SYNAPS is designed to be installed vertically on a wall, in a pull-box or on a mast/pole.

#### 8-1-1.Mast/pole-mounting

➔ Mount using the SYNAPS MP HIGH BOX SST kit (not supplied).

1. Mount the kit on the product using a bit screwdriver [ $\frac{1}{4}$ " socket and  $\frac{1}{4}$ " hex bit (H6)].
2. Attach the product to the pole using the clamps not supplied in the kit ( $\varnothing$  min. 100 – max. 300 mm) (Figure 8-1).

Figure 8-1 illustrates how the mounting kit should be fitted to the cabinet and positioned on the pole.

The installer is responsible for checking the load capacity of the mast/pole.

Figure 8-1 - Mast/pole-mounting

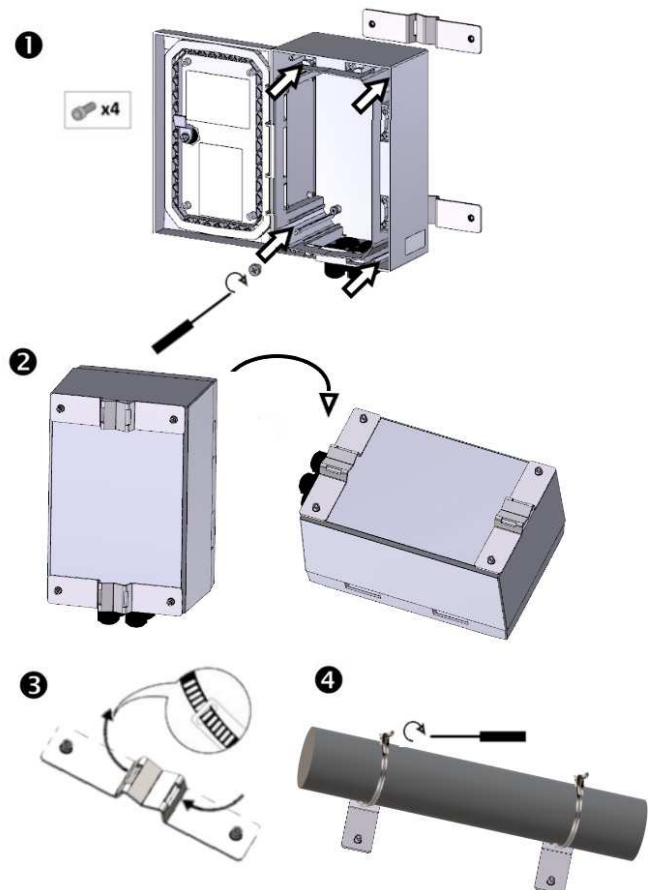

### 8-1-2. Wall-mounting or pull-box mounting

The SYNAPS wall-mounting kit (ref. 700200011) (not supplied) can be used for easy installation (see NOT210002), or proceed as shown in Figure 8-2.

Cooling the product by natural convection requires a minimum clearance of 50 mm on each side. Comply with the thermal and mechanical limits (Figure 8-2).

1. Place the product on a concrete substrate for example, and mark the fastening points A = 260 mm B = 360 mm.
2. Drill the substrate and insert suitable plugs\* (not supplied) into the substrate.
3. Attach the product using screws\* (not supplied).
4. Use washers (not provided) with a diameter of 10 mm.

\*Slat recommends using  $\varnothing 5 \times 50$  mm screws and  $\varnothing 6 \times 50$  mm plugs for a concrete substrate.

Figure 8-2 - Wall-mounting or pull-box mounting

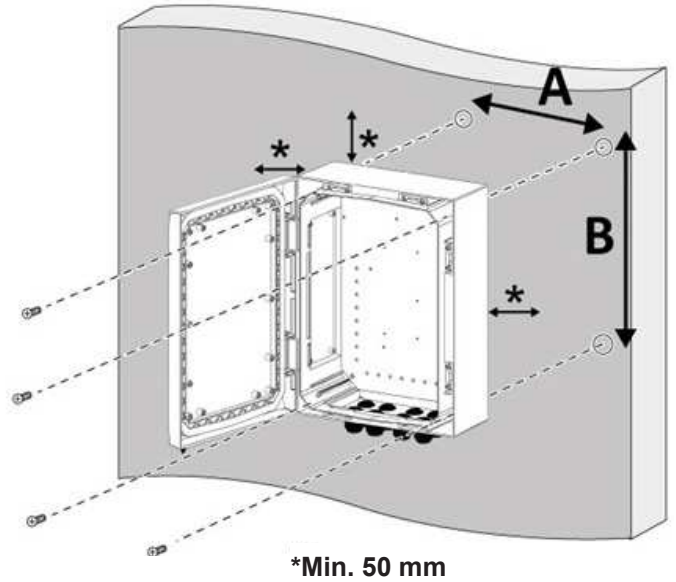

**N.B. The following tools will be required for installation:**

- 1 T 25 Torx spanner
- 1 flat 3 mm screwdriver
- Steel strapping, size 10 or 20 for pole fastening.
- 1 T10 Torx spanner

### 8-1-3. Fastening accessories

- The mast/pole-mounting kit (optional)



- The wall-mounting kit (optional)



## 8-2 CONNECTION

### 8-2-1. Connection specifications

Tableau 8-1 - Connection specifications

			CROSS-SECTION
Mains/surge arrester		AC power cable (L/N/Pe) - length to be stripped 7 mm tightening torque 0.5 to 0.6 Nm	0.5 to 2.5 mm <sup>2</sup>
User output		DC power cable (+/-) - length to be stripped 7 mm - screw terminal block, plug-in connector - tightening torque 0.5 to 0.6 Nm	0.5 to 2.5 mm <sup>2</sup>
On-Off input/output		Cable for on-off input/output - length to be stripped 7 mm - screw terminal block, plug-in connector - tightening torque 0.5 to 0.6 Nm	0.5 to 1.5 mm <sup>2</sup>
Ethernet ports 1 to 4		Shielded Ethernet cable only, straight-through or crossover cable	Cat. 5 or more
Combo port	RJ45 port	Shielded Ethernet cable only, straight-through or crossover cable	Cat. 5e or more
	SFP port	Optical fibre/SFP-transceiver module 1 Gbps	



#### **DANGER!**

The cable cross-section used must be selected according to the operating current ( $\geq 0.15 \text{ mm}^2/\text{A}$ ).

### 8-2-2. Wiring

After installing the product on its bracket, the wiring must be carried out.

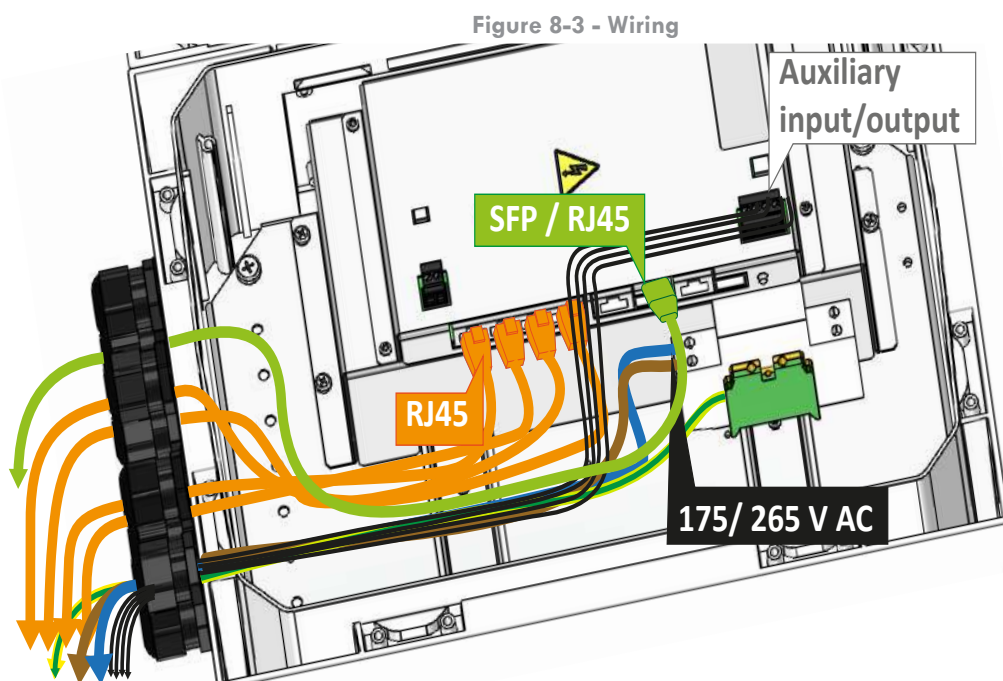

#### **CAUTION!**

Risk of tripping the surge arrester if live and neutral are reversed.

### 8-2-3. Wiring methods

Connect the wires and the RJ45s according to the symbols shown on the labels (flat screwdriver for screw terminals).



#### CAUTION!

Comply with the screw tightening torque recommended in “Tableau 8-1 - Connection specifications”, page 14 to avoid breaking the terminals.

To avoid wiring mistakes, make a careful note of the positioning of the connectors and terminal blocks and their respective symbols.

All the RJ45 Ethernet ports are auto MDI-X ports so straight-through or crossed cables can be used.

### 8-3 CONNECTION



#### DANGER!

The application must be switched off in order to connect the equipment.

The circuit breaker upstream of the application must be open!

The stripped ends of the mains cables must be crimped before being connected to the product terminals!

Always connect the ground wire first before connecting the power supply to the mains!

The wires are connected according to the following steps:

#### 8-3-1. Connection to the mains supply

The mains input cables must be connected to the surge arrester terminal block (Figure 8-4, page 15). Connect the three wires according their colour:

- Yellow/green - ground wire (⊕)
- Blue - neutral wire (N)
- Brown - live wire (L)

After connecting the ground wire, the “neutral” and “live” wires can be connected. Connect through the cable glands (C, Figure 6-2, page 8).

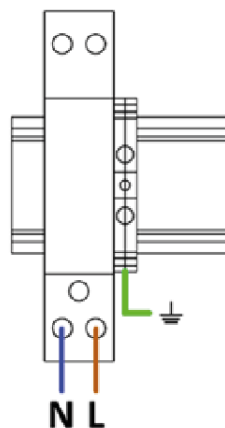

Figure 8-4 - Mains connection

### 8-3-2. Connection to the installation

- 12/24 V DC power supply:

The equipment can be powered by 12 V DC or 24 V DC via the screw terminal block (H, Figure 6-3, page 9). Select the DC output voltage using the DC switch (in 12 V DC by default) (G, Figure 6-3, page 9).

- On-off input/output:

With the screw terminal block (K, Figure 6-3, page 9), the SYNAPS PoE has an on-off input to interface with a voltage-free dry contact and an open collector type on-off output. The system operates using SNMP via bits 30 and 31 of the **systemState** variable (see “Tableau 10-3 - Details of the systemState variable”, page 36).

- Communication:

The 4 Ethernet ports (E on Figure 6-3, page 9) are used to connect to the product in 10/100 Mbps. They are numbered on the product and can be used indifferently.

Ports 1 and 2 are PoE / PoE+ / PoE 55 V PSE whereas ports 3 and 4 are PoE / PoE+ / HiPoE / PoE 55 V PSE.

- Communication with the supervisor:

Connect the combo port (RJ45 or SFP) (F on Figure 6-3, page 9).

The combo port (RJ45/SFP) creates the connection for communication with the supervisor. The communication speed is 10/100/1000 Mbps. The combo port in Ethernet is PoE / PoE+ / PoE 12 V / PoE 24 V / PoE 55 V PSE.

**N.B.** The RJ45 connector latching tab should be positioned towards the front.

Once the connections are complete, the upstream circuit breaker can be closed, then close and lock the customer access door.

## 9 COMMISSIONING

When the SYNAPS-PoE is in operation, all the PoE LEDs light up for a few seconds during initialisation, then they go out. This means that the product is correctly powered and ready to function.

The communication parameters can be configured via the HTTPS website.

In order to communicate with the product, it must be configured according to the following chapters. The configuration of the network of the computer to which the product will be connected must be compatible with the product's network parameters.

### 9-1 COMMUNICATIONS PROTOCOLS

The communications protocols supported by the product are as follows. They can run simultaneously. Therefore it is not necessary to select a single active protocol.

**Application protocols**   ➔ HTTP/HTTPS   ➔ SNMP v1, v2c or v3   ➔ Syslog

**Network protocols**   ➔ ICMP   ➔ NTP   ➔ QoS   ➔ IGMP   ➔ 802.1x

### 9-2 INSTALLING THE ROOT CERTIFICATE

To use the products in HTTPS and communicate safely with them, the SLAT root certificate must be installed on the user's computer. This certificate is valid for all SLAT products and can be downloaded from [www.slat.com/telechargements](http://www.slat.com/telechargements).

**The root certificate is called SLAT\_ca\_cert.crt**

The certificate must be installed in the certificate store: "Trusted root certification authorities".

Figure 9-1 - Selecting the certificate store

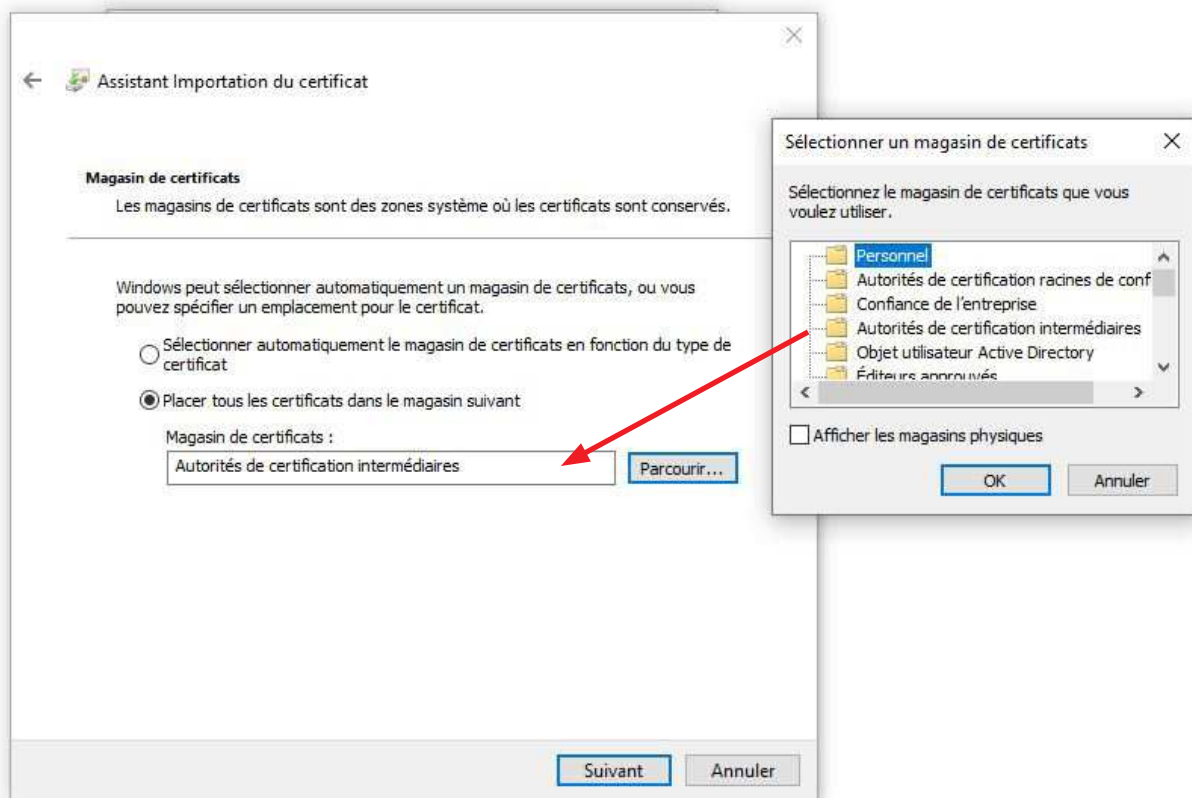

### 9-3 LOGIN-PAGE - LOGGING ONTO THE PRODUCT

Figure 9-2 - Login page

Use the IP address given on the product (see Figure 6-3, page 9) to log in and configure the installation using a web browser (over HTTPS). The language used for the login page is that of the web browser. It is possible to “ping” the SYNAPS from the command prompt to find the product without its IP address if only one product is available.



#### IMPORTANT REMARK!

The default login and password are:

Login: admin

There is no password. Click directly on “OK”.

It is essential to set a password for the security of your installation!

Once connection with the product has been established, the “**System State**” page opens (see 9-14, page 28). If no password has been set, the “**Configuration**” page opens (see 9-4, page 18) and a message informs you that a password needs to be set. The default language of the embedded website’s administrator is English.

### 9-4 CONFIGURATION PAGE - CONFIGURING THE GENERAL SETTINGS

Figure 9-3 - Configuration page

To configure the product, click on the “**Configuration**” tab in the left-hand menu. This page is used to perform the following configuration operations. Confirm the operations using the following buttons (“OK”, “Add”, “Delete”, “Update”).

#### 1. Change language

#### 2. Change password

#### 3. Add user

Up to 8 users (including the administrator) can be created. When a user account is created, it is in the same language as that of the administrator. It can be changed if necessary.

A new user does not need to enter a password. The first time the new user logs in, they will be invited to define a password via the “**Configuration**” page.

#### 4. Delete user

Select a user in the drop-down menu and click the “Delete” button.

#### 5. Enter the system name

A name with up to 16 characters can be entered for the system. Over HTTPS, the name is always displayed with the prefix “SYNAPS”. This information is also available over SNMP but without the prefix.

#### 6. Enter the product location

The location defined here is shown on the “System State” page (see 9-14, page 28). This information is also accessible over SNMP.

#### 7. Update the firmware (communication)

The communication firmware can be updated to add new functions. The current version is displayed in the top right-hand corner of the page.

Operations 1 and 2 can be performed by all the accounts (administrator and users). However, operations 3 to 7 can only be accessed by the administrator.

### 9-5 NETWORK/POWER PAGE – CONFIGURING THE PORTS AND OUTPUT VOLTAGE

Figure 9-4 - Network/Power page

The screenshot displays the SYNAPS Network/Power configuration page. On the left is a navigation menu with options: > System State, > Network / Power (selected), > Log, > Network Configuration, > Configuration, and > Disconnection. The main content area is titled 'Network/Power' and contains a table with the following data:

Port	Link	IP Address	PoE	DAM	
Port1	-	0.0.0.0	PoE 802.3: Standby	Off	OK
Port2	-	0.0.0.0	PoE 802.3: Standby	Off	OK
Port3	-	0.0.0.0	PoE 802.3: Standby	Off	OK
Port4	-	0.0.0.0	PoE 802.3: Standby	Off	OK
Port5	1000BASE-T	0.0.0.0	PoE 802.3: Standby	Off	OK

Below the table, the DC Output section shows: Voltage 24 V, Measurements 24.2 V, and 0.2 W. A Restart button is present. The Power Supply section shows Battery Capacity at 60 Wh, Stealth Mode Threshold set to Disabled, and Eco Mode Threshold set to Disabled.

This page is accessed by clicking on the “Network/Power” tab in the left-hand menu. It is used to check and display all the information concerning each Ethernet port (e.g., Connected ports, IP address) and the information concerning the DC output.

The administrator can access and edit all the information. Users can only view the information concerning each port (9-5-1, page 19) and the output voltage (9-5-2, page 20).

The information is automatically refreshed every 5 seconds, except when an edit operation is in progress.

#### 9-5-1. Configuring the ports

The table (Figure 9-4, page 19) shows the configuration and state of each of the ports on the SYNAPS-PoE.

To save changes made to a port, click on “OK” to the right of the same line.

##### ➡ Port

This column contains the port identifier. It can be customised as required by entering a name of up to 11 characters in the right-hand box.

If an IP address has been entered in the “IP Address” column, then the word “Port X” becomes a hypertext link to this same IP address ([Port X](#)).

### ↻ Link

This column indicates whether an Ethernet link has been established, displaying its connection speed and its type:

Ports 1 to 4: 10 or 100 Mbps

Port 5: 10, 100 Mbps or 1 Gbps

### ↻ IP address

This field is used to enter an IP address. If this IP address is different to “0.0.0.0”, it changes the “Port X” identifier to a hypertext link to this same IP address. This gives instant access to the peripheral connected to this port.

### ↻ PoE

This field indicates the PoE status and any consumption. It is also used to pilot and configure it, either:

- in PoE 802.3 mode (PoE / PoE+ /HiPoE power negotiation),
- in PoE 55 V mode (no negotiation, 55 V continuously supplied),
- in PoE 12 V mode (if DC output configured in 12 V) (no negotiation, 12 V continuously supplied),
- in PoE 24 V mode (if DC output configured in 24 V) (no negotiation, 24 V continuously supplied).

	PoE	PoE+	HiPoE	PoE 12 V	PoE 24 V	PoE 55 V
Port 1	X	X				X
Port 2	X	X				X
Port 3	X	X	X			X
Port 4	X	X	X			X
Port 5	X	X		X	X	X

In PoE 802.3 mode, when a PoE port is ready to function without a connected application, the indicated status is “Standby”. By connecting an application to a port, a PoE budget for this port is negotiated (“Starting”). The PoE class defines a power range (maximum 15.4 W for PoE, 30 W for PoE+ and 90 W for HiPoE). Once the negotiation has finished, the power consumption is indicated in this field.

In PoE 55 V mode, the maximum available power is 30 W. There is no negotiation: 55 V is continuously supplied and the consumed power is displayed in real time.

In PoE 12 V or PoE 24 V mode, the maximum available current is 1 A. There is no negotiation: 12 V or 24 V is continuously supplied (depending on the DC output configuration) and the consumed power is displayed in real time.

It is also possible to manually restart the PoE for each port (“Restart”): The PoE power supply stops for 8 seconds and restarts automatically. In 802.3 mode, it stays in standby while waiting for a new negotiation (like when a new application is connected to the product).

### ↻ DAM (Device Activity Monitoring)

This field is used to control the DAM (Device Activity Monitoring) function which authorises individual surveillance of the application connected for each port. The administrator can disable this function (“Stop”) or activate it in PoE mode (“PoE DAM”) or in DC output mode (“DC DAM”). It is disabled by default.

Once the function is active, it remains on standby waiting for the connected application to start and answer regularly sent queries. As soon as the application has started, it answers the queries and thus activates DAM supervision and protection of the application. If the application no longer answers, the DAM launches an automatic restart either of the corresponding PoE port in PoE DAM mode, or of the DC output in DC DAM mode.

For the DAM function to operate, the connected application’s IP address must be entered in the “IP Address” field.

## 9-5-2. Configuring the output voltage

The output voltage can be modified manually using the switch (G, Figure 6-3, page 9). The DC output presents its configuration (12 V or 24 V), its effective voltage measurement and the consumed power.

It is also possible to restart the DC output manually by clicking on the “Restart” button: The DC output stops for 8 seconds and restarts automatically.

### 9-5-3. Configuring the power supply

#### ↻ Battery capacity

The capacity displayed is the battery's minimum capacity. The value is given for information purposes and cannot be changed. It differs from the typical value for the capacity given on the product label.

#### ↻ Stealth mode threshold

Stealth mode enables the supervision to stop product consumption to relieve network load. The product automatically switches to normal operation once the remaining autonomy has reached the guaranteed autonomy percentage selected by the administrator during configuration.

To enable the stealth mode, the threshold (percentage of the guaranteed autonomy when stealth mode is used) must be defined: 25% / 50% / 75% / Disabled. Click on "OK" to the right to save the new threshold.

#### ↻ Eco mode threshold

When enabled, eco mode improves power efficiency at low charge (<20% of I<sub>max</sub>), while guaranteeing a defined percentage of autonomy. Eco mode is disabled by default in the factory settings.

To enable eco mode, the threshold (percentage of the autonomy that must remain available to the user) must be defined: 50% / 60% / 70% / 80% / Disabled. Click on "OK" to the right to save the new threshold.

## 9-6 NETWORK CONFIGURATION PAGE – IP ADDRESS CONFIGURATION

Figure 9-5 - Network Configuration Page – IP address

The screenshot shows the SYNAPS web interface for IP Address configuration. The page title is "SYNAPS" and the firmware version is "Firmware V2.2.1.4 Support". The left sidebar contains a navigation menu with the following items: > System State, > Network / Power, > Log, > Network Configuration (expanded), > IP Address (highlighted in red), > IP Services, > Switch - Basic, > Switch - QoS, and > Switch - VLAN. The main content area is titled "IP Address" and contains the following settings:

- DHCP:
- System IP Address:
- Network Mask:
- Gateway IP Address:

The DHCP (dynamic IP address allocation) automatically assigns an IP address to a product in order to communicate with it. This feature is enabled by default in the factory configuration.

There are two operating modes depending on the availability or lack of a DHCP server on the network:

#### A. DHCP server available

If a DHCP server is available, it allocates an IP address to the product. If several products are connected to the network, it allocates a different IP address to each one.

Browse the network to determine the new address.

#### B. DHCP server unavailable

If no DHCP server is available on the network, the product uses the IP parameters below. When the product connects to the network for the first time, it waits for 15 seconds before using the predefined IP address but continues to send DHCP requests periodically.

In this case, if several products need to be connected to the same network, as they all have the same IP parameters, they must be isolated and the IP address of each product must be modified with the HTTPS web interface before being connected to the network in order to avoid any IP address conflicts. The same procedure is valid if the same IP address exists several times on a given network.

The product's IP parameters consist of the IP address, network mask and gateway IP address. The default IP and MAC addresses are visible on the label near the surge arrester.

These parameters are entered manually in the fields (IP address of the product, network mask, gateway IP address). If the gateway feature is to be disabled, enter the gateway IP address “0.0.0.0”. Click on “OK” next to “Gateway IP address” to save the configuration. The user is automatically re-routed to the new address (login page).

## 9-7 NETWORK CONFIGURATION PAGE – IP SERVICES CONFIGURATION

Figure 9-6 - Network Configuration Page – IP services

The screenshot displays the 'IP Services' configuration page in the SYNAPS interface. On the left, a sidebar lists navigation options: System State, Network / Power, Log, Network Configuration (expanded), IP Address, IP Services (highlighted in red), Switch - Basic, Switch - QoS, Switch - VLAN, Switch - STP/RSTP, and Switch - 802.1x. The main content area is titled 'IP Services' and includes the following settings:

- HTTPS:** A checkbox is checked, with an 'OK' button to its right.
- NTP:**
  - Server IP Address #1: 0.0.0.0
  - Server IP Address #2: 0.0.0.0
  - System Timezone Offset (minutes): 0, with an 'OK' button to its right.
- SysLog:** Event Severity is set to 'Disabled' via a dropdown menu, with an 'OK' button to its right.
- SNMP:** Mode is set to 'V1 - Read-Only' via a dropdown menu, with an 'OK' button to its right. Below this, two server IP addresses are listed as 0.0.0.0, each with an 'OK' button to its right.

A link labeled 'SNMP MIB Download' is located at the bottom of the configuration area.

### 9-7-1. HTTPS configuration

To use the products over HTTPS, check the box on the right of HTTPS and press OK.

The SLAT root certificate must be installed on the user's computer beforehand (see 9-2, page 17). Navigation over HTTP is faster but not secure. For this, uncheck the box and press OK.

### 9-7-2. NTP configuration

The NTP (Network Time Protocol) servers are used to synchronise the system clock. Proceed as follows:

- Enter the IP address of one or two NTP servers to obtain UTC time.
- Enter the offset in minutes between the system time zone and the UTC time to correctly date events. The value range in minutes can be from -720 to +720, which covers all time zones.
- To save the settings, press “OK” to the right of the “System Timezone Offset” line.

### 9-7-3. Syslog configuration

The product is able to send events via UDP / 514 to one or two Syslog servers (RFC 5424 and RFC 5426). Enter the level of severity of the events to be sent and the IP address(es) of the servers.

- Select the “Event Severity” with the drop-down menu.
- Enter the IP address of one or two Syslog servers
- To save the settings, press “OK” to the right of the “Server No.2 IP address” line.

Tableau 9-1 - Event severity level

LEVEL	DESCRIPTION	EVENT SEVERITY			
		ALL	<5	<4	DISABLED
0	Emergency	X	X	X	
1	Alert	X	X	X	
2	Critical	X	X	X	
3	Error	X	X	X	
4	Warning	X	X		
5	Notice	X			
6	Informational	X			

The category code (Facility) used for the priority of SysLog messages is 1.

#### 9-7-4. SNMP protocol configuration



The product supports SNMP versions V1, V2c and V3. The SNMP protocol can operate in one of the following modes:

- Read/Write  
The data is accessible in read and write mode. Actions can be implemented.
- Read Only (by default)  
The data is only accessible in read mode.
- Disabled  
The SNMP protocol is disabled.

SNMP V1 and V2c: Click on "OK" to the right of "SNMP" to save the configuration.

SNMP V3:

- USM User  
Create a login.
- Auth Algorithm  
Choose the algorithm to hash the password corresponding to the login.
- Auth Password  
Enter a password of between 8 and 16 characters.
- Privacy Algorithm  
Choose the encryption algorithm.

### ➤ Privacy Password

Enter an encryption code of between 8 and 16 characters.

Click on “OK” to the right of “Privacy Password” to save the configuration.

If the user wishes to receive SNMP traps, they must configure the IP address of the SNMP servers receiving them. One or two SNMP servers can be entered.

To save changes, click on “OK” to the right of the same line.

If the feature is to be disabled, enter the IP address “0.0.0.0”.

### 9-7-5. Loading the MIB

The SNMP MIB (Management Information Base) of the product can be downloaded via the link “Load the SNMP MIB” (see Figure 9-6, page 22). If the download does not start, check that it is not blocked by the web browser.

## 9-8 NETWORK CONFIGURATION PAGE – SWITCH CONFIGURATION - BASIC

Figure 9-7 - Network Configuration Page - Switch - Basic

The screenshot displays the SYNAPS web interface for the 'Switch - Basic' configuration page. On the left, a navigation sidebar lists various system and network settings, with 'Switch - Basic' highlighted in red. The main content area is titled 'Switch - Basic' and contains two configuration options: 'Multicast:' with a dropdown menu currently set to 'Unmanaged', and 'Green Ethernet (EEE):' with an unchecked checkbox and an 'OK' button to its right. The top right corner of the interface indicates the firmware version as 'Firmware V2.2.1.4 Support'.

### 9-8-1. Configuring the MULTICAST

The switch can function according to three modes to manage Multicast frames:

- Unmanaged, the Multicast frames are considered to be Broadcast frames: they are broadcast on all the product’s ports.
- Uplink mode, the Multicast frames can only leave via the combo ports (port 5 and port 6).
- IGMP snooping, the Multicast frames only leave via the ports where they have been requested. This takes place automatically thanks to the information contained in them.

In the drop-down list, select the frame management mode then press “OK” to the right of the same line.

### 9-8-2. Green Ethernet configuration (EEE – Energy-Efficient Ethernet)

The Green Ethernet function makes it possible to automatically reduce the power consumption of an Ethernet link depending to its usage. To configure Green Ethernet, check or uncheck the box then click “OK” to the right of the same line.

Some incompatibilities can cause the Ethernet link to be unstable. In this case you are advised to disable Green Ethernet.

## 9-9 NETWORK CONFIGURATION PAGE – SWITCH CONFIGURATION - QoS

Figure 9-8 - Network Configuration Page - Switch - QoS

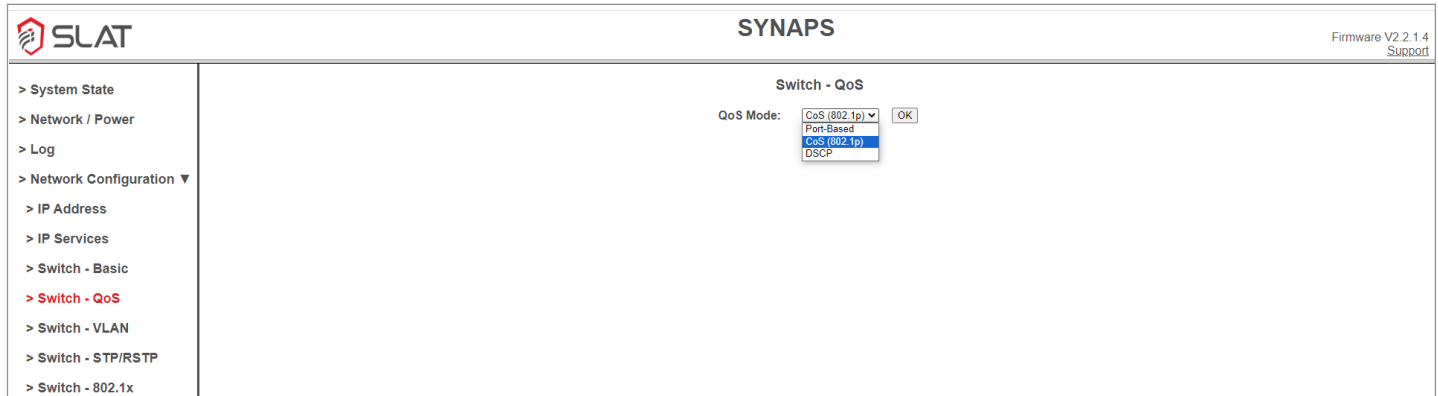

Quality of service (QoS) is the manipulation of traffic such that a network device, such as a router or switch, forwards it in a fashion consistent with the required behaviours of the applications generating that traffic. In other words, QoS enables network devices to differentiate between the traffic and apply different behaviour to it.

QoS can operate in the following modes:

- Port-Based
- CoS (802.1p)
- DSCP

Click on “OK” to the right of “QoS mode” to save the configuration.

### 9-9-1. Port-based QoS

The user can allocate priorities to the Ethernet ports via the “Port-based QoS” feature.

4 priority levels are defined:

- 1. Lowest
- 2. Normal
- 3. Medium
- 4. Highest

### 9-9-2. QoS - CoS (802.1p)

In CoS mode, the priority is coded in the frame at level 2 of the OSI model. The priority is inserted in the IEEE 802.1q frame header. The “priority” information is coded on 3 bits.

By default, frames with a priority of 6 or 7 will have a priority of 3 in the queue. Frames with a priority of 4 or 5 will have a priority of 2 in the queue, etc.

The priority coded in the header remains the same when it passes through the switch (priority in = priority out).

### 9-9-3. QoS - DSCP

In DSCP mode, the priority is coded in the frame at level 3 of the OSI model (DiffServ field in IPv4 or TC “Traffic Class” in IPv6). DiffServ and Traffic Class are coded on 6 bits.

By default, frames with a DiffServ of between 0 and 0xF will have a priority of 0 in the queue. Frames with a DiffServ of between 0x10 and 0x1F will have a priority of 1 in the queue, etc.

## 9-10 NETWORK CONFIGURATION PAGE – SWITCH CONFIGURATION - VLAN

Figure 9-9 - Network Configuration Page - Switch - VLAN

Port	Not Member	Untagged	Tagged	VLAN ID	PVID
1	<input type="radio"/>	<input checked="" type="radio"/>	<input type="radio"/>	0001	0001
2	<input type="radio"/>	<input checked="" type="radio"/>	<input type="radio"/>	0001	0001
3	<input type="radio"/>	<input checked="" type="radio"/>	<input type="radio"/>	0001	0001
4	<input type="radio"/>	<input checked="" type="radio"/>	<input type="radio"/>	0001	0001
5	<input type="radio"/>	<input checked="" type="radio"/>	<input type="radio"/>	0001	0001
SYN	<input type="radio"/>	<input checked="" type="radio"/>	<input type="radio"/>	0001	0001

VLANs improve network management and optimise bandwidth. The VLAN groups together a set of computer devices in a logical, independent way. Several VLANs can co-exist simultaneously on the same network switch.

In the Switch - VLAN menu, the following actions are possible:

- Clicking on “OK” to the right of “802.1Q VLAN Mode” validates the activated or disabled selection.
  - ➔ Each port can be configured individually.
  - ➔ If the ports are configured in “Not Member” mode, they are isolated from the switch.
  - ➔ In “Untagged” (Access) mode, the VLAN ID can be configured with a value between 1 et 4094
- **N.B.** The product’s “SYN” port can also be configured in “Untagged” (Access) mode so that it is accessible on a specific VLAN.
- In “Tagged” (Trunk) mode, the port can be defined via the PVID and the VLAN in which the untagged incoming frames will be broadcast.
- Click on “OK” (at the bottom of the page) to validate the changes made.
- Pressing on “Reset” resets all the values to 0.

## 9-11 NETWORK CONFIGURATION PAGE – SWITCH CONFIGURATION - STP/RSTP

Figure 9-10 - Network Configuration Page – STP/RSTP

SLAT SYNAPS Firmware V2.2.1.4 Support

> System State  
> Network / Power  
> Log  
> Network Configuration ▾  
> IP Address  
> IP Services  
> Switch - Basic  
> Switch - QoS  
> Switch - VLAN  
> **Switch - STP/RSTP**  
> Switch - 802.1x

Switch - STP/RSTP  
Mode: Disabled

STP/RSTP function not available with 1 combo Ethernet switch (model 4P1C)

The Switch - STP/RSTP network configuration mode is not available with the products equipped with a single combo port. 2 possible modes:

- STP mode: provides a single path between any two end-points, eliminating and preventing loops in the network.
- RSTP mode: detects network topologies to provide faster convergence of the tree structure of the network.

## 9-12 NETWORK CONFIGURATION PAGE – CONFIGURATION SWITCH - 802.1X

Figure 9-11 - Network configuration page - Switch - 802.1x

SLAT SYNAPS Firmware V2.2.1.4 Support

> System State  
> Network / Power  
> Log  
> Network Configuration ▾  
> IP Address  
> IP Services  
> Switch - Basic  
> Switch - QoS  
> Switch - VLAN  
> Switch - STP/RSTP  
> **Switch - 802.1x**  
> CA Secure  
> Configuration  
> Disconnection

Switch - 802.1x  
802.1x authenticator:  Enabled  Disabled OK

Radius IP address: 192.168.1.102  
Authentication Port: 1812  
Shared key: [masked]  Show key  
Switch port number: 5  
Re-authentication Period: 120  Enable

Port	Mode
1	AUTO
2	AUTO
3	FORCE_AUTHORIZED
4	FORCE_AUTHORIZED
5	FORCE_AUTHORIZED

OK

To enable the 802.1x protocol, click Enabled and then click OK.

Then complete the following fields:

- The IP address of the Radius server.
- The software port number (default 1812).
- The authentication key shared by the Slat device and the Radius server.
- The uplink port on which the Radius server is accessible (port 5 or 6).
- The authentication frequency (in minutes, if enabled).
- The different port modes of the product: :
  - Auto: 802.1x
  - Force Authorized: Open
  - Force Unauthorized: Blocked
- Click OK to confirm.

9-13 NETWORK CONFIGURATION PAGE – CONFIGURATION CA SECURE

Figure 9-12 - Network configuration page - CA Secure



The Secure CA (Secure Analog Certificate) authenticates a unique analog signature for each PoE device. Secure CA can be enabled/disabled by checking/unchecking the CA Enabled box.



**CAUTION**

Always leave a port open for maintenance and local network connectivity. Do not enable CA Secure on the port where the computer is connected.

If a port is in "blocked" status you can reset it by clicking Initialize.

9-14 SYSTEM STATE PAGE - ACCESSING SYSTEM INFORMATION

Once connection with the product has been established, the “System State” page opens. Figure 9-13 and the paragraph below describe the information displayed on this page.

Figure 9-13 - System State Page

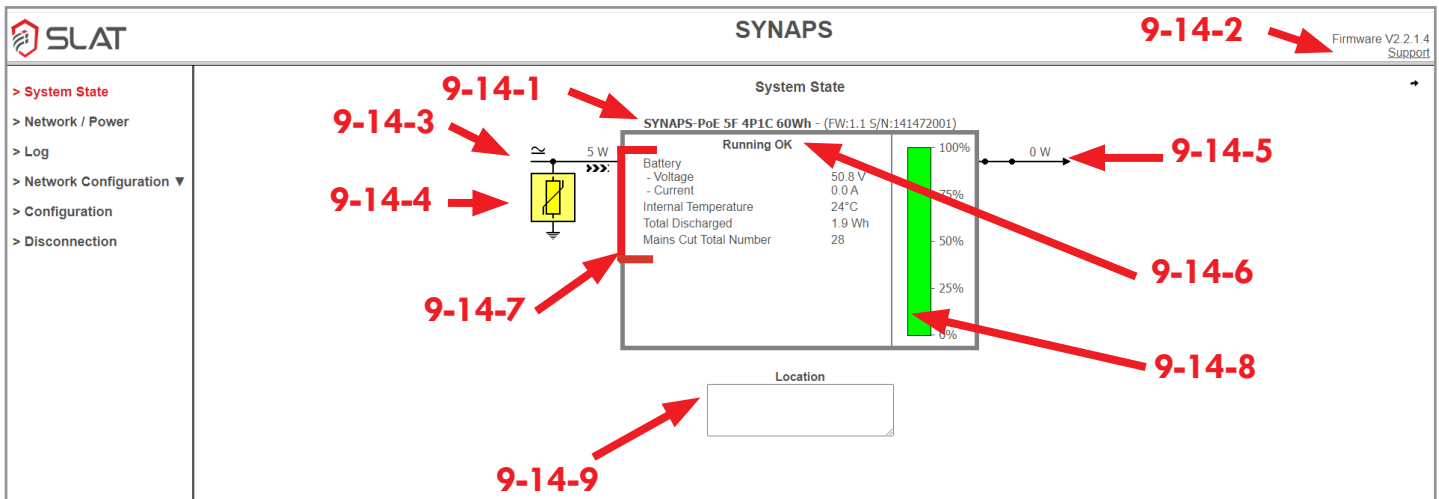

The “System State” page displays the operating status and all the physical values measured by the product. It is refreshed every 5 seconds. Click on the  icon to refresh the data manually.

### 9-14-1. Product description

- Reference and version
- Actual minimum capacity in watt-hours
- Power supply firmware and serial number

### 9-14-2. Communication firmware version and support

You can use the “Support” link to send an email to the SLAT after-sales service.

### 9-14-3. Mains input

Mains power is indicated by the pictogram on the left in Figure 9-13. If no mains power is present, a red cross is displayed over the pictogram. The value displayed indicates mains consumption in watts.

### 9-14-4. SURGE ARRESTER

- Surge arrester functioning correctly.

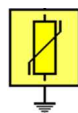

- Surge arrester malfunction.



**In case of malfunction, contact the SLAT hotline: +33 4 78 66 63 70**

### 9-14-5. Output

When the switch is closed, the application is powered by the product. If the switch is open, the backup is reaching the end of its autonomy: disconnection and interruption of the power supply are imminent. The value indicates the total power supplied to the application in watts.

### 9-14-6. Product operating status

The text indicates whether the product is operating correctly or whether there is a product fault.

The product operating mode is indicated by the frame colour:

- Operating on mains grey frame
- Operating on backup orange frame
- Eco or stealth mode green frame

### 9-14-7. Operation-related data

- Battery voltage in volts.
- Bbattery current in amps.
- Internal temperature of the SYNAPS-PoE in °C.
- Total watt-hours drained from the SYNAPS-PoE backup since product factory inspection and commissioning.
- Total number of mains outages

### 9-14-8. Charge gauge

The gauge shows the charge status of the backup. The backup must be fully charged once before the gauge will display an accurate reading.

### 9-14-9. Location

The location defines the place where the product is installed. This information can be entered in the “CONFIGURATION” page (see chapter 9-4, page 18).

## 9-15 LOG PAGE

Figure 9-14 - Log page

The screenshot shows the SLAT SYNAPS web interface. The top left has the SLAT logo, and the top right shows 'SYNAPS' and 'Firmware V2.2.1.4 Support'. The left-hand menu is expanded to 'Log'. The main content area is titled 'Log' and contains a list of events:

```

00:00:00 0D - DC Output Configuration: 24V
00:00:09 0D - P1: 100BASE-TX
01:02:13 0D - P1: PoE Active
01:02:14 0D - P1: PoE Standby
02:35:45 0D - P1: No Link
02:35:46 0D - Link Fault
03:08:30 0D - Mains Fault
03:08:30 0D - Backup Mode
00:00:00 0D - System Start
00:00:00 0D - DC Output Configuration: 24V
00:00:09 0D - P1: 100BASE-TX
00:53:00 0D - P1: No Link
00:53:01 0D - Mains Fault
00:53:01 0D - Link Fault
00:53:01 0D - Backup Mode
  
```

Below the list are four checked checkboxes:  Power,  Network,  Configuration, and  Miscellaneous. A [Download as text](#) link is also present.

To access the event log, click on the “Log” heading in the left-hand menu. This page displays the event history. It can be filtered in four categories: power, network, configuration and miscellaneous. The history can contain up to 100 events, the oldest being deleted automatically. The filtered event list can be downloaded in text form by clicking on the link.

### 9-15-1. Timestamp

If the date and time are available via the NTP (see “9-7-2. NTP configuration”, page 22”), events are timestamped in the following format: **hours : minutes : seconds day/month/year Event**

E.g.,



```

00:00:00 01/09/2024 - DC Output Configuration: 24V
00:00:09 01/09/2024 - P1: 100BASE-TX
00:53:00 01/09/2024 - P1: No Link
00:53:01 01/09/2024 - Mains Fault
00:53:01 01/09/2024 - Link Fault
  
```

Otherwise, the time elapsed since the last start-up is used pending the availability of NTP data. In this case, events are in the following format: **hours : minutes : seconds number of days J Event**

E.g.,



```

00:00:00 0D - DC Output Configuration: 24V
00:00:09 0D - P1: 100BASE-TX
00:53:00 0D - P1: No Link
00:53:01 0D - Mains Fault
00:53:01 0D - Link Fault
  
```

## 9-15-2. Events list

Tableau 9-2 - Events related to the power converter

TYPE OF EVENT	SEVERITY LEVEL	COMMENT
End of backup	0	Backup at the end of autonomy. Imminent shutdown.
Short circuit	2	Short circuit on output.
Charger fault	2	Charger malfunction: the product must be changed.
Converter fault	2	Output converter malfunction: the product must be changed.
Battery fault	2	Battery malfunction: the product must be changed.
P* - PoE fault	3	PoE fault on port P* (overload, short circuit).
Backup mode	4	The product is operating in Backup out of Green mode.
Overload	4	Output consumption > 100% of the nominal value (current limitation to limit the output power).
Mains fault	4	No mains.
Temperature fault	4	Internal temperature too high.
High consumption	5	Output consumption > 95% of the nominal value.
Normal mode	6	Normal operation on mains.
Green mode	6	Mains present, the product is in stealth mode or energy-saving mode (ECO).
Consumption OK	6	Normal output consumption.
Stealth request	6	Receipt of an external instruction to operate in stealth mode.
Stop stealth request	6	Receipt of an external instruction to stop stealth mode.
Mains OK	6	The mains power supply is present.
Temperature OK	6	Internal temperature OK.
Charger OK	6	The charger is operating correctly.
Converter OK	6	The output converter is operating correctly.
Battery OK	6	Battery OK.
P* - PoE Halted	6	PoE port P* is actually stopped.
P* - PoE Active	6	PoE is active: energy is supplied on port P*.
P* - PoE Standby	6	PoE port P* is ready to provide power.
P* - PoE On (802.3)	6	PoE port operation command in accordance with the 802.3af/at/bt standards.
P* - PoE On (55 V)	6	PoE operation command in 55 V forced mode.
P** - PoE On (24 V)	6	PoE operation command in 24 V forced mode.
P** - PoE On (12 V)	6	PoE operation command in 24 V forced mode.
DC output - Restart	6	DC output restart command.
P* - PoE Restart	6	Port P* PoE restart command (stop for 8 seconds).

P\* -&gt; Identification of the port (Port 1 to Port 6)

P\*\* -&gt; Identification of the port (Ports 5 et 6)

TABLEAU 9-3 - Events relating to the network

TYPE OF EVENT	SEVERITY LEVEL	COMMENT
Link fault	4	Event activated when a port is disconnected or an Ethernet link is lost. The event is active until it is acknowledged (See "Tableau 10-3 - Details of the systemState variable", page 36: Bit 26 - Ethernet failure).
Website access protection	4	More than 3 successive unsuccessful attempts to access the website
Link fault acknowledgement	6	Acknowledgement of the link fault event
Px - No link	6	No Ethernet link for port Px
Px - 10BASE-T	6	10 Mbps copper Ethernet link for port Px
Px - 100BASE-TX	6	100 Mbps copper Ethernet link for port Px
Px* - 1000BASE-T	6	1000 Mbps copper Ethernet link for port Px
Px* - 10BASE-F	6	10 Mbps optical fibre Ethernet link for port Px
Px* - 100BASE-FX	6	100 Mbps optical fibre Ethernet link for port Px
Px* - 1000BASE-X	6	1000 Mbps optical fibre Ethernet link for port Px

Px -&gt; Identification of the port (P1 to P5)

Px\* -&gt; identification of port P5/P6

Tableau 9-4 - Events related to configuration

TYPE OF EVENT	SEVERITY LEVEL	COMMENT
Configuration reset	5	Restores factory configuration (see 9-16, page 33).
Output configuration: xxV	5	The DC output is configured in xxV (xx: DC output voltage: 12 V or 24 V)
Configuration changed	6	Event generated 2 minutes after the last product configuration change.

Tableau 9-5 - Miscellaneous events

TYPE OF EVENT	SEVERITY LEVEL	COMMENT
Surge arrester fault	3	Faulty surge arrester
Open cabinet	4	The customer access door is open (with opening detection option)
System start	5	SYNAPS-PoE start-up
Closed cabinet	6	The customer access door is closed (with opening detection option)
Surge arrester OK	6	The surge arrester is OK
On-Off input = 0	6	On-Off input set to = 0
On-Off input = 1	6	On-Off input open
On-Off output = 0	6	On-Off output at 0
On-Off output = 1	6	On-Off output at 1

## 9-16 RESTORING THE FACTORY SETTINGS

To return to the original factory settings, perform a factory configuration reset by pressing the reset button for 10 seconds (L Figure 6-3, page 9).

Figure 9-15 - Reset

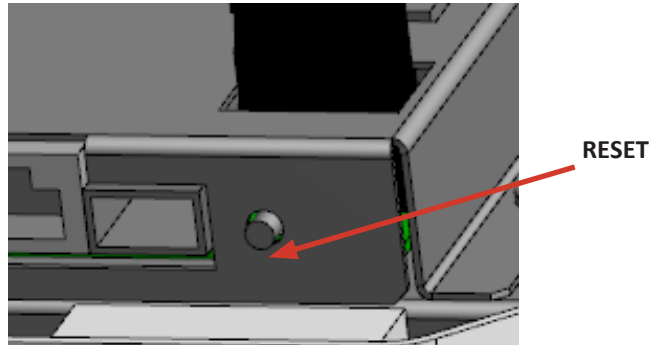

The SYNAPS-PoE restarts.

The PoE LEDs (yellow) at the top left of the RJ45 ports all light up for approximately 5 seconds then switch off before returning to normal functioning.

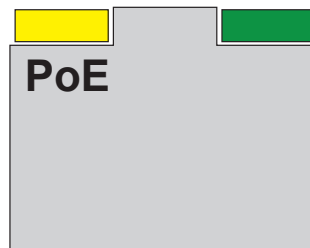

The SYNAPS-PoE is reset.



### IMPORTANT REMARK!

To perform the factory configuration reset, the product must be connected to the mains, or it will be switched off.

## 9-17 SHUTTING DOWN THE PRODUCT

To shut down the product:

- ➔ Switch off the mains power supply.
- ➔ Open the cabinet door.
- ➔ Disconnect all the Ethernet ports.

## 10 OPERATION

### 10-1 REMOTE REPORT - COMMUNICATION

When using the product, it is possible to communicate with it remotely using the built-in communication system. The Ethernet connection makes it possible to:

- retrieve information remotely.
- have more details about the types of faults.
- communicate analogue values (user voltages and currents, remaining backup percentage, internal temperature, autonomy).
- configure the power supply.

The product communicates its information on the Ethernet connection via the HTTP/HTTPS or BACnet SNMP application protocols. The information and explanations on how to configure the product are described in the chapter entitled “9 Commissioning”, page 17. The following sections describe the information available via the different protocols.

### 10-2 HTTP/HTTPS PROTOCOL

The HTTP/HTTPS website provides product management and data processing-related information.

The chapter entitled “9 Commissioning”, page 17 describes the use of the HTTP/HTTPS website and the various data available.

To log onto the embedded website, use the selected login and password. Section 9-4, page 18 describes how to change the password.

### 10-3 SNMP PROTOCOL

2 MIBs are accessible over SNMP:

- The MIB-2, defined by the RFC1213 standard.
- The SLAT-NPS MIB is proprietary and specific to SLAT. It is common to the entire SYNAPS range. It can be downloaded from the embedded website (HTTP/HTTPS) on the “Network” page (see section 9-6, page 21).



#### IMPORTANT REMARK!

For the SNMP v1 and v2c, the Read Community is “public” and the Write Community is “private”.  
For the SNMP v3, the user and the password must be configured.

Tableau 10-1 - MIB-2 variables

MIB-2		
VARIABLE	SNMP NAME	DESCRIPTION
Model	sysDesc	SYNAPS-PoE reference and version
Identifier	sysName	SYNAPS-PoE identifier (accessible in write mode, up to 16 characters)
Location	sysLocation	SYNAPS-PoE location (accessible in write mode, up to 32 characters)

Tableau 10-2 - MIB SLAT variables

SLAT MIB		
VARIABLE	SNMP NAME	DESCRIPTION
Model	model	SYNAPS-PoE reference and version.
Capacity	capacity	Battery capacity: energy expressed in watt-hours.
Serial number	serialNumber	SYNAPS-PoE serial number.
System state	systemState	32-bit variable giving the state of the SYNAPS-PoE system. Each time a change is made, this variable is sent in the form of an SNMP trap (for details of the variable, see "System state" table)*.
Gauge	energyGauge	Gauge in percentage corresponding to the amount of energy available in the battery. A value of 100 corresponds to a fully charged battery.
Output voltage	outputVoltage	Output voltage: the value is expressed in tenths of a volt.
Output current	outputCurrent	Output current: the value is expressed in tenths of an ampere.
Output power	outputPower	Instantaneous power supplied by the SYNAPS-PoE: the value is expressed in watts.
Mains power	mainsPower	Instantaneous mains power input: the value is expressed in watts.
Temperature	temperature	SYNAPS-PoE internal temperature: the value is expressed in °C.
Total discharged energy	totalDischargedEnergy	Quantity of energy supplied by the SYNAPS-PoE battery since it was commissioned: the value is expressed in tenths of a watt-hour.
Total number of mains outages	mainsCutTotalNumber	Total number of power cuts since initial commissioning.
Output voltage adjustment	voutAdjust	Not applicable for SYNAPS PoE products.
Stealth mode threshold	stealthModeThreshold	Minimum battery charge level in percent for stealth mode. Accepted values: 25, 50, 75 or 100. The value 100 disables stealth mode.
Eco mode threshold	ecoModeThreshold	Minimum battery charge level in percent for eco mode. Accepted values: 50, 60, 70, 80 or 100. The value 100 disables eco mode.
Ethernet port X state:	ethernetPortX-State	32-bit variable giving the state of each Ethernet port, X representing the port number (for details of this variable, see table "Details of Ethernet port X").

\* In order to use SNMP traps, the IP addresses of the SNMP servers to which the traps should be sent must be entered into the HTTP/HTTPS website (see section entitled "9-5 Network/Power page – Configuring the ports and output voltage", page 19).

## 10-4 ACCESSIBLE DATA

The following data is accessible over SNMP.

Tableau 10-3 - Details of the *systemState* variable

BIT	NAME	DESCRIPTION
31	Auxiliary input	In read mode, auxiliary input state. If the bit is written to 1, the On-Off output switches to Off.
30	Auxiliary output	In read mode, On-Off output state. If the bit is written to 1, the On-Off output switches to On.
27 - 29	- Reserved -	
26	Ethernet fault	In read mode, if the bit is at 1, then one or more Ethernet links have been lost. The fault remains active even if the links are restored. To acknowledge the fault, set the bit to 1 in write mode, which then switches to 0 in read mode.
25	Halt stealth mode	Set bit to 1 in write mode to stop stealth mode. The bit remains at 0 in read mode.
24	Stealth mode start / status	In read mode, if the bit is at 1, then stealth mode is enabled. Set bit to 1 in write mode to start stealth mode.
23	PoE fault	If the bit is at 1, low PoE voltage or PoE communication failure.
22	Buck fault	If the bit is at 1, 12 V/24 V converter fault (low 12 V DC or 24 V DC output voltage + insignificant output current).
21	Low output voltage	If the bit is at 1, the 12 V DC or 24 V DC output voltage is low.
20	Output voltage	If the bit is at 0, output voltage set to 12 V DC. If the bit is at 1, output voltage set to 24 V DC.
19	Communication fault	Internal communication error if the bit is at 1. The values of the read data are not significant.
18	Initialisation fault	Initialisation of the internal communication in progress if the bit is at 1. The values of the read data are not significant.
17	Surge arrester state	If the bit is at 1, the surge arrester is OK. If the bit is at 0, the surge arrester is out of service.
16	Surge arrester present	The surge arrester is present. The bit is always equal to 1.
15	High battery current	If the bit is at 1, then the battery current is too high.
14	High battery voltage	If the bit is at 1, the product must be replaced: the battery voltage is too high.
13	End of autonomy	End of autonomy pre-alarm when the bit is at 1 (shutdown is imminent).
12	Battery fault	If the bit is at 1, the product must be replaced: the battery is faulty or has been removed.
11	Rectifier fault	If the bit is at 1, the product must be replaced: the charging system is faulty and the battery may not be charged.
10	Mains fault	If the bit is at 1, mains power is absent.
9	Output overload	If the bit is at 1, the output is overloaded.
8	Output short circuit	If the bit is at 1, the output is short-circuited.
7	High temperature	If the bit is at 1, the temperature in the product is too high.
6	Battery disconnection	If the bit is at 1, the battery is disconnected.
5	Stealth mode or eco mode	If the bit is at 1, stealth mode or eco mode is activated.
4	Intrusion detection	When the option is present, if the bit is at 1, box tampering or removal detection is enabled.
0 - 3	- Reserved -	-

Tableau 10-4 - Details of the *ethernetPortX-State* variables

BITS	NAME	DESCRIPTION
27 - 31	- RESERVED -	
26	Link type	(for combo port only) Designates the type of link on ports 5 and 6 (combo port) Fibre (=1), Copper (=0)
24-25	Ethernet State	Indicates the state of the Ethernet link: - 0b00: no link - 0b01: 10 Mbps link - 0b10: 100 Mbps link - 0b11: 1000 Mbps link
20 - 23	- RESERVED -	
18- 19	PoE Management	Indicates the state of the PoE control (read / write): - 0b00: - Reserved - - 0b01: PoE Off - 0b10: PoE On - 0b11: PoE Restart
16 - 17	PoE State	Indicates the state of the PoE port: - If the bit is at 0b00, the port is stopped. - If the bit is at 0b01, the port is in standby (802.3). - If the bit is at 0b10, the port is faulty. - If the bit is at 0b11, the port is activated.
0 - 15	PoE Power	PoE output power expressed in tenths of a watt

## 11 MAINTENANCE AND TROUBLESHOOTING

The product has been designed to function for a long period of time **without requiring maintenance**.



### IMPORTANT REMARK!

Any work on the product must only be performed by qualified personnel.

For additional technical assistance, contact the SLAT hotline: +33 4 78 66 63 70

For an RMA request (authorisation to return goods), refer to section "13-2 Product Returns", page 43.

Unexpected situations may arise during installation, commissioning or use. The table below may be consulted in case of problems. It contains a list of possible problems with their corresponding causes and solutions.

PROBLEM	COMMUNICATION FAULT	CAUSE	SOLUTION
The product does not start	No communication	The mains supply is not connected or is not present.	Check if the mains supply is correctly connected.
		The primary fuse is faulty or absent.	Replace the product.
There is no output voltage.	Output short circuit	Output overload or short-circuit.	Lower the output load until the current is less than the maximum output value.
The output voltage is less than the normal value.	Output overload	There is a slight overload on the output.	Lower the output load until the current is less than the maximum output value.
The product temperature is too high.	Temperature too high	Temperature is too high because the ambient temperature does not fulfil the specified conditions.	Cool the installation.
The product's IP address has been lost.	No communication	-	Perform a factory configuration reset
The administrator's password has been lost.	No communication	-	Perform a factory configuration reset.
A user's password has been lost.	No communication	-	Delete the user's account from the administrator's account.
No connection: The Link LED for ports 1 to 4 and the Uplink LEDs for port 5 are not lit.	No communication	Poor Ethernet connection.	Check the connection and use a suitable Ethernet cable
The Link or Uplink LEDs are lit but there is no communication.	No communication	Configuration problem.	Ensure that the SYNAPS-PoE and computer configurations are compatible

## 12 TECHNICAL DATA

### 12-1 ELECTRICAL CHARACTERISTICS

#### 12-1-1. Mains input electrical characteristics

Tableau 12-1 - Mains input electrical characteristics

MAINS INPUT	
AC network voltage	175 - 265 VAC (99-264 VAC)
Frequency	45-65 Hz
Class	I
Inrush current	Limited by NTC
Neutral system	TT, TN, IT
Primary short-circuit protection	Slow-blow fuse on the live
Characteristics of the built-in fuse	2.5 A (slow-blow, internal)
Shock wave protection	Differential mode by varistor and filter
Primary current @ 175 V AC	1.3 A
Primary current @ 265 V AC	0.7 A
Surge arrester	Type 2 / 10 kA (version with 4 Ethernet ports +1 combo port) or 40 kA (version with 4 Ethernet ports +2 combo ports)
Circuit breaker to be provided upstream	Curve D (recommended rating 2 A)

#### 12-1-2. Output electrical characteristics

Tableau 12-2 - Continuous output electrical characteristics

POE OUTPUTS	
PoE ports	5 PoE / PoE+ / PoE 55 V ports, including 2 HiPoE ports
PoE/PoE+	IEEE 802.3af/at - 15.4 W / 30 W per port; alternative B
HiPoE	IEEE 802.3bt - 15.4 W / 30 W / 60 W / 90 W per port; power supply on 4 PoE pairs (4PPoE)
PoE 12 V	Continuous operation, 1 A* per port (only on ports 5 & 6)
PoE 24 V	Continuous operation, 1 A* per port (only on ports 5 & 6)
PoE 55 V	Continuous operation, 30 W* per port
* <b>Caution:</b> at startup, $I_{max} = 400$ mA	
USAGE OUTPUT	
DC output	1 usage output (12 V DC or 24 V DC)
Rated voltage $U_n$	12 V DC   24 V DC
Current limitation $I_n$ for $U > 50\%$ of $U_n$	7.2 A   4.4 A
Output voltage regulation	$\leq 1\%$
Available output power	60 W   96 W
LF residual ripple	$< 5$ mV effective at $I_n$
Static and dynamic regulation characteristics	$< 7\%$ of $U_n$ for cumulative variations of the mains and the load (from 10 to 90%)
Protection	electronic (no fuse)
Protection against output short-circuit	by cutting off the converter with cyclical restart
Protection against user output surges	deregulation or connection error, by cut-off with cyclical restart if output voltage $> U_n + 10\%$

## 12-2 FUNCTIONAL CHARACTERISTICS

The SYNAPS-PoE offers trouble-free video-protection on an intermittent network. It enables reliable, durable video-protection systems to be quickly deployed using the existing public lighting infrastructure.

PoE/PoE+/HiPoE ports and a user output (12 V DC or 24 V DC) continuously supply constant voltages (12 V DC or 24 V DC) to the equipment to be powered. They ensure 24/7 power supply and continuity of service for equipment in the event of a power outage.

The Ethernet connection is used to remotely retrieve information including the analogue values (user voltages and currents, autonomy, internal electronic temperature).

The HTTPS webserver makes it possible to configure the communication parameters amongst other things, and to choose the operating mode.

## 12-3 MECHANICAL CHARACTERISTICS

Figure 12-1 - Customer space



Tableau 12-3 - Mechanical specifications

MECHANICAL SPECIFICATIONS	
Cabinet	Polycarbonate
Protection rating	IP65
Impact resistance	IK10
Dimensions (cabinet)	L 300 x H 400 x D 150 mm
Overall dimensions	L 300 x H 432 x D 171 mm
Available customer space	1: L 107 x H 90 x D 115 mm 2: L 130 x H 90 x D 115 mm
Weight	6.3 kg
SCx	0.132
Installation	Wall-, pull box- or pole-mounted box.

## 12-4 ENVIRONMENTAL SPECIFICATIONS

Tableau 12-4 - Environmental specifications

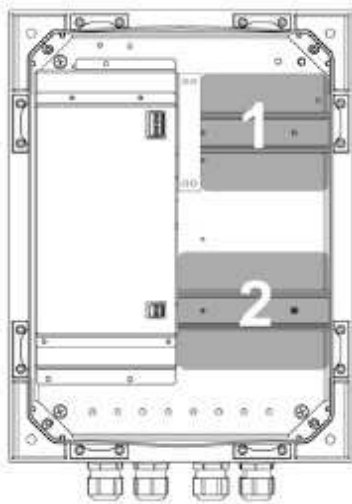
ENVIRONMENTAL SPECIFICATIONS	
Storage temperature	-20°C to +45°C
Operating temperature	-10°C to +50°C at rated power 120 W in backup and normal mode -10°C to +45°C at rated power 150 W in backup and normal mode
Hygrometry (relative humidity) in operation	0 to 100% condensing
Altitude	Above 2000 m, the maximum temperature is lowered by 5% every 1000 m.

## 12-5 STANDARD SPECIFICATIONS

### 12-5-1. IEEE standards

Tableau 12-5 - IEEE standards

IEEE STANDARDS	
IEEE 802.1D	Standard Spanning Tree
IEEE 802.1w	Rapid Spanning Tree (RSTP)
IEEE 802.1Q	VLAN
IEEE 802.3i	10BaseT
IEEE 802.3u	100BaseT(X) and 100BaseFX
IEEE 802.3ab	1000BaseT(X)
IEEE 802.3z	1000BaseX
IEEE 802.3x	Flow Control
IEEE 802.3af	PoE
IEEE 802.3at	PoE+
IEEE 802.3bt	HiPoE (type 1 to 4)
IEEE 802.3az	Energy Efficient Ethernet

### 12-5-2. Safety standards

Tableau 12-6 - Safety standards

SECTION	STANDARD NO.	TITLE / CONTENT
LVD Safety	EN IEC 62368-1 (2020)	Audio/video, information and communication technology equipment Part 1: Safety requirements
LVD Safety	EN IEC 62368-3 (2020)	Audio/video, information and communication technology equipment - Part 3: safety aspects for DC power transfer through communication cables and ports

**12-5-3. EMC standards****Tableau 12-7 - EMC standards**

SECTION	STANDARD NO.	TITLE / CONTENT
Immunity	EN IEC 61000-6-1 (2019)	Immunity standard for residential, commercial and light-industrial environments (generic standard)
Immunity	EN IEC 61000-6-2 (2019)	Immunity standard for industrial environments (generic standard)
Emission	EN IEC 61000-6-3 (2021)	Emission standard for residential, commercial and light industrial environments (generic standard).
Emission	EN IEC 61000-6-4 (2019)	Emission standard for industrial environments (generic standard).
Emission	EN IEC 61000-3-2 (2019) (class A)	Limits for harmonic current emissions (equipment input current $\leq$ 16 A per phase).
Emission	EN 55032 (2015) (class A)	Electromagnetic compatibility of multimedia equipment.

**12-5-4. Other standards****Tableau 12-8 - Other standards**

SECTION	STANDARD NO.	TITLE / CONTENT
Solar radiation	EN IEC 60068-2-5 (2018)	Environmental tests - Part 2-5: Tests – Test S: Simulated solar radiation at ground level and guidance for solar radiation testing and weathering.
Transport approval	UN 38.3	Standard UN 38.3 is the test certifying the fitness of the batteries for all types of transport and ensuring that they have passed all the selective tests required by the standard.

## 13 WARRANTY AND PRODUCT RETURNS

### 13-1 WARRANTY

The equipment is guaranteed for two years from when it leaves the factory. It is strictly limited to reimbursement or replacement (at our discretion and without compensation of any sort) of parts recognised as faulty by our services, following the return of the product to our workshops at the buyer's expense. The replacement or repair of equipment is possible only in our workshops. In order to allow our customers to benefit from the latest technical improvements, SLAT reserves the right to carry out any alterations considered appropriate.



#### IMPORTANT REMARK!

Mechanical opening of the covers of the sub-assemblies inside the product cancels **the manufacturer warranty!**

### 13-2 PRODUCT RETURNS

#### 13-2-1. Product under warranty

For the maintenance of your products under warranty, SLAT offer the best solution to facilitate your repairs and minimise lead times:

- ➔ Contact the Customer Service department using the form available on our web site [www.slat.com](http://www.slat.com), taking care to fill in all the required fields.
- ➔ The RMA form will be processed and sent back by the SLAT account manager.
- ➔ After receiving your RMA form, return two copies with your product(s), one **INSIDE** the package and the other on the **OUTSIDE** of the package for warehouse identification purposes, thereby guaranteeing traceability of your product.
- ➔ The repaired or replaced product(s) will be returned within a maximum of 15 business days.

#### 13-2-2. Product no longer under warranty

##### PRODUCT REPAIR BY SLAT

Contact Customer Services at [after.sales@slat.fr](mailto:after.sales@slat.fr) making sure that you provide all the following information:

- ➔ Last name / First name
- ➔ Company / Full address / Telephone / Email
- ➔ Exact model of the product (indicated on the product label) / SLAT reference (indicated on the product label, code number) / Serial No. / Quantity / Problems(s) encountered (describe the faults encountered with the product)

**THE FORM TO REQUEST THE RMA NUMBER IS ALSO AVAILABLE AT [WWW.SLAT.COM](http://WWW.SLAT.COM).**

The account manager will send the RMA form by email together with a quote according to the relevant product range.

After receiving your RMA form, return two copies with your product(s), one **INSIDE** the package and the other on the **OUTSIDE** of the package for warehouse identification purposes, thereby guaranteeing traceability of your product. The repairs will be performed only after the receipt of the accepted quote together with a repair order form. If the quote is rejected, please return it to [after.sales@slat.fr](mailto:after.sales@slat.fr) marked "refused" and specify whether the equipment should be destroyed or returned in its existing condition (in this case a charge of €150 will be invoiced for handling costs).

The repaired or replaced product(s) will be returned within a maximum of 15 business days. A new three-month warranty is attributed to the product in question.

**CONDITIONS: THE AUTHORISATION TO RETURN PRODUCTS IS ISSUED BY SLAT.  
AN RMA NUMBER IS ASSIGNED TO EACH PRODUCT TO BE RETURNED. EACH RMA NUMBER IS VALID FOR 30 DAYS.  
NO EQUIPMENT MAY BE RETURNED WITHOUT PRIOR ISSUANCE OF AN RMA NUMBER.**

**For additional technical assistance, contact the SLAT hotline: +33 4 78 66 63 70**





# SLAT

**SLAT SAS**  
7B rue Jean Elysée Dupuy  
69410 Champagne au Mont d'Or - France  
+33 4 78 66 63 60  
comm@slat.fr  
www.slat.com

**SLAT GmbH**  
Leitzstraße 45  
70469 Stuttgart – Germany  
+49 711 899 890 08  
info@slat-gmbh.de  
www.slat.com