



SLAT
for safer buildings



Catalog 2026

CONTACTS 

Sales department

 Sales Managers

 Sales Support

+33 478 66 63 63
comm@slat.fr

Technical Department

 Quality Technicians

+33 478 66 63 70
after.sales@slat.fr

WE SUPPORT YOU IN ALL YOUR PROJECTS... 

“Contact us” via www.slat.com

 Standards support

 R&D support

 Marketing support

 Press / Communication



www.slat.com

FIND UP-TO-DATE INFORMATION ANYTIME YOU NEED IT



www.slat.com website offers you 365 days a year, and 24/7 latest and precise information. Check out the latest news about emblematic uses of our products, the latest developments in our solutions, our participation in trade fairs and events, SLAT publications in the press and our involvement in the environment.

WITH MYSLAT, EVERYTHING IS JUST A CLICK AWAY

MySLAT opens a private space gathering all relations you have with SLAT. Order tracking, invoices, complete documentation on products you ordered, BIM models, softwares, and more. Everything about you is just there, no need to search anymore. Even better! Take advantage of the services offered to you: technical questions, after sales assistance, express order...
Things are now so simple!



CCTV

Urban counting

10111
00010
00111

City entrance cameras



Video surveillance



Parking management



Urban information

Energy automation management



Fluids Management Systems



Urban heating



Electronic signage



Emergency and Medical systems

Emergency supply for equipment in the operating theater



Nurse call



HV/LV substation



SLAT secures critical equipments and technical networks for buildings and cities.



SLAT CONTRIBUTES TO THE RELIABILITY OF YOUR FIRE PROTECTION EQUIPMENT



More than 300,000 fires ravage buildings in your country. 16,000 of these involved workplaces and public buildings.

In all, these fires claim around **30,000 victims a year**. Thanks to increasingly sophisticated fire detection and safety systems, these figures have been falling almost continuously for over ten years. However, the vigilance and commitment of professionals and all stakeholders must continue. We welcome the new measures published in France to protect historic monuments in the wake of the tragic fire at Notre-Dame Cathedral, and hope that they will serve as an inspiration to other countries.

All the more so as new risks are emerging with the electrification of our practices. In fact, the primary cause of fires is still electrical malfunction. It's worth remembering that **3 out of 4 businesses disappear after a fire disaster**.

To improve the reliability of fire detection and fire containment equipment, SLAT works with leading manufacturers in the sector. SLAT offers facility managers and emergency response teams reliable equipment and **the guarantee of faultless operation of their installations**.



SELECTION GUIDE

	AES		SONAES
Standard	EN 54-4		EN 54-4
	EN 12101-10		
	NF SSI		
Application	Fire security		PA/VA Systems
Voltage	24 V	48 V	24 V
Current	2 A	2 A	6 A
	3 A	3 A	12 A
	4 A	4 A	-
	6 A	6 A	-
	8 A	8 A	-
	12 A	12 A	-
	16 A	-	-
	24 A	-	-
Format	Box or Rack		Rack
Battery capacity	7 Ah	2,1 Ah	Compatible with batteries from 65 to 225 Ah
	12 Ah	12 Ah	
	17 Ah	17 Ah	
	24 Ah	24 Ah	
	40 Ah	40 Ah	
	65 Ah	65 Ah	
Page	8		14



AES



Emergency power supplies with batteries – Fire Safety

24 V DC • 48 V DC



Certified as per standard: EN 54-4/A2
“Fire detection and alarm systems”
Certified as per standard: EN 12 101-10
“Smoke and heat control systems”
VdS Approval
Certificates can be downloaded from www.slat.com



Communication by LED on the front panel • Dry Contact*

The AES emergency power supplies provide permanent and backup power for Fire Safety installations.

**This range exists also with RS485 serial link*



C24

322 x 248 x 126 mm



C38

289 x 350 x 189 mm



C48

425 x 345 x 120 mm



C85

408 x 408 x 224 mm



C180

505 x 610 x 430 mm



Rack F3U

483 x 132 x 110 mm



Rack

483 x 132 x 235 mm

Main functions





- ~ Monitors battery presence and impedance (aging).
- ~ The installation resumes as soon as the mains returns.
- ~ Protects the battery from temperature variations.

Benefits of the AES range

- ~ A wide range of products in terms of power and enclosures.
- ~ Batteries connections supplied with protected lugs.
- ~ Built-in lightning protection.
- ~ Alarm reports on dry contacts.
- ~ 6 fused outputs as a standard (C38, C85).
- ~ Space and DIN rail provided for transmission units (C38, C85).

AB = With Battery
 SB = Without Battery

MODEL	WEIGHT (kg)	SIZE W x H x D (mm)	CODE
AES 24V			
AESI 24V 2A C24 AB 7Ah	7.8	322 x 248 x 126	2240224007
AESI 24V 2A C24 AB 12Ah	11.0	322 x 248 x 126	2240224012
AESI 24V 3A C24 AB 7Ah	8.5	322 x 248 x 126	2240324007
AESI 24V 3A C24 AB 12Ah	11.0	322 x 248 x 126	2240324012
AESI 24V 3A C38 AB 24Ah	25.0	289 x 350 x 189	2240338024
AES 24V 4A C24 AB 12AH	10.0	322 x 248 x 126	2040424012
AES 24V 4A C38 AB 17AH	18.0	289 x 350 x 189	2040438017
AES 24V 4A C38 AB 24AH	25.0	289 x 350 x 189	2040438024
AES 24V 4A F3U	3.0	483 x 132 x 110	2040430000
AES 24V 6A C38 AB 17AH	18.0	289 x 350 x 189	2040638017
AES 24V 6A C38 AB 24AH	25.0	289 x 350 x 189	2040638024
AES 24V 6A F3U	3.0	483 x 132 x 110	2040630000
AES 24V 8A C48 AB 12AH	17.0	425 x 345 x 120	2040848012
AES 24V 8A C85 AB 24AH	25.0	408 x 408 x 224	2040885024
AES 24V 8A C85 AB 40AH	40.0	408 x 408 x 224	2040885040
AES 24V 8A RACK	3.0	483 x 132 x 235	2040830000
AES 24V 12A C85 AB 40AH	40.0	408 x 408 x 224	2041285040
AES 24V 12A RACK	3.0	483 x 132 x 235	2041230000
AES 24V 16A C180 AB 65AH	68.0	505 x 610 x 430	2041618065
AES 24V 16A RACK	3.0	483 x 132 x 235	2041630000
AES 24V 24A C180 AB 65AH	68.0	505 x 610 x 430	2042418065
AES 24V 24A RACK	3.0	483 x 132 x 235	2042430000
AES 48V			
AES 48V 2A C24 AB 2,1AH	6.0	322 x 248 x 126	2080224002
AES 48V 2A C38 AB 12AH	21.0	289 x 350 x 189	2080238012
AES 48V 3A C38 AB 12AH	21.0	289 x 350 x 189	2080338012
AES 48V 3A F3U	3.0	483 x 132 x 110	2080330000
AES 48V 4A C48 AB 12AH	27.0	425 x 345 x 120	2080448012
AES 48V 4A C85 AB 17AH	50.0	408 x 408 x 224	2080485017
AES 48V 4A C85 AB 24AH	62.0	408 x 408 x 224	2080485024
AES 48V 6A C85 AB 24AH	50.0	408 x 408 x 224	2080685024
AES 48V 6A RACK	3.0	483 x 132 x 235	2080630000
AES 48V 8A C180 AB 40AH	80.0	505 x 610 x 430	2080818040
AES 48V 8A C180 AB 65AH	116.0	505 x 610 x 430	2080818065
AES 48V 8A RACK	3.0	483 x 132 x 235	2080830000
AES 48V 12A C180 AB 40AH	80.0	505 x 610 x 430	2081218040
AES 48V 12A C180 AB 65AH	116.0	505 x 610 x 430	2081218065
AES 48V 12A RACK	3.0	483 x 132 x 235	2081230000
AES 230V			
AES 230V C85 AB 24AH	33.0	408 x 408 x 224	2050085024

> Ratings								
	50 W	75 W	100 W	150 W	200 W	300 W	400 W	600 W
24 V DC	2 A	3 A	4 A	6 A	8 A	12 A	16 A	24 A
48 V DC	-	-	2 A	3 A	4 A	6 A	8 A	12 A
The currents values refer to the nominal current (I_n) at rated output power.								
> Standard-based specifications								
Safety	• EN IEC 62368-1 (2020) + A11 (2020)							
EMC - Interference Immunity	• EN 50130-4 (2011) + A1 (2014) • EN IEC 61000-6-1 (2019) • EN IEC 61000-6-2 (2019)							
EMC - Emission	• EN IEC 61000-3-2 (2019) • EN IEC 61000-6-3 (2021) • EN IEC 61000-6-4 (2019) • EN 55032 B class							
Industry-specific	• NFS 61940 • EN 54-4 / A2 • EN 12101-10							
Environmental	This product range meets the environmental requirements according to ISO 14001, RoHS and WEEE.    							
Certification		VdS 2344 - 2541 (all) VdS 2203 - 2593 - 2824 - 2882 (50-75 W)						
> Environmental specifications								
Hygrometry	During storage: relative humidity 10% to 95% (non-condensing) During operation: relative humidity 20% to 95% (non-condensing)							
Storage temperature	-25 to +85°C							
Operating temperature	Power	50 W - 75 W			100 W - 600 W			
	at 75% of load	-5°C to +50°C			-5°C to +50°C			
	at 100% of load	-5°C to +50°C			-5°C to +40°C			
Maximum operating height	Above 2,000 m, the maximum temperature decreases 5% every 1,000 m							
MTBF	200,000 hours at 25°C (ext. environment) and 75% of load at nominal mains voltage							
> Input characteristics								
Voltage	50 W - 75 W				100 W - 600 W			
	99 to 264 V AC single-phase				195.5 to 264 V AC single-phase			
Frequency	45 to 65 Hz							
Mains Type	TT - TN - IT							
Inrush current	Bipolar Curve C between 2 and 10 A				limited by NTC			
Upstream circuit breaker to be provided	D curve							
Class	Class I							
Primary current @ 195V	50 W	75 W	100 W	150 W	200 W	300 W	400 W	600 W
	0.4 A	0.5 A	0.75 A	1 A	1.5 A	2 A	3 A	4 A
Efficiency	50 W - 75 W		100 W - 150 W		200 W - 300 W		400 W - 600 W	
η @ 20% load	81.3%		75%		84%		85%	
η @ nominal load	90.1%		84%		90%		91%	
> Output characteristics								
Nominal voltage	24 V DC				48 V DC			
Float voltage (U_n) adjusted to half load and 25°C	27.2 V +/-0.5%				54.4 V +/-0.5%			
Current limitation charger	I_n							

> Reliability of the output voltage		
Protection against external interferences	<ul style="list-style-type: none"> - Resistance against all types of external interferences: <ul style="list-style-type: none"> • Overvoltage occurring in the power supply (lightning, industrial overvoltage, insulation faults on neutral conductor impedance earthing) • Short circuit at the primary circuit due to a delayed fuse on the phase conductor • Differential mode shock waves by varistor and fuse. • Battery polarity reversal. • Overvoltages on the secondary circuit. • Overcurrents and short-circuits on the secondary circuit. • The short-circuits inside the product, protected by primary fuse. • High ambient temperatures (outside the specified range). 	
Management of charger current limitation	<ul style="list-style-type: none"> - Output current limitation allows a charge cycle to be started with a empty battery. • Fully protects the product from short-circuits on the installation. • Protection selectivity is ensured by fuses on each load output and the battery fuse. 	
High performance filtering and regulation	<ul style="list-style-type: none"> - Particular efficient output voltage regulation <ul style="list-style-type: none"> • Static regulation < 0.5% of U_n. • Dynamic regulation < 5% of U_n for cumulative variations of the mains and the load (from 10% to 90%). - Enhanced filtering that eliminates all interference and reduces the ripple on the V DC output. Battery capacity preserved and the guarantee of optimum system operation. <ul style="list-style-type: none"> • LF rms ripple < 0.2% of U_n. • HF ripple (20 MHz-50 Ω) < 4 % of U_n. 	
> For the control and management of the emergency power source		
System control	<ul style="list-style-type: none"> - Monitoring of: <ul style="list-style-type: none"> • The status of Mains, battery and load fuses. • Battery presence or absence and its impedance. • Temperature inside the cabinet (200 W to 600 W). • Battery voltage and its operating status. • Mains voltage inside correct operating range. 	
Battery charge management	<ul style="list-style-type: none"> - This function is essential for reaching the design life and to ensure optimum operation of the battery. <ul style="list-style-type: none"> • The charge voltages are factory set for «sealed» recombination-type lead acid batteries. • They are consistent with the battery manufacturer's recommendations. • The charger features battery charge current limitation. • The supply of power to the load takes priority over the battery charge. 	
Battery backup	<ul style="list-style-type: none"> - Automatic disconnection of the load at end of discharge to preserve its future capacity. <ul style="list-style-type: none"> • Prevents deep discharge that can permanently downgrade performance, Cut-off threshold 1.8 V/cell (+/-0.5%). • An alarm is sent before disconnection (Pre-cut alarm threshold 1.85 V/cell (+/-0.5%). • The charger integrates a limitation of the battery charging current. This allows your application to take full advantage of the battery's capacity. 	
> Table of charger internal consumption during autonomy		
	24 V DC	48 V DC
50 W - 75 W	39 mA	-
100 W - 150 W	75 mA	85 mA
200 W - 300 W	44 mA	37 mA
400 W - 600 W	106 mA	73 mA

> For optimal communication



50 W - 75 W



100 W - 600 W

Display and remote reporting of the information

- **Mains fault (normal source): signaled locally by an orange LED.**
 - If the mains is not present or < 195 V.
 - If the mains fuse is blown or not present, or if product is out of order.
 - Remote reporting by dry contact with delay (failsafe).

- **Battery fault (safety supply): signaled by an orange LED.**
 - Remote reporting by dry contact with delay (failsafe).

- **If battery is not present:** The battery is tested in the following manner:
 - Every 30 seconds for the first 20 minutes after commissioning:
 - Every 15 minutes after the first 20 minutes, if a fault is detected, the test is conducted every 30 seconds, and continues up to 20 minutes after the fault disappears.

- **If the internal impedance is too high** (test every 4 hours maximum on a charged battery): signaled by a green LED

- **The impedance limit values are:**

	24 V DC	48 V DC
50 W - 75 W	650 mΩ +/-15%	-
100 W - 150 W	410 mΩ +/-10%	1.65 Ω +/-10%
200 W - 300 W	164 mΩ +/-10%	656 mΩ +/-10%
400 W - 600 W	82 mΩ +/-10%	328 mΩ +/-10%

- **If battery voltage < 1.8 V/ cell +/-3%.**

- **Output 1 voltage presence (replacement normal source):** Voltage presence on this output is indicated by a green LED.

- **Output 2 voltage presence (replacement normal source):**
 - Voltage presence on this output is indicated by a green LED.
 - Remote reporting by dry contact with delay (failsafe) of the absence of one of the 2 load outputs.

- **AES operates when the 2 green LEDs, corresponding to the load outputs, are illuminated.** If voltage is not present, the LEDs are off.

- **Temperature compensation:** A battery voltage compensation system maintains the charge characteristics within the limits specified by the battery manufacturer across the entire operational temperature range.

- **Battery current limitation (50 W-75 W):** 2 microswitches (position 25%, 50%, 75% of rated current) are used to select the battery charging current according to the battery capacity. Battery manufacturers recommend to maintain charging current within 0.1 to 0.3 C. The product is delivered with the jumper in the '75' position.

- **Battery current limitation (100 W-600 W):** A configuration jumper on the daughterboard (position 25%, 50%, 75% of the rated current) allows to adapt the battery charging current to its capacity. The product is delivered with the jumper in the '75' position.

- **Battery low voltage outage:** The outage threshold is 1.8 V/ cell +/- 3%. The element causing the outage will be in the + position.

Communication AES

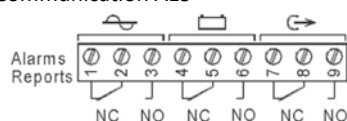

3 dry contacts with delay (failsafe) 1 A @ 24 V DC / 0.3 A @ 125 V AC

Communication AESRS

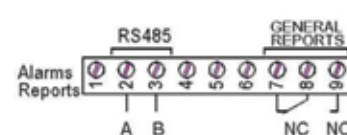

- The 3 faults (mains, battery, charger) and the information of opening the cover or removal from the wall are grouped on a single dry contact (failsafe).
- Dry contacts: 1 A @ 24 V DC, 0.3 A @ 125 V AC.
- An RS485 connection (Modbus) gives the above information in detail and communicates the analog values (voltages and load current, battery, rectifier, battery temperature).
- The power supply is addressed by two microswitches (4 possible addresses).

> Connections specifications					
Screw terminal	50 W - 75 W	100 W - 150 W	200 W - 300 W	400 W - 600 W	
Mains	2.5 mm ² *	2.5 mm ²	2.5 mm ²	2.5 mm ²	
Batteries	2.5 mm ² *	6 mm ²	6 mm ²	10 mm ²	
Load (2, 6 or 10 outputs)	2.5 mm ² *	6 mm ²	6 mm ²	10 mm ²	
Alarm reports	1.5 mm ² *	1.5 mm ² *	1.5 mm ² *	1.5 mm ² *	
*Unpluggable connectors - Dry contacts, 1 A @ 24 V DC, 0.5 A @ 120 V DC.					
> Cabinet and rack characteristics					
	Size W x H x D (mm)	Weight (kg)	IP	Base	Cover
C24	322 x 248 x 126	6 - 10	IP30	Metal, RAL 9006	ABS RAL 9003
C38*	289 x 350 x 189	21 - 25	IP31	Metal, RAL 7035	Metal, RAL 7035
C85*	408 x 408 x 224	25 - 50	IP31	Metal, RAL 7035	Metal, RAL 7035
C180	505 x 610 x 430	68 - 116	IP31	Metal, RAL 7035	Metal, RAL 7035
Rack	483 x 132 x 235	3	IP30	Metal, RAL 7035	Metal, RAL 7035
Rack F3U	482 x 132 x 110	3	IP30	Metal, RAL 7035	Metal, RAL 7035
*The following is installed in the C38 and C85 housings (24 V versions): - a card with 5 fuse outputs (6 instead of 2 outputs are available) - a DIN rail for integration of the user's equipment. The following can be installed additionally in the C38 and C85 housings (24 V versions): - an additional card with 5 fuse outputs (10 instead of 6 outputs are available).					
> Battery capacity according to cabinet					
Cabinet	Type	24 V DC	48 V DC		
C24	Wall-mounted	7 Ah, 12 Ah	2.1 Ah		
C38	Wall-mounted & Floor-mounted	17 Ah, 24 Ah	7 Ah, 12 Ah		
C85	Wall-mounted & Floor-mounted	24 Ah, 38 Ah	12 Ah, 17 Ah, 24 Ah		
C180	Floor-mounted	65 Ah, 80 Ah, 120 Ah, 130 Ah, 170 Ah	38 Ah, 65 Ah, 80 Ah		
Rack F3U	Rack	-	-		
Rack	Rack	-	-		

SLAT can change specifications on his products without prior notice.



Certified as per standard EN 54-4/A2

"Detection and fire alarm systems"
 Certificates can be downloaded from www.slat.com

Communication by LED on the front panel • Dry contact

SONaes battery chargers associated with a battery can be used to back up public address safety systems for evacuation of buildings.



Rack 2U - front view
483 x 89 x 399 mm



Rack 2U - back view
483 x 89 x 399 mm

Main functions

- ~ Alarm currents can be configured from 40 A to 150 A.
- ~ Checks the presence and the impedance of the battery.
- ~ Protects the battery from temperature variations and deep discharge.
- ~ Alarm reports via dry contacts and locally.

Benefits of the SONaes range

- ~ Up to 6 amplifier outputs 40 A and 3 independent fused auxiliary outputs.
- ~ All connectors are pluggable.
- ~ Fully protected product, with rear connectors.
- ~ Integrated lightning protection.

MODEL	WEIGHT (kg)	SIZE W x H x D (mm)	CODE
SONAES 24V			
SON 24V 6A MS 40 RACK	3.1 kg	483 x 89 x 355	4540633000
SON 24V 12A MS 150 RACK	5.4 kg	483 x 89 x 399	4541233000
FRONT TERMINAL BATTERY 24V			
BAT FRONT 24V 100Ah +CABLOT	75.0 Kg	1 tray	6540000100
BAT FRONT 24V 150Ah +CABLOT	110.0 Kg	1 tray	6540000150

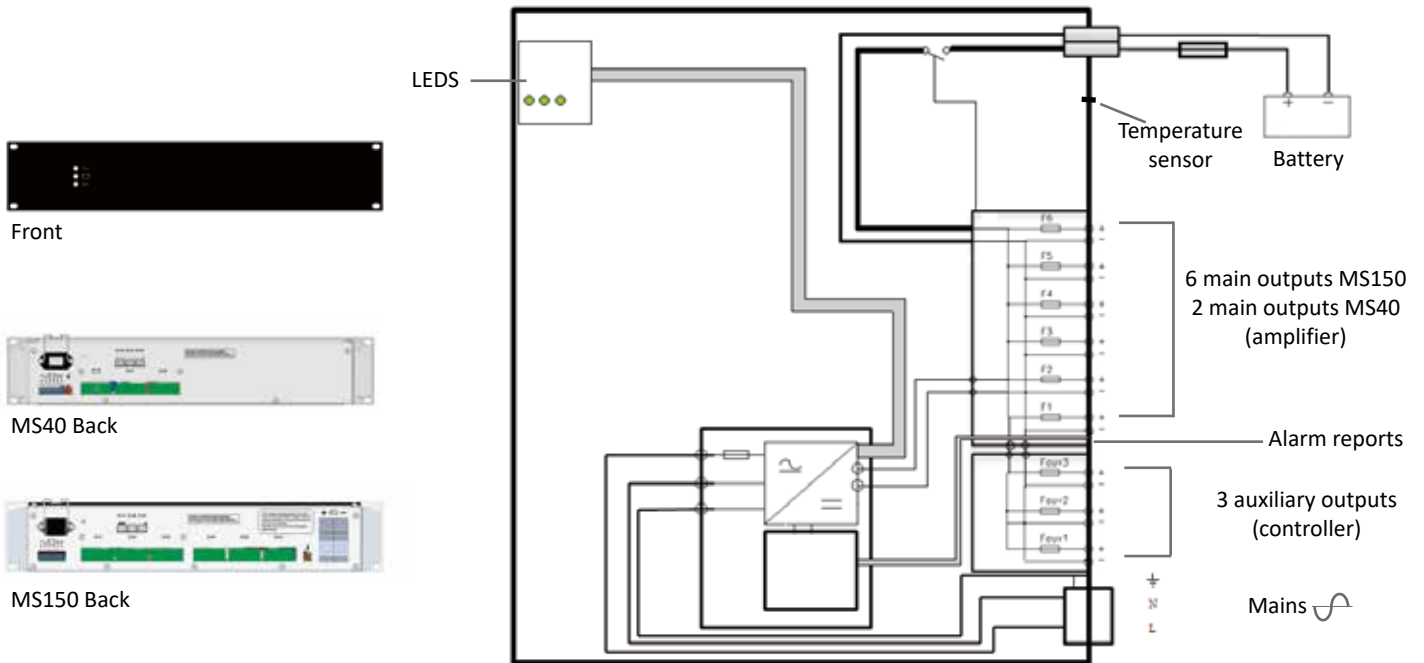

	SON 24V 6A MS40 RACK	SON 24V 12A MS150 RACK
> Standard-based specifications		
Safety	• EN 54-4 • EN 12101-10 classe A	
EMC - Immunity	• EN IEC 62368-1 (2020) + A11 (2020)	
EMC - Emission	• EN 50130-4 (2011) + A1 (2014) • EN IEC 61000-6-1 (2019) • EN IEC 61000-6-2 (2019)	
Trade	• EN IEC 61000-3-2 (2019) • EN IEC 61000-6-3 (2021) • EN 55032 B class	
Environment	This product range meets the environmental requirements of ISO 14001, RoHS and WEEE standards. 	
> N°CPR (CE)	1116-CPR-112	1116-CPR-089
> Environmental specifications		
Humidity	During storage: relative humidity 10% to 95% (non-condensing) In operation: relative humidity 20% to 95% (non-condensing).	
Storage temperature	-25 to +85°C	
Working temperature	-5 to + 45°C	
Altitude	Above 2,000 m, the temperature decreases by 5% every 1,000 m	
MTBF	200,000h with external ambient temperature of 25°C, nominal mains voltage, 48h full charging per year and for the rest of the time: 25% of load	
> Ratings		
Maximum current for all outputs	40 A	150 A
Number of amplifier outputs	2	6
Maximum power per amplifier output	20 A	40 A
Number of controller outputs	3	
Maximum power per controller output	5 A	

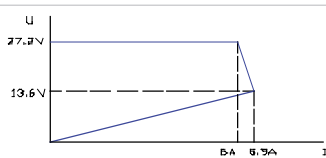
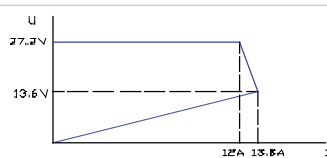
	SON 24V 6A MS40 RACK	SON 24V 12A MS150 RACK
> Mains		
Mains voltage	198 to 264 V AC	
Frequency	45 to 65 Hz	
Power at full load	190 W	380 W
Efficiency at full load	84%	87%
Efficiency at 20% of load	74%	82%
Neutral and earthing systems	TT, TN, IT	
Class	Class I	
> Output		
Floating voltage (U_n) set at half load and 25°C	27.2 V DC +/-0.5%	
Nominal output rectifier current	6 A	12 A
Current limitation - short circuit current		
Peak to peak HF residual voltage (20 MHz-50 Ω)	< 4% of floating voltage	
RMS LF residual voltage	< 0.2% of floating voltage	
Static and dynamic regulation characteristics	< 5% of floating for mains voltage and output load (from 10 to 90%)	
> Battery		
Cut-off threshold	21.6 V +/- 3%	
Internal impedance threshold of the battery fault	50 mΩ +/-10%	- 24 mΩ +/-10% if jumper in '50' position - 16 mΩ +/-10% if jumper in '75' position
Maximum current for all outputs drawn from the battery	40 A	*- 100 A if jumper in '50' position - 150 A if jumper in '75' position
Minimum battery capacity	24 Ah	*65 Ah if jumper is on '50' position 86 Ah if jumper is on '75' position
Maximum battery capacity	110 Ah	225 Ah
Battery voltage compensation	A system for the compensation of the battery output voltage maintains the charging characteristics within the battery manufacturer's specifications over the entire operating temperature range. If the sensor is broken or disconnected or has short circuit, the battery voltage is no longer compensated.	
Internal rectifier consumption	140 mA	430 mA
> Connections		
Mains	2.5 mm ² plug-in (IEC320) and lockable	
Main outputs	16 mm ² plug-in	
Auxiliary outputs	2.5 mm ² plug-in	
Battery output	16 mm ² plug-in	50 mm ² plug-in
Alarm outputs	1.5 mm ² plug-in	
Temperature sensor	1.5 mm ² plug-in	

* 2 current configurations are available depending on jumper position.

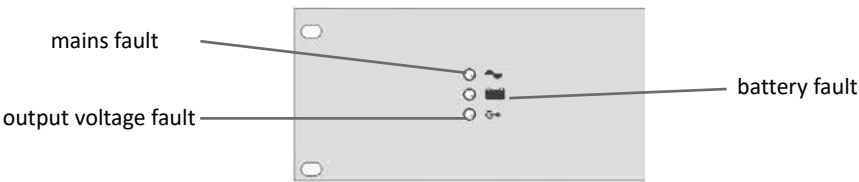
	SON 24V 6A MS40 RACK	SON 24V 12A MS150 RACK
> Protections		
Against unintentional battery reverse	<ul style="list-style-type: none"> - At start-up: the battery is not connected - During operation: the fuse F8 (5 x 20, rated:6.3 A, type T) on the power and control board blown 	<ul style="list-style-type: none"> - At start-up: the battery is not connected - During operation: the fuse F8 (5 x 20, rated:12.5A, type T) on the power and control board blown
Against battery wiring error	<ul style="list-style-type: none"> - If battery voltage > 30 V +/-3%, the battery is not connected - If battery voltage < 14 V +/-3%, the battery is not connected 	
Against output over-voltage	<ul style="list-style-type: none"> - Regulation problem: by switching off the power supply and restarting cyclically. The threshold is 28.8 V +/-3% - External: by transient voltage suppressor 	
> Fonctionnal characteristics		
Alarms and signalisations	 <p style="text-align: center;">Led indication: Green = Ok / Orange=Mains fault active</p>	
Mains	<p>Fault if:</p> <ul style="list-style-type: none"> - mains voltage threshold <185 V +/-5% as long as the charger has not started, <165 V +/-5% when the charger has started - no primary fuse or fuse has blown - power supply is broken - internal temperature is too high 	
Battery	<p>Fault if:</p> <ul style="list-style-type: none"> - no battery - high impedance on battery and its associated circuit - battery voltage < 23.5 V +/-3% mains present <p>Battery fault monitoring</p> <ul style="list-style-type: none"> - Detection of the presence/absence of the battery: 1 test every 30 seconds during the first 20 min and every 15 min after (in normal operation). As soon as a fault detection, the test is repeated every 30 seconds until no fault. - Measurement of the impedance of the battery and its associated circuit: 1 test every 4 hours the mains is present on the power supply and if the power supply has a current < rectifier current. 	
Output	<p>Fault: when one of the auxiliary or main outputs fails</p>	
Alarm reports	<p>Each alarm can be transmitted by dry contacts free of potential (C-NO-NC) allowing 1 A @ 24 V DC, 0.5 A @ 120 V AC</p>	
> Mechanical characteristics		
Dimensions	<p>Rack 19" (MS40): W 483 mm x H 88 mm (2U) x D 355 mm (with connectors) / 344 mm (without connectors) Rack 19" (MS150): W 483 mm x H 88 mm (2HE) x D 398 mm (with connectors) / 344 mm (without connectors)</p>	
Weight	3.1 kg	5.4 kg
IP (front side)	IP 30	

SLAT can change specifications on his products without prior notice.

ACCESS CONTROL AND VIDEO

WITH SLAT POWER SUPPLIES, YOUR ACCESS CONTROL REMAINS OPERATIONAL



Protecting people and property remains a major concern for all building managers. In fact, there were over 200,000 burglaries a year in a large country such as France, i.e. a burglary every 2 minutes. Damage to buildings represents twice this figure. And, it is estimated to represent only 11% of all acts of vandalism.

In the face of these threats, access control and intrusion protection equipment requires high-performance power supplies that meet **EN 50131-6 standards**.

By integrating **video protection** into **access and intrusion** control functions, new power and data transmission requirements have emerged.

SLAT provides you with **the most reliable solutions** in the shortest possible time. We also offer service continuity solutions for IP-based systems.



SELECTION GUIDE

	AXS2		AXS3		FIT'IN			SDC-M RS	SDC-M IP	SDC- PoE
Standard	EN 50131-6 grade 2		EN 50131-6 grade 3		-			-	-	-
DC output voltage	12 V	24 V	12 V	24 V	12 V	24 V	48 V	12 V / 24 V / 48 V	12 V / 24 V	55 V
Current / Power	2 A / 5 A / 10 A	1 A / 2.5 A / 5 A	4 A / 6 A	2 A / 3 A	6 A / 12 A / 24 A / 32 A	3 A / 6 A / 12 A / 24 A	3 A / 6 A / 12 A	30 W / 55 W	55 W	55 W
Number of terminal outputs	1 / 3* / 5*		2 / 4* / 6*		2			1 / 2	1	1
PoE/PoE+ ports	-		-		-			-	-	1
Ethernet ports	-		-		-			-	2	1
Format	DIN / card / box		Box		Card			DIN / Box	DIN / Box	DIN
Battery technology	Lead		Lead		Lead			Lithium	Lithium	Lithium
Battery capacity	7 Ah	1.2 Ah	7 Ah	7 Ah	Compatible with batteries up to 240 Ah	Compatible with batteries up to 180 Ah	Compatible with batteries up to 90 Ah	B	D	D
	12 Ah	7 Ah	12 Ah	12 Ah				D	G	G
	17 Ah	12 Ah	24 Ah	24 Ah				E		
	24 Ah	17 Ah	40 Ah					G		
	40 Ah	24 Ah								
Page	20		25		38			103	108	112

* with option



AXS2



Uninterruptible Power Supplies with battery - Intrusion / Access Control

12 V DC • 24 V DC



Complies with Standard: EN 50131 – 6 grade 2
“Alarm Systems, Intrusion and hold-up systems”

Communication by LED on the front panel • Dry Contact

The AXS2 Uninterruptible Power Supplies with battery provide permanent and backup power for Intrusion and Access Control installations.



DIN
105 x 90 x 62 mm



CG2
125 x 177 x 68 mm



C7
243 x 195 x 96 mm



C24
322 x 248 x 126 mm



C35
367 x 352 x 108 mm



C38
289 x 350 x 189 mm

Main functions





- ~ Resists short-circuits on load outlets
- ~ Controls and reports operating status
- ~ Resumes as soon as the mains returns
- ~ Opening and tamper contacts (on models with casing).

Benefits of the AXS2 range

- ~ One independent fuse-protected load outlet
- ~ Optional: card with 3 feeders and 5 feeders
- ~ Dimensioned to operate 24/7 at rated power
- ~ Built-in lightning protection.

AB = With Battery
SB = Without Battery

MODEL	WEIGHT (kg)	SIZE W x H x D (mm)	CODE
AXS2 12V			
AXS2 12V 2A DIN	0.2 kg	105 x 90 x 62	2720220000
AXS2 12V 2A C7 SB	1.0 kg	243 x 195 x 96	2720207000
AXS2 12V 2A C7 AB 7AH	4.0 kg	243 x 195 x 96	2720207007
AXS2 12V 2A C24 SB	2.0 kg	322 x 248 x 126	2720224000
AXS2 12V 2A C24 AB 12 AH	6.0 kg	322 x 248 x 126	2720224012
AXS2 12V 5A DIN	0.2 kg	105 x 90 x 62	2720520000
AXS2 12V 5A C7 SB	1.0 kg	243 x 195 x 96	2720507000
AXS2 12V 5A C7 AB 7AH	4.0 kg	243 x 195 x 96	2720507007
AXS2 12V 5A C24 SB	2.0 kg	322 x 248 x 126	2720524000
AXS2 12V 5A C24 AB 12 AH	6.0 kg	322 x 248 x 126	2720524012
AXS2 12V 5A C24 AB 24 AH	12.0 kg	322 x 248 x 126	2720524024
AXS2 12V 5A C35 SB	2.7 kg	375 x 360 x 138	2720535000
AXS2 12V 5A C35 AB 7AH	7.5 kg	375 x 360 x 138	2720535007
AXS2 12V 5A C35 AB 17AH	9.2 kg	375 x 360 x 138	2720535017
AXS2 12V 5A C38 SB	5.0 kg	289 x 350 x 189	2720538000
AXS2 12V 5A C38 AB 40AH	20.0 kg	289 x 350 x 189	2720538040
AXS2 12V 10A CG2	1.0 kg	125 x 177 x 68	2721002000
AXS2 12V 10A C35 SB	3.1 kg	375 x 360 x 138	2721035000
AXS2 12V 10A C35 AB 17AH	8.5 kg	375 x 360 x 138	2721035017
AXS2 12V 10A C38 SB	5.0 kg	289 x 350 x 189	2721038000
AXS2 12V 10A C38 AB 24 AH	15.0 kg	289 x 350 x 189	2721038024
AXS2 12V 10A C38 AB 40 AH	20.0 kg	289 x 350 x 189	2721038040
AXS2 24V			
AXS2 24V 1A DIN	0.2 kg	105 x 90 x 62	2740120000
AXS2 24V 1A C7 SB	1.0 kg	243 x 195 x 96	2740107000
AXS2 24V 1A C7 AB 1,2AH	4.0 kg	243 x 195 x 96	2740107001
AXS2 24V 1A C24 SB	2.0 kg	322 x 248 x 126	2740124000
AXS2 24V 1A C24 AB 7 AH	8.0 kg	322 x 248 x 126	2740124007
AXS2 24V 2,5A DIN	0.2 kg	105 x 90 x 62	2740220000
AXS2 24V 2,5A C24 SB	2.0 kg	322 x 248 x 126	2740224000
AXS2 24V 2,5A C24 AB 7AH	8.0 kg	322 x 248 x 126	2740224007
AXS2 24V 2,5A C24 AB 12AH	10.0 kg	322 x 248 x 126	2740224012
AXS2 24V 2,5A C35 SB	2.7 kg	375 x 360 x 138	2740235000
AXS2 24V 2,5A C35 AB 7AH	7.9 kg	375 x 360 x 138	2740235007
AXS2 24V 2,5A C35 AB 17AH	14.0 kg	375 x 360 x 138	2740235017
AXS2 24V 2,5A C38 SB	5.0 kg	289 x 350 x 189	2740238000
AXS2 24V 2,5A C38 AB 24AH	25.0 kg	289 x 350 x 189	2740238024
AXS2 24V 5A CG2	1.0 kg	125 x 177 x 68	2740502000
AXS2 24V 5A C35 SB	3.1 kg	375 x 360 x 138	2740535000
AXS2 24V 5A C35 AB 17 AH	8.5 kg	375 x 360 x 138	2740535017
AXS2 24V 5A C38 SB	5.0 kg	289 x 350 x 189	2740538000
AXS2 24V 5A C38 AB 24AH	17.0 kg	289 x 350 x 189	2740538024

> Ratings			
	20 W	60 W	125 W
12 V DC	2 A	5 A	10 A
24 V DC	1 A	2.5 A	5 A
The currents (I_n) shown are at rated output power.			
> Standard-based specifications			
Safety	• EN IEC 62368-1 (2020) + A11 (2020)		
EMC - Immunity	• EN IEC 61000-6-1 (2019) • EN IEC 61000-6-2 (2019)		
EMC - Emission	• EN IEC 61000-6-3 (2021) • EN IEC 61000-6-4 (2019) • EN 55032 class B		
Trade	EN 50131 - 6 Grade 2 (models with casing: a switch with a wired contact loop detects when the cover is opened or the unit is removed from the wall)		
Environment	This product range meets the environmental requirements of ISO 14001, RoHS and WEEE standards.    		
> Environmental specifications			
Humidity	in operation: relative humidity 20% to 95% non-condensing		
Storage temperature	-25 °C to +85 °C		
Working temperature	75% of load	-10°C to +60°C	
	100% of load	-10°C to +55°C	
Altitude	Above 2,000 m, the maximum temperature decreases by 5% every 1,000 m		
MTBF	200,000 hours at 25°C for external atmosphere and 75% load		
> Input specifications			
Voltages	198 to 264 V AC single-phase		
Frequency	45 to 65 Hz		
Neutral system	TT - TN - IT		
Inrush current	limited by CTN		
Upstream circuit breaker recommended	Bipolar curve D		
Class	Class I		
	20 W	60 W	125 W
Primary current @ 198 V	0.17 A	0.45 A	1 A
> Output specifications			
Rated voltage	12 V DC	24 V DC	
Floating voltage (U_n) set at half-load and 25°C	13.6 V	27.2 V	
Current limitation	I_n		

> For reliable output voltage		
Protection against external attack	<ul style="list-style-type: none"> - Resistance to all types of external aggressions: <ul style="list-style-type: none"> • Overvoltages encountered on the mains network (lightning, industrial, isolation fault on impedance-earthed neutral system, etc.) • Short-circuit on the primary power supply by a slow-blow fuse on the phase. • Differential mode shock waves by varistor and fuse. • Battery polarity inversions. • Overcurrents and short-circuits at secondary. • Short-circuits inside the product, protected by primary fuse. 	
Charger current limitation control	<ul style="list-style-type: none"> - Output current limitation allows a charging cycle to be started with a discharged battery. <ul style="list-style-type: none"> • Protects the product completely from short-circuits on the installation. • The selectivity of the protective devices is guaranteed by the battery fuse. 	
High-performance regulation and filtering	<ul style="list-style-type: none"> - Particularly efficient output voltage regulation. <ul style="list-style-type: none"> • Dynamic regulation < 5% U_n for cumulative variations of the mains voltage and the load (from 10% to 90%). - Enhanced filtering which eliminates all interference and reduces the residual ripple on the DC output. Battery capacity preserved and a guarantee of optimum system operation. <ul style="list-style-type: none"> • LF rms ripple voltage < 0.2% U_n. • HF ripple voltage (20 MHz-50 Ω) < 4% U_n. <p><i>N.B.: the AXS2 range can work without a battery and be used connected directly to the mains.</i></p>	
> For emergency power source control		
System control	<ul style="list-style-type: none"> - Monitoring of: <ul style="list-style-type: none"> • The status of fuses, mains, battery. • Battery voltage. • Its operating status. 	
Battery charge management	<ul style="list-style-type: none"> - This function is essential for reaching the design life and to ensure optimum operation of the battery. <ul style="list-style-type: none"> • The load voltages are factory set for "sealed" recombination-type lead acid batteries. • They are consistent with the battery manufacturers' recommendations. 	
> For optimal communication		
Display and remote reporting of information (C7, C24, C38)	<ul style="list-style-type: none"> - Mains or rectifier fault - Low voltage battery fault 	
On motherboard	<p>A LED on the motherboard indicates the operational state before the cabinet is closed.</p> <p>Signals:</p> <ul style="list-style-type: none"> - All OK: green - Faults: orange 	
Communication	20 W - 60 W	125 W
	<p>Dry contacts (failsafe): 1 A @ 24 V DC, 0.3 A @ 125 V AC. There are a total of 3 dry contacts:</p> <ul style="list-style-type: none"> - mains or rectifier - battery voltage - cover opening and wall detachment are grouped on one tamper dry contact. 	<p>Dry contacts (failsafe): 1 A @ 24 V DC, 0.3 A @ 125 V AC. There are a total of 2 dry contacts:</p> <ul style="list-style-type: none"> - mains, rectifier, battery voltage are grouped on one dry contact. - cover opening and wall detachment are grouped on one tamper dry contact.

> Connection specifications				
Screw terminal	12 V DC 2 A/5 A - 24 V 1 A/2.5A		12 V DC 10 A - 24 V 5 A	
	0.2 to 2.5 mm ²		0.2 to 6 mm ²	
> Options				
Kit 5 fuse protected outputs (only for the C35 version)	<ul style="list-style-type: none"> - Board to be installed by the customer. - Secured by 4 clips. - Connectors with 2.5 mm² screw terminals. - 5 x 20 fuse, rating 4 A. - Up to 2 boards can be mounted. 			
> Mechanical characteristics				
Version	Size W X H X D (mm)	IP	Base	Cover
DIN	105 x 90 x 62	IP10	ABS	ABS
CG2	125 x 231 x 73	-	Metal	Protective grille
C7	243 x 195 x 96	IP30	Metal, RAL 9006	ABS RAL 9003
C24	322 x 248 x 126	IP30	Metal, RAL 9006	ABS RAL 9003
C35	376 x 360 x 138	IP31	Metal, RAL 9006	ABS
C38	289 x 350 x 189	IP31	Metal, RAL 7035	Metal, RAL 7035
> Types of battery cabinet				
Cabinet	Type	12 V DC		24 V DC
DIN	DIN rail	-		-
CG2	DIN rail	-		-
C7	Wall-mounted	7 Ah		1.2 Ah
C24	Wall-mounted	7 Ah, 12 Ah, 24 Ah (2 x 12 Ah)		7 Ah, 12 Ah
C35	Wall-mounted	7 Ah, 17 Ah		7 Ah, 17 Ah
C38	Wall-mounted & floor-mounted	17 Ah, 24 Ah, 38 Ah		17 Ah, 24 Ah
> C35 configuration		Space for customer equipment available (mm)		
1 battery 7 Ah		170 x 310 x 80		
1 battery 17 Ah		170 x 210 x 80		
2 batteries 7 Ah		170 x 210 x 80		
2 batteries 17 Ah		170 x 170 x 80		
1 battery 17 Ah + 2x 5 fuse protected outputs boards		140 x 170 x 80		

SLAT can change specifications on his products without prior notice.

AXS3



Emergency power supplies with battery - Intrusion / Access Control

12 V DC • 24 V DC



Certified as per Standard: EN 50131 – 6 grade 3

“Alarm Systems, Intrusion and hold-up systems” VdS Approval (12V models)

Certificates can be downloaded from www.slat.com



Communication by LED on the front panel • Dry Contact*

The AXS3 emergency power supplies with battery provide permanent and backup power for Intrusion / Access Control installations.

* This range is also available with RS485 serial link.



C24
322 x 248 x 126 mm



C38
289 x 350 x 189 mm



C85
408 x 408 x 224 mm

Main functions

- ~ Controls and reports operating status
- ~ Monitors battery presence and impedance (aging)
- ~ Protects the battery from temperature variations
- ~ Protects the battery at end of discharge
- ~ Opening and tamper contacts





AB = With Battery

SB = Without Battery

Benefits of the AXS3 range

- ~ Two independent fuse-protected load outlets
- ~ Optional: card with 3 feeders and 5 feeders
- ~ Dimensioned to operate 24/7 at rated power
- ~ Built-in lightning protection
- ~ Resists short-circuits on load outlets
- ~ Resumes as soon as the mains returns.

MODEL	WEIGHT (kg)	SIZE W x H x D (mm)	CODE
AXS3 12V			
AXS3 12V 4A C24 SB	2.0 kg	322 x 248 x 126	2620424000
AXS3 12V 4A C24 AB 7 AH	5.0 kg	322 x 248 x 126	2620424007
AXS3 12V 4A C24 AB 12 AH	6.0 kg	322 x 248 x 126	2620424012
AXS3 12V 4A C38 SB	5.0 kg	289 x 350 x 189	2620438000
AXS3 12V 4A C38 SB + 5 DEP	5.0 kg	289 x 350 x 189	2620438999
AXS3 12V 4A C38 AB 24AH	15.0 kg	289 x 350 x 189	2620438024
AXS3 12V 6A C24 SB	2.0 kg	322 x 248 x 126	2620624000
AXS3 12V 6A C24 AB 7Ah	5.0 kg	322 x 248 x 126	2620624007
AXS3 12V 6A C24 AB 12 AH	6.0 kg	322 x 248 x 126	2620624012
AXS3 12V 6A C38 SB	5.0 kg	289 x 350 x 189	2620638000
AXS3 12V 6A C38 SB + 5 DEP	5.0 kg	289 x 350 x 189	2620638999
AXS3 12V 6A C38 AB 24AH	15.0 kg	289 x 350 x 189	2620638024
AXS3 12V 6A C38 AB 40AH	20.0 kg	289 x 350 x 189	2620638040
AXS3 12V 6A C85 SB	8.0 kg	408 x 408 x 224	2620685000
AXS3 24V			
AXS3 24V 2A C24 SB	2.0 kg	322 x 248 x 126	2640224000
AXS3 24V 2A C24 AB 7 AH	8.0 kg	322 x 248 x 126	2640224007
AXS3 24V 2A C38 SB	5.0 kg	289 x 350 x 189	2640238000
AXS3 24V 2A C38 SB +5 DEP	5.0 kg	289 x 350 x 189	2640238999
AXS3 24V 2A C38 AB 24 AH	25.0 kg	289 x 350 x 189	2640238024
AXS3 24V 3A C24 SB	2.0 kg	322 x 248 x 126	2640324000
AXS3 24V 3A C24 AB 7 AH	8.0 kg	322 x 248 x 126	2640324007
AXS3 24V 3A C24 AB 12 AH	10.0 kg	322 x 248 x 126	2640324012
AXS3 24V 3A C38 SB	5.0 kg	289 x 350 x 189	2640338000
AXS3 24V 3A C38 SB +5 DEP	5.0 kg	289 x 350 x 189	2640338999
AXS3 24V 3A C38 AB 24 AH	25.0 kg	289 x 350 x 189	2640338024
AXS3 24V 3A C85 SB	8.0 kg	408 x 408 x 224	2640385000
OPTIONS			
OPTION KIT 3 DEPARTS FUSIBLES	-	-	9900080000
OPTION CARTE 5 DEPARTS FUSIBLES	-	-	9059050004

> Ratings		
	50 W	75 W
12 V DC	4 A	6 A
24 V DC	2 A	3 A
The currents (I_n) shown are at rated output power.		
> Standard-based specifications		
Safety	• EN IEC 62368-1 (2020) + A11 (2020)	
EMC - Immunity	• EN IEC 61000-6-1 (2019) • EN IEC 61000-6-2 (2019)	
EMC - Emission	• EN IEC 61000-6-3 (2021) • EN IEC 61000-6-4 (2019) • EN 55032 class B	
Trade	• EN 50131 - 6 grade 3	
Environment	This product range meets the environmental requirements of ISO 14001, RoHS and WEEE standards.    	
Certification		VdS 2115
> Environmental specifications		
Humidity	while working: relative humidity 20% to 95% (non-condensing)	
Storage temperature	-25°C to +85°C	
Working temperature	Power	50 W - 75 W
	75% of load	-10°C to +60°C
	100% of load	-10°C to +55°C
Altitude	Above 2,000 m, the temperature decreases by 5% every 1,000 m	
MTBF	200,000 hours at 25°C for external atmosphere and 75% load	
> Input specifications		
Voltage	99 to 264 V AC single phase	
Frequency	45 to 65 Hz	
Neutral system	TT - TN - IT	
Switch-on current	limited by CTN	
Upstream circuit breaker required	Bipolar curve D	
Class	Class I	
	50 W	75 W
Primary current @ 195 V	0.51 A (12 V) - 0.52 A (24 V)	0.76 A (12 V) - 0.78 A (24 V)
Primary current @ 99 V	1 A (12 V) - 0.98 A (24 V)	1.63 A (12 V) - 1.5 A (24 V)
Efficiency	50 W	75 W
At 20% load	85%	85%
At rated load	88%	90%
> Output specifications		
Rated voltage	12 V DC - 24 V DC	12 V DC - 24 V DC
Floating voltage (U_n) set at half-load and 25°C	13.6 V (12 V) - 27.2 V (24 V)	13.6 V (12 V) - 27.2 V (24 V)
Short-circuit current limitation	From I_n to $I_n + 15%$ for output voltage > 50% of U_n	

> For reliable output voltage	
Protection against external attack	<ul style="list-style-type: none"> - Resistance to all types of external aggressions: <ul style="list-style-type: none"> • Overvoltages encountered on the mains network (lightning, industrial, isolation fault on impedance-earthed neutral system, etc.) • Short-circuit on the primary power supply by a slow-blow fuse on the phase. • Differential mode shock waves by varistor and fuse. • Battery polarity inversions. • Overvoltages on secondary. • Overcurrents and short-circuits at secondary. • Short-circuits inside the product, protected by primary fuse. • Increases in external temperatures (outside the specified range)
Charger current limitation control	<ul style="list-style-type: none"> - Output current limitation allows a charging cycle to be started with a discharged battery. <ul style="list-style-type: none"> • Protects the product completely from short-circuits on the installation. • Protection selectivity is provided by fuses on each load output and the battery fuse.
High-performance regulation and filtering	<ul style="list-style-type: none"> - Particularly efficient output voltage regulation <ul style="list-style-type: none"> • Dynamic regulation < 5% of U_n for cumulative variations of the mains and the load (from 10% to 90%). - Enhanced filtering, which eliminates all interference and reduces the ripple on the DC output voltage. Battery capacity preserved and a guarantee of optimum system operation. <ul style="list-style-type: none"> • LF rms ripple < 0.2% U_n. • HF ripple (20 MHz-50 Ω) < 4% U_n. <p><i>Note: The AXS3 and AXRS ranges can operate without battery and may be used as a direct power supply.</i></p>
> For emergency power source control	
System control	<ul style="list-style-type: none"> - Monitoring of: <ul style="list-style-type: none"> • The status of mains, battery and load fuses. • Battery voltage. • Its operating status. • Mains voltage present in the correct operating range.
Battery charge management	<ul style="list-style-type: none"> - This function is essential for reaching the design life and to ensure optimum operation of the battery. <ul style="list-style-type: none"> • The load voltages are factory set for "sealed" recombination-type lead acid batteries. • They are consistent with the battery manufacturers' recommendations. • The charger features battery charging current limitation. • Supplying power to the load takes priority over battery charging. - The battery current limit is adjustable by the customer depending on the battery capacity to ensure recharge between 0.1 and 0.3C recommended by the manufacturers. <ul style="list-style-type: none"> • The thresholds are 25%, 50% and 75% of rated current. • The selection is made by 2 microswitches. • The default load current is 75% of rated current. - A battery voltage compensation system maintains the charge characteristics within the limits specified by the battery manufacturer across the whole of the operational temperature range. A probe placed close to the batteries measures the temperature thereof.
Battery backup	<ul style="list-style-type: none"> - Automatic disconnection of the battery at end of discharge to preserve its future capacity. <ul style="list-style-type: none"> • Prevents excessively deep discharge that can permanently downgrade performance (cut-out threshold 1.8V/cell). • An alarm is sent before disconnection (Pre-cut alarm threshold 1.85 V/ cell). • In autonomous operation, up to the cut-off threshold, the design of the SLAT unit significantly limits the charger's own consumption on the battery. • This allows your application to take full advantage of the battery's capacity.

> **Charger consumption on the battery during autonomy**

	12 V DC	24 V DC
50 W	31.5 mA	38.5 mA
75 W	31.5 mA	38.5 mA

> **For optimal communication**

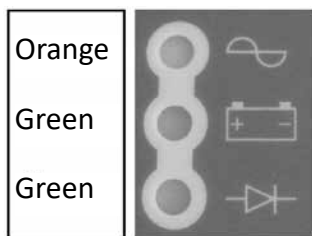

Display and remote reporting of the information

3 LEDs on card indicate the 3 fault states. Signaling failure orange LED if fault, green otherwise.

- **Mains fault:**

- If mains not present.

- **Charger fault:**

- If no voltage on Output 1.
- If no voltage on Output 2.
- If low voltage outputs (product overload).
- If the mains fuse is blown or not present.
- If the product is out of order.

- **Battery fault:**

- Battery fault if no battery (test every 30 seconds during the first 20 minutes after start-up and test every 15 minutes maximum. If a fault is detected, the test is conducted every 30 seconds, and continues up to 20 minutes after the fault disappears).
- If battery voltage < 1.85 V/cell +/-3%.
- If the internal impedance is too high (test every 4 hours maximum on a charged battery).

A switch with a wired contact loop detects when the cover is opened or the unit is removed from the wall.

On motherboard

A LED on the motherboard indicates the operational status before the cabinet is closed (display board not connected) or when no display board exists.

Signals:

- All OK: green
- Faults: red

Communication AXS3

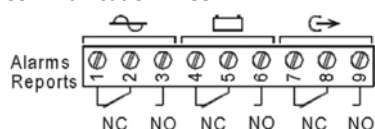

The 3 faults (mains, battery, output) are reported on 3 independent dry contacts NC / NO (failsafe).
Dry contact: 1A @ 24 V DC, 0.3A @ 125 V AC.
An additional tamper dry contact is provided, grouping cover opening and wall detachment.

Communication AXRS*

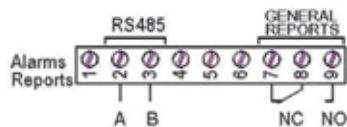

*Exists with RS485 communication. For more information, contact us.

- The 3 faults (mains, battery, charger) and opening of the cover and removal from the wall data are grouped one single dry contact (failsafe).
- Dry contact: 1 A @ 24 V DC, 0.3 A @ 125 V AC.
- A serial RS485 link (Modbus) allows to know precisely the fault information mentioned above and communicates the analog values (user's, battery's, charger's voltages and currents, battery temperature).
- The power supply is addressed by two microswitches (4 possible addresses).

> **Connection specifications**

50 W - 75 W

Mains	1x3pin/0.2 - 2.5 mm ² /15 A
Batteries	1x2pin/0.2 - 2.5 mm ² /15 A
Load (2 outputs)	1x2pin/0.2 - 2.5 mm ² /15 A
Alarm reports	1x9pin/0.2 - 1.5 mm ² /14.5 A

All terminal blocks are removable with screen printing on the mobile card.

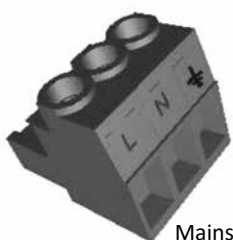

Mains



Output

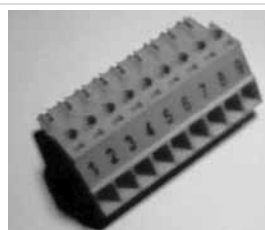

Communication

> Options				
3 or 5 fuse outputs kit	<ul style="list-style-type: none"> • Customer installable Printed Circuit Board. • Secured by 4 clips on the motherboard. • Connectors with 2.5 mm² screw terminals. • 5 x 20 fuse, rating 4 A. 			
> Cabinet characteristics				
Cabinet	Dimension W x H x D (mm)	IP	Base	Cover
C24	322 x 248 x 126	IP30	Metal, RAL 9006	ABS RAL 9003
C38	289 x 350 x 189	IP31	Metal, RAL 7035	Metal, RAL 7035
C85	408 x 408 x 224	IP31	Metal, RAL 7035	Metal, RAL 7035
> Types of battery cabinet				
Cabinet	Type	12 V DC		24 V DC
C24	Wall-mounted	7 Ah, 12 Ah, 24 Ah (2 x 12 Ah)		7 Ah, 12 Ah
C38	Wall-mounted & Floor-mounted	17 Ah, 24 Ah, 38 Ah		17 Ah, 24 Ah
C85	Wall-mounted & Floor-mounted	48 Ah (2 x 24 Ah), 65 Ah (3 x 12 Ah), 80 Ah, 96 Ah (4 x 24 Ah)		24 Ah, 38 Ah, 48 Ah (4 x 24 Ah)
> Associated battery capacities				
Charger voltage	12 V DC		24 V DC	
Charger ratings	4 A	6 A	2 A	3 A
Maximum battery charging current	3 A	4.5 A	1.5 A	2.25 A
Maximum capacity C20 - 1.75 V	50 Ah	86 Ah	26 Ah	40 Ah
Minimum capacity C20 - 1.75 V	7 Ah	7 Ah	7 Ah	7 Ah

SLAT can change specifications on his products without prior notice.

THE QUALITY OF YOUR VDI SERVICES IS BETTER WITH SLAT POWER SUPPLIES



Modern buildings are wired to transit the ever-increasing amount of information we exchange. With less than an average of 6 hours of downtime a year, we might think that our power grid is enough to power our entire communication infrastructure. However, the reality is different. The network is strongly degraded in our buildings by the powerful elevator or air-conditioning motors, the switching operations of the electrical network's protection components or the disturbances generated by new wireless applications.

For 30 years, SLAT power supplies for **voice, data and image applications** have been tracking technological changes to provide the best filtering and continuity of power for a quality communication service.

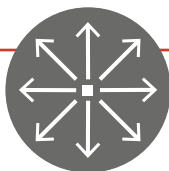
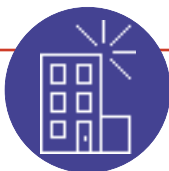

SELECTION GUIDE

	EVOLUTION			RMS IP			SDC-PoE	SDC-PoE 8	SDC-PoE 24
DC output voltage	12 V	24 V	48 V	12 V	24 V	48 V	55 V	-	-
Current / Power	6 A/8 A/12 A/ 16 A/24 A/32 A /48 A	3 A/4 A/6 A/ 8 A/ 12 A/ 16 A/ 24 A	2 A/3 A/ 4 A/6 A/ 8 A/ 12 A	24 A/ 48 A	12 A/ 24 A	6 A/ 12 A	55 W	180 W	210 W
Number of terminal outputs	2 / 4* / 6*			5			1	-	-
PoE/PoE+ ports	-			-			1	8	Up to 22
HiPoE ports	-			-			-	4	-
Ethernet ports	-			1			1	-	-
SFP Ports	-			-			-	2	Up to 4
Dry contact	3			-			1	1	-
HMI	4 LEDs			Display			4 LEDs	18 LEDs	68 LEDs
IP Communication (SNMP)	-			Yes			Yes	Yes	Yes
Format	Box or Rack			Rack			DIN	DIN	Rack
Battery technology	Lead			Lead			Lithium	Lithium	Lithium
Battery control/ protection	Yes			Yes			Yes	Yes	Yes
Battery capacity	Without battery			Compatible with batteries up to			D	F	F
	7 Ah 12 Ah 17 Ah 24 Ah 36 Ah 38 Ah 48 Ah 65 Ah 80 Ah 96 Ah 120 Ah 130 Ah 140 Ah	7 Ah 12 Ah 17 Ah 24 Ah 38 Ah 48 Ah 65 Ah 80 Ah 120 Ah 130 Ah 170 Ah	2,1 Ah 7 Ah 12 Ah 17 Ah 24 Ah 38 Ah 65 Ah 80 Ah	320 Ah	140 Ah	80 Ah	G		J
Page	42			42			112	120	125

*with option



EVOLUTION



Emergency power supplies with batteries - Multi-Applications

12 V DC • 24 V DC • 48 V DC



Communication by LED on the front panel • Dry Contact

The EVOLUTION Emergency power supplies with batteries provide permanent and backup power for all installations.



Main functions

- ~ Resists short-circuits on load outlets
- ~ Controls and reports operating status
- ~ Monitors battery presence
- ~ Protects the battery at end of discharge
- ~ The installation is available as soon as the mains returns





Benefits of the EVOLUTION range

- ~ Two independent fuse-protected load outlets
- ~ Optional: 3 feeder or 5 feeder printed circuit board
- ~ Optional: parallel or redundancy box
- ~ Dimensioned to operate 24/7 at rated power
- ~ Built-in lightning protection

AB = With battery
SB = Without battery

MODEL	WEIGHT (kg)	SIZE W x H x D	CODE
EVOLUTION 12V			
EV 12V 6A C24 SB	2.0 kg	322 x 248 x 126	1520624000
EV 12V 6A C24 AB 7AH	5.0 kg	322 x 248 x 126	1520624007
EV 12V 6A C24 AB 12 AH	6.0 kg	322 x 248 x 126	1520624012
EV 12V 6A C24 AB 24 AH	12.0 kg	322 x 248 x 126	1520624024
EV 12V 6A C38 SB	5.0 kg	289 x 350 x 189	1520638000
EV 12V 6A C38 AB 40AH	20.0 kg	289 x 350 x 189	1520638040
EV 12V 8A C24 SB	2.0 kg	322 x 248 x 126	1520824000
EV 12V 8A C24 AB 12 AH	6.0 kg	322 x 248 x 126	1520824012
EV 12V 8A C24 AB 24 AH	12.0 kg	322 x 248 x 126	1520824024
EV 12V 8A C38 SB	5.0 kg	289 x 350 x 189	1520838000
EV 12V 8A C38 AB 40AH	20.0 kg	289 x 350 x 189	1520838040
EV 12V 8A F3U	3.0 kg	482 x 132 x 110	1520830000
EV 12V 12A C6	1.0 kg	194 x 243 x 97	1521207000
EV 12V 12A F3U	3.0 kg	482 x 132 x 110	1521230000
EV 12V 16A C23	2.0 kg	248 x 322 x 126	1521624000
EV 12V 16A C85 SB	10.0 kg	408 x 408 x 224	1521685000
EV 12V 16A C85 AB 65AH	34.0 kg	408 x 408 x 224	1521685065
EV 12V 16A RACK	3.0 kg	483 x 132 x 235	1521630000
EV 12V 24A C23	2.0 kg	248 x 322 x 126	1522424000
EV 12V 24A RACK	3.0 kg	483 x 132 x 235	1522430000
EV 12V 32A C23	2.0 kg	248 x 322 x 126	1523224000
EV 12V 48A C180 SB	20.0 kg	505 x 610 x 430	1524818000
EV 12V 48A RACK	4.0 kg	483 x 132 x 395	1524830000
EVOLUTION 24V			
EV 24V 3A C24 SB	2.0 kg	322 x 248 x 126	1540324000
EV 24V 3A C24 AB 7 AH	8.0 kg	322 x 248 x 126	1540324007
EV 24V 3A C38 SB	5.0 kg	289 x 350 x 189	1540338000
EV 24V 3A C38 AB 24 AH	25.0 kg	289 x 350 x 189	1540338024

MODEL	WEIGHT (kg)	SIZE W x H x D	CODE
EVOLUTION 24V (CONTINUATION)			
EV 24V 4A C24 SB	2.0 kg	322 x 248 x 126	1540424000
EV 24V 4A C24 AB 7 AH	8.0 kg	322 x 248 x 126	1540424007
EV 24V 4A C24 AB 12 AH	10.0 kg	322 x 248 x 126	1540424012
EV 24V 4A C38 SB	5.0 kg	289 x 350 x 189	1540438000
EV 24V 4A C38 AB 24 AH	25.0 kg	289 x 350 x 189	1540438024
EV 24V 6A C6	1.0 kg	194 x 243 x 97	1540607000
EV 24V 6A C24 SB	2.0 kg	322 x 248 x 126	1540624000
EV 24V 6A C24 AB 12 AH	10.0 kg	322 x 248 x 126	1540624012
EV 24V 6A C38 SB	5.0 kg	289 x 350 x 189	1540638000
EV 24V 6A C38 AB 17Ah	17.0 kg	289 x 350 x 189	1540638017
EV 24V 6A C38 AB 24 AH	25.0 kg	289 x 350 x 189	1540638024
EV 24V 6A F3U	3.0 kg	483 x 132 x 110	1540630000
EV 24V 8A C23	2.0 kg	248 x 322 x 126	1540824000
EV 24V 8A C48 SB	9.0 kg	425 x 345 x 120	1540848000
EV 24V 8A C48 AB 24 AH	29.0 kg	425 x 345 x 120	1540848024
EV 24V 8A C85 SB	10.0 kg	408 x 408 x 224	1540885000
EV 24V 8A C85 AB 40AH	40.0 kg	408 x 408 x 224	1540885040
EV 24V 8A RACK	3.0 kg	483 x 132 x 235	1540830000
EV 24V 12A C23	2.0 kg	248 x 322 x 126	1541224000
EV 24V 12A C48 SB	9.0 kg	425 x 345 x 120	1541248000
EV 24V 12A C48 AB 24 AH	29.0 kg	425 x 345 x 120	1541248024
EV 24V 12A C85 SB	10.0 kg	408 x 408 x 224	1541285000
EV 24V 12A C85 AB 40AH	40.0 kg	408 x 408 x 224	1541285040
EV 24V 16A C23	2.0 kg	248 x 322 x 126	1541624000
EV 24V 16A C48 SB	9.0 kg	425 x 345 x 120	1541648000
EV 24V 16A C48 AB 24 AH	29.0 kg	425 x 345 x 120	1541648024
EV 24V 16A C180 SB	20.0 kg	505 x 610 x 430	1541618000
EV 24V 16A C180 AB 65AH	68.0 kg	505 x 610 x 430	1541618065
EV 24V 16A C180 AB 90AH	80.0 kg	505 x 610 x 430	1541618090
EV 24V 16A RACK	3.0 kg	483 x 132 x 235	1541630000
EV 24V 24A C23	2.0 kg	248 x 322 x 126	1542424000
EV 24V 24A C180 SB	20.0 kg	505 x 610 x 430	1542418000
EV 24V 24A RACK	3.0 kg	483 x 132 x 235	1542430000
EVOLUTION 48V			
EV 48V 2A C24 SB	2.0 kg	322 x 248 x 126	1580224000
EV 48V 2A C24 AB 2,1 AH	6.0 kg	322 x 248 x 126	1580224002
EV 48V 3A C6	1.0 kg	194 x 243 x 97	1580307000
EV 48V 3A C38 SB	5.0 kg	289 x 350 x 189	1580338000
EV 48V 3A C38 AB 12AH	21.0 kg	289 x 350 x 189	1580338012
EV 48V 4A C23	2.0 kg	248 x 322 x 126	1580424000
EV 48V 4A C48 SB	9.0 kg	425 x 345 x 120	1580448000
EV 48V 4A C48 AB 12AH	25.0 kg	425 x 345 x 120	1580448012
EV 48V 4A RACK	3.0 kg	483 x 132 x 235	1580430000
EV 48V 6A C23	2.0 kg	248 x 322 x 126	1580624000
EV 48V 6A C48 SB	9.0 kg	425 x 345 x 120	1580648000
EV 48V 6A C48 AB 12AH	25.0 kg	425 x 345 x 120	1580648012
EV 48V 6A C85 SB	10.0 kg	408 x 408 x 224	1580685000
EV 48V 6A C85 AB 24AH	50.0 kg	408 x 408 x 224	1580685024
EV 48V 8A C23	2.0 kg	248 x 322 x 126	1580824000
EV 48V 8A C48 SB	9.0 kg	425 x 345 x 120	1580848000
EV 48V 8A C48 AB 12AH	25.0 kg	425 x 345 x 120	1580848012
EV 48V 8A RACK	3.0 kg	483 x 132 x 235	1580830000
EV 48V 12A C23	2.0 kg	248 x 322 x 126	1581224000
EV 48V 12A C180 SB	20.0 kg	505 x 610 x 430	1581218000
EV 48V 12A C180 AB 65AH	116.0 kg	505 x 610 x 430	1581218065
EV 48V 12A RACK	3.0 kg	483 x 132 x 235	1581230000
OPTIONS			
OPTION KIT 3 DEPARTS FUSIBLES	-	-	9900080000
OPTION CARTE 5 DEPARTS FUSIBLES	-	-	9059050004
A RK TCR -COMMUN	4.8 kg	485 x 44 x 430	9189000002
DES COFFRET TCR C7	1.8 kg	243 x 194 x 97	9189000001

> Ratings							
	75 W	100 W	150 W	200 W	300 W	400 W	600 W
12 V DC	6 A	8 A	12 A	16 A	24 A	32 A	48 A
24 V DC	3 A	4 A	6 A	8 A	12 A	16 A	24 A
48 V DC	-	2 A	3 A	4 A	6 A	8 A	12 A
The currents (I_n) shown are at rated output power.							
> Standard-based specifications							
Safety	• EN IEC 62368-1 (2020) + A11 (2020)						
EMC - Immunity	• EN IEC 61000-6-1 (2019) • EN IEC 61000-6-2 (2019)						
EMC - Emissions	• EN IEC 61000-3-2 (2019) • EN IEC 61000-6-3 (2021) • EN IEC 61000-6-4 (2019) • EN 55032 class B						
Environmental	This product range complies with the environmental policy (ISO 14001, RoHS and WEEE).						
	   						
> Environmental specifications							
Relative humidity	During storage: 10% to 95% non-condensing relative humidity In operation: 20% to 95% non-condensing relative humidity						
Storage temperature	-25°C to +85°C						
Operating temperature	Efficiency	75 W - 100 W			150 W - 600 W		
	75% of load	-5°C to +50°C			-5°C to +50°C		
	100% of load	-5°C to +50°C			-5°C to +40°C		
Altitude	Above 2,000 m, the maximum temperature decreases by 5% every 1,000 m						
MTBF	200,000 h at 25°C (external environment) and 75% of load, product installed in a cabinet						
> Input characteristics							
Voltage	99 to 264 V AC single-phase						
Frequency	45 to 65 Hz						
Neutral systems	TT - TN - IT						
Inrush current	limited by CTN						
Upstream circuit breaker to be provided	Bipolar D curve						
Class	Class I						
<i>Note: For the 100 W - 150 W range: 198 to 264 V AC</i>							
	75 W	100 W	150 W	200 W	300 W	400 W	600 W
Mains consumption @198 V	0.5 A	0.75 A	1 A	1.5 A	2 A	3 A	4 A
Output	75 W	100 W - 150 W		200 W - 300 W		400 W - 600 W	
Efficiency at 20% load	71%	75%		84%		85%	
Efficiency at rated load	85%	84%		90%		91%	
> Output characteristics							
Rated voltage	12 V DC		24 V DC		48 V DC		
Floating voltage (U_n) set at half-load and at 25°C	13.6 V +/-0.5%		27.2 V +/-0.5%		54.4 V +/-0.5%		
Adjustment range in power supply mode only	12 V - 14 V		23 V - 29 V		46 V - 58 V		
Charger current limitation	I_n						

> For reliable output voltage			
Protection against external aggressions	<p>- Resistance to all types of external aggressions:</p> <ul style="list-style-type: none"> • Overvoltages encountered on the mains network (lightning, industrial, isolation fault on impedance-earthed neutral system...). • Short-circuit on the primary power supply by a slow blow fuse on the phase. • Differential mode shock waves by varistor and fuse. • Battery polarity inversions. • Overvoltages on secondary. • Overcurrents and short-circuits on secondary. • Short-circuits inside the product, protected by primary fuse. • Increases in external temperatures (outside the specified range). 		
Charger current limitation	<p>- Output current limitation allows a charge cycle to be started on an empty battery.</p> <ul style="list-style-type: none"> • Completely protects the product from short-circuits on the installation. • Protection selectivity is ensured by fuses on each load output and the battery. 		
High performance filtering and regulation	<p>- Particularly efficient output voltage regulation</p> <ul style="list-style-type: none"> • Static regulation < 0.5% of U_n. • Dynamic regulation < 5% of U_n for cumulative variations of the mains and the load (from 10% to 90%). <p>- Enhanced filtering that eliminates all noise and reduces the ripple on the DC output. Battery capacity preserved and the guarantee of optimum system operation.</p> <ul style="list-style-type: none"> • LF rms ripple < 0.2% of U_n • HF ripple (20 MHz-50 Ω) < 4% of U_n. <p><i>Note: The EVOLUTION range can operate without battery and may be used as a direct power supply.</i></p>		
> For the control of the emergency power source			
System control	<p>- Monitoring of:</p> <ul style="list-style-type: none"> • The status of mains, battery and load fuses. • Battery presence or absence. • The temperature inside the cabinet (200 W to 600 W). • Battery voltage and its operating status. • Mains voltage present in the correct operating range. 		
Battery charge management	<p>- This function is essential for reaching the design life and to ensure optimum operation of the battery.</p> <ul style="list-style-type: none"> • The charge voltages are factory set for «sealed» recombination-type lead acid batteries. • They are consistent with the battery manufacturers' recommendations. • The charger features battery charge current limitation. • The supply of power to the load takes priority over the battery charge. 		
Battery backup	<p>- Automatic disconnection of the battery at end of discharge to preserve its future capacity.</p> <ul style="list-style-type: none"> • Prevents deep discharge that can permanently downgrade performance (cut-off threshold 1.8 V/cell +/- 0.5%). • A report is sent before disconnection (Pre-cut-off alarm threshold 1.85 V/cell +/- 0.5%). • Very low internal consumption. • This allows your application to take full advantage of the battery's capacity. 		
> Charger consumption on the battery during autonomy			
	12 V DC	24 V DC	48 V DC
75 W	32 mA	39 mA	-
100 W - 150 W	49 mA	75 mA	85 mA
200 W - 300 W	65 mA	45 mA	37 mA
400 W - 600 W	141 mA	106 mA	73 mA

> For optimal communication



Displaying and remote reporting of the information

- Mains:

- Presence indicated by a green LED.
- Remote reporting by dry contact with delay (failsafe).

- Charger:

- Correct operation indicated by a green LED.
- Charger fault if mains fuse is out of order or not present, or if product is out of order.
- Remote reporting by dry contact with delay (failsafe).

- Output:

- Voltage presence (no threshold) on the load outputs indicated by green LED.
- If either of the two outputs has no voltage, the LED will go out.
- No associated relay.

- Battery:

- Presence indicated by a green LED.
- Battery fault, if battery is not present (test every 30 seconds for the 1st 20 minutes after the installation, then every 15 min) or if battery voltage < 1.85 V/cell in autonomous mode.
- Voltage of less than 1.85 V/cell indicated by flashing orange LED (autonomous mode).
- Remote reporting by dry contact with delay (failsafe).

Comment:

- In the case of C6 cabinet installation, signaling is accomplished by a single indicator light:
- No fault: green
- Mains fault: orange
- Battery or charger fault, or output load not present: red (this fault takes priority over a mains fault).

- Internal signaling on the motherboard

A LED on the motherboard indicates operational status before the cabinet is closed (display board not connected).

Signals:

- All OK: green
- Mains fault: orange
- Battery or charger fault, or output load not present: red (this fault takes priority over a mains fault).

> Connection specifications

Screw terminal	75 W	100 W - 150 W	200 W - 300 W	400 W - 600 W
Mains	2.5 mm ²	2.5 mm ²		2.5 mm ²
Batteries	2.5 mm ²	6 mm ²		10 mm ²
Load (2 outputs)	2.5 mm ²	6 mm ²		10 mm ²
Alarm reports*	1.5 mm ²	1.5 mm ²		1.5 mm ²

*the alarm report connector is unpluggable

Note: the battery and 12 V/48 A load terminals are 35 mm²

> Options

3 or 5 fuse output kit	<ul style="list-style-type: none"> • Customer installable printed circuit board. • Secured by 4 clips on the motherboard. • Connectors with 2.5 mm² screw terminals. • Fuse 5 x 20 rating 4 A.
Omega DIN rail mounting kit	<ul style="list-style-type: none"> • Adapter for mounting the C6 and C23 cabinet on a DIN type rail
Digital display on C85 cabinet.	in quantity, consult us.
TCR cabinet	For redundancy, maximal current 40 A.

> Cabinet and rack characteristics				
Version	Size W x H x D (mm)	IP	Base	Cover
C6	194 x 243 x 97	IP30	Metal, RAL 9006	ABS RAL 9003
C23	248 x 322 x 126	IP30	Metal, RAL 9006	ABS RAL 9003
C24	322 x 248 x 126	IP30	Metal, RAL 9006	ABS RAL 9003
C38	289 x 350 x 189	IP31	Metal, RAL 7035	Metal, RAL 7035
C48	425 x 345 x 120	IP30	Metal, RAL 9006	ABS RAL 9003
C85	408 x 408 x 224	IP31	Metal, RAL 7035	Metal, RAL 7035
C180	505 x 610 x 430	IP31	Metal, RAL 7035	Metal, RAL 7035
Rack F3U	482 x 132 x 110	IP30	Metal, RAL 7035	Metal, RAL 7035
Rack	483 x 132 x 235	IP30	Metal, RAL 7035	Metal, RAL 7035
> Types of battery cabinets				
Version	Type	12 V DC	24 V DC	48 V DC
C6	Wall-mounted & Floor-mounted	-	-	-
C23	Wall-mounted	-	-	-
C24	Wall-mounted	7 Ah, 12 Ah, 24 Ah (2 x 12 Ah)	7 Ah, 12 Ah	2.1 Ah
C38	Wall-mounted & Floor-mounted	17 Ah, 24 Ah, 38 Ah	17 Ah, 24 Ah	7 Ah, 12 Ah
C48	Wall-mounted	24 Ah (2 x 12 Ah), 36 Ah (3 x 12 Ah), 48 Ah (4 x 12 Ah)	7 Ah, 12 Ah, 24 Ah (4 x 12 Ah)	7 Ah, 12 Ah
C85	Wall-mounted & Floor-mounted	48 Ah (2 x 24 Ah), 65 Ah, 80 Ah, 96 Ah (4 x 24 Ah)	24 Ah, 38 Ah, 48 Ah (4 x 24 Ah)	12 Ah, 17 Ah, 24 Ah
C180	Floor-mounted	120 Ah, 130 Ah, 140 Ah	65 Ah, 80 Ah, 120 Ah, 130 Ah, 170 Ah	38 Ah, 65 Ah, 80 Ah
Rack F3U	Rack	-	-	-
Rack	Rack	-	-	-

SLAT can change specifications on his products without prior notice.



Communication via dry contact

FIT'IN emergency power supplies provide permanent and backup power for all installations.



CG1
130 x 104 x 41 mm



CG2
125 x 177 x 68 mm



CG3
182 x 231 x 73 mm



CG4
215 x 265 x 77 mm





Main functions

- ~ Card protection, DIN rail mounting.
- ~ Battery charger function.
- ~ Resists short-circuits on load outlets.
- ~ The installation resumes as soon as the mains returns.

Benefits of the FIT'IN range

- ~ Two independent fuse-protected load outlets.
- ~ Dimensioned to operate 24/7 at rated power.
- ~ Built-in lightning protection.
- ~ Fits easily into an enclosure or cabinet.
- ~ Inaudible.

MODEL	WEIGHT (kg)	SIZE W x H x D (mm)	CODE	PACK
FIT'IN 12V				
FITIN 12V 6A CG1	0.5 kg	130 x 104 x 41	1520601000	-
FITIN 12V 6A CG1 Q16	0.5 kg	130 x 104 x 41	1520613000	16
FITIN 12V 12A CG2	1.0 kg	125 x 177 x 68	1521202000	-
FITIN 12V 12A CG2 Q16	1.0 kg	125 x 177 x 68	1521214000	16
FITIN 12V 24A CG3	2.2 kg	182 x 231 x 73	1522403000	-
FITIN 12V 24A CG3 Q8	2.2 kg	182 x 231 x 73	1522415000	8
FITIN 12V 32A CG4	3.5 kg	215 x 265 x 77	1523204000	-
FIT'IN 24V				
FITIN 24V 3A CG1	0.5 kg	130 x 104 x 41	1540301000	-
FITIN 24V 3A CG1 Q16	0.5 kg	130 x 104 x 41	1540313000	16
FITIN 24V 6A CG2	1.0 kg	125 x 177 x 68	1540602000	-
FITIN 24V 6A CG2 Q16	1.0 kg	125 x 177 x 68	1540614000	16
FITIN 24V 12A CG3	2.2 kg	182 x 231 x 73	1541203000	-
FITIN 24V 12A CG3 Q8	2.2 kg	182 x 231 x 73	1541215000	8
FITIN 24V 24A CG4	3.5 kg	215 x 265 x 77	1542404000	-
FITIN 24V 24A CG4 Q4	3.5 kg	215 x 265 x 77	1542416000	4
FIT'IN 48V				
FITIN 48V 3A CG2	1.0 kg	125 x 177 x 68	1580302000	-
FITIN 48V 3A CG2 Q16	1.0 kg	125 x 177 x 68	1580314000	16
FITIN 48V 6A CG3	2.2 kg	182 x 231 x 73	1580603000	-
FITIN 48V 6A CG3 Q8	2.2 kg	182 x 231 x 73	1580615000	8
FITIN 48V 12A CG4	3.5 kg	215 x 265 x 77	1581204000	-
FITIN 48V 12A CG4 Q4	3.5 kg	215 x 265 x 77	1581216000	4

> Ratings				
	75 W	150 W	300 W	600 W
12 VDC	6 A	12 A	24 A	32 A
24 VDC	3 A	6 A	12 A	24 A
48 VDC	-	3 A	6 A	12 A
The currents (I_n) shown are at rated output power.				
> Standard-based specifications				
Safety	• EN IEC 62368-1 (2020) + A11 (2020)			
EMC - Immunity	• EN IEC 61000-6-1 (2019) • EN IEC 61000-6-2 (2019)			
EMC - Emissions	• EN IEC 61000-3-2 (2019) • EN IEC 61000-6-3 (2021) • EN IEC 61000-6-4 (2019) • EN 55032			
Environmental	This product range complies with the environmental policy (ISO 14001, RoHS and WEEE).			
	   			
> Environmental specifications				
Relative humidity	During storage: 10% to 95% non-condensing relative humidity During operation: 20% to 95% non-condensing relative humidity			
Storage temperature	-25°C to +85°C			
Operating temperature	Power	75 W	100 W - 600 W	
	75% of load	-5°C to +50°C	-5°C to +50°C	
	100% of load	-5°C to +50°C	-5°C to +40°C	
Altitude	Above 2,000 m, the maximum temperature decreases by 5% every 1,000 m			
MTBF	200,000 h at 25°C (external environment) and 75% of load, product installed in a cabinet			
> Input characteristics				
Voltages	99 to 264 V AC single-phase (75W - 300 W - 600 W) 198 to 264 V AC single-phase (150 W)			
Frequency	45 to 65 Hz			
Neutral systems	TT - TN - IT			
Inrush current	limited by NTC			
Upstream circuit breaker required	Curve D			
Class	Class I			
	75 W	150 W	300 W	600 W
Mains consumption @198 V	0.5 A	1 A	2 A	4 A
Efficiency at 20% load	71%	75%	84%	85%
Efficiency at rated load	85%	84%	90%	91%
> Output characteristics				
Rated voltage	12 V DC	24 V DC	48 V DC	
Floating voltage (U_n) set at half-load and at 25°C	13.6 V +/-0.5%	27.2 V +/-0.5%	54.4 V +/-0.5%	
Adjustment range in power supply mode only	12 V - 14 V	23 V - 29 V	46 V - 58 V	
Charger current limitation	From I_n to I_n +15%			

> For reliable output voltage	
Protection against external aggressions	<ul style="list-style-type: none"> - Resistance to any type of external aggression: <ul style="list-style-type: none"> • Overvoltages encountered on the mains network (lightning strikes, industrial environment, isolation fault on impedance-earthed neutral system, etc.) • Short-circuit on the primary power supply primary by a slow blow fuse on the phase. • Differential mode shock waves by varistor and fuse. • Inversions of battery polarity. • Overvoltages on the secondary power supply. • Overcurrents and short-circuits on the secondary power supply. • Short-circuits inside the product, protected by primary fuse. • Increases in external temperatures (outside the specified range).
Charger current limitation	<ul style="list-style-type: none"> - The output current limitation allows to start a charge cycle on an empty battery • Completely protects the product from short-circuits on the installation. • The selectivity of the protection is ensured by the fuses on each output use and the battery fuse.
High performance filtering and regulation	<ul style="list-style-type: none"> - Particularly efficient output voltage regulation <ul style="list-style-type: none"> • Static regulation < 0.5% of U_n. • Dynamic regulation < 5% of U_n for cumulative variations of the mains and the load (10% to 90%). - Enhanced filtering that eliminates all parasites and reduces the ripple on the V DC output. Battery capacity preserved and guarantee of optimum system operation. <ul style="list-style-type: none"> • LF rms ripple < 0.2% of U_n. • HF ripple (20 MHz-50 Ω) < 4% of U_n.

> For the control of the emergency power source	
System control	<p>Monitoring of:</p> <ul style="list-style-type: none"> • Status of mains, battery and load fuses. • Battery presence or absence. • Battery voltage. • Its operating status. • Mains voltage present in the correct operating range.
Battery charge management	<p>This function is essential for reaching the design life and to ensure optimum operation of the battery.</p> <ul style="list-style-type: none"> • The charge voltages are factory adjusted for "sealed" recombination-type lead acid batteries. • They are consistent with the battery manufacturers' recommendations. • The charger includes battery charge current limitation. • The power supply to the load takes priority over the battery charge.
Battery backup	<p>Automatic disconnection of the battery at the end of discharge to preserve its future capacity.</p> <ul style="list-style-type: none"> • Prevents excessively deep discharge, that may permanently downgrade performance (cut-off threshold: 1.8V/cell). • A report is sent before disconnection (pre-cut-off alarm threshold: 1.85V/cell). • Very low internal consumption. • This allows the application to take full advantage of the battery capacity.

> Charger consumption on the battery during autonomy			
	12 V DC	24 V DC	48 V DC
75 W	32 mA	39 mA	-
150 W	49 mA	75 mA	85 mA
300 W	65 mA	44 mA	37 mA
600 W	141 mA	106 mA	73 mA

> Communication

Displaying and remote reporting of the information	<p>- Internal signaling on motherboard: A LED on the motherboard indicates the operational status. Signals:</p> <ul style="list-style-type: none"> • Everything OK: green • Mains fault: orange • Battery or charger fault, or load not present: red (this fault takes priority over a mains fault). <p>- Mains fault: Remote reporting by means of a dry contact with time delay relay (fail-safe).</p> <p>- Charger fault: A charger fault occurs if the mains fuse is out of order or not present, or if the unit is out of order. Remote reporting by means of a dry contact with time delay relay (fail-safe).</p> <p>- Battery fault: A battery fault occurs if the battery is not present or if voltage < 1.85 V/cell in autonomous mode. Remote reporting by means of a dry contact with time delay relay (fail-safe).</p>
--	--

> Connection specifications

Screw terminal	75 W	150 W	300 W	600 W
Mains	2.5 mm ²	2.5 mm ²	2.5 mm ²	2.5 mm ²
Batteries	2.5 mm ²	6 mm ²	6 mm ²	10 mm ²
Load (2 outputs)	2.5 mm ²	6 mm ²	6 mm ²	10 mm ²
Alarm report*	1.5 mm ²	1.5 mm ²	1.5 mm ²	1.5 mm ²

*The alarm report connector can be unplugged

> Boards characteristics

Version	Dimensions W x H x D (mm)	Base	Cover
CG1	130 x 104 x 41	Metal	Grid
CG2	125 x 177 x 68	Metal	Grid
CG3	182 x 231 x 73	Metal	Grid
CG4	215 x 265 x 77	Metal	Grid

SLAT can change specifications on his products without prior notice.

EVOLUTION RMS IP



Emergency power supplies with batteries in a 19" 2U rack IP Management

12 V DC • 24 V DC • 48 V DC



Remote communication over IP and Digital Display

The emergency power supplies of the EVOLUTION RMS IP range provide permanent and backup power for all installations.



Rack 2U - front view
483 x 89 x 395 mm



Rack 2U - back view
483 x 89 x 395 mm





Main functions

- ~ Controls and reports operating status over IP
- ~ Monitors battery presence
- ~ Protects the battery against deep discharge
- ~ Display of status on the front panel

Benefits of the RMS IP range

- ~ Five fuse-protected load outlets
- ~ All connectors are pluggable
- ~ Built-in lightning protection
- ~ Fully-protected product, with rear connectors

MODEL	WEIGHT (kg)	SIZE W x H x D	CODE
EVOLUTION RMS IP 12V			
RMS IP 12V 8A 16A UTIL	3.7 kg	483 x 89 x 395	1521634000
RMS IP 12V 16A 32A UTIL	4.7 kg	483 x 89 x 395	1523234000
EVOLUTION RMS IP 24V			
RMS IP 24V 4A 10A UTIL	3.7 kg	483 x 89 x 395	1541034000
RMS IP 24V 10A 16A UTIL	4.7 kg	483 x 89 x 395	1541634000
EVOLUTION RMS IP 48V			
RMS IP 48V 2A 4A UTIL	3.7 kg	483 x 89 x 395	1580434000
RMS IP 48V 4A 10A UTIL	4.7 kg	483 x 89 x 395	1581034000

> Ratings				
	300 W		600 W	
	I_n	I_{Load}	I_n	I_{Load}
12 V DC	24 A	8 to 16 A	48 A	16 to 32 A
24 V DC	12 A	4 to 10 A	24 A	10 to 16 A
48 V DC	6 A	2 to 4 A	12 A	4 to 10 A
> Standard-based specifications				
Safety	• EN IEC 62368-1 (2020) + A11 (2020)			
EMC - Immunity	• EN IEC 61000-6-1 (2019) • EN IEC 61000-6-2 (2019)			
EMC - Emission	• EN IEC 61000-3-2 (2019) • EN IEC 61000-6-3 (2021) • EN IEC 61000-6-4 (2019) • EN 55032 class B			
Environment	This product range meets the environmental requirements of ISO 14001, RoHS and WEEE Standards.			
	   			
> Environmental specifications				
Humidity	During storage: relative humidity 10% to 95% non-condensing In operation: relative humidity 20% to 95% non-condensing			
Storage temperature	-25°C to +85°C			
Working temperature	Power		300 W - 600 W	
	75% of load		-5°C to +50°C	
	100% of load		-5°C to +40°C	
Altitude	Above 2,000m, the temperature decreases by 5% every 1,000m			
MTBF	200,000 hours at 25°C (ext. environment) and 75% of load, product installed in 19" rack			
> Input specifications				
Voltages	99 to 264 V AC single-phase			
Frequency	45 to 65 Hz			
Neutral system	TT - TN - IT			
Inrush current	limited by CTN			
Upstream circuit breaker required	Bipolar curve D			
Class	Class I			
	300 W		600 W	
Mains consumption @ 198 V	2 A		4 A	
Converter	300 W		600 W	
At 20% load	84%		85%	
At rated load	90%		91%	
> Output specifications				
Rated voltage	12 V DC	24 V DC	48 V DC	
Floating voltage (U_n) set at half-load and 25°C	13.6 V +/-0.5%	27.2 V +/-0.5%	54.4 V +/-0.5%	
Setting range in power supply mode only	12 V - 14 V	23 V - 29 V	46 V - 58 V	
Charger current limitation	I_n			
Load voltage	13.6 V DC	27.2 V DC	54.4 V DC	

> For reliable output voltage			
Protection against external attack	<ul style="list-style-type: none"> - Resistance to all types of external aggressions: <ul style="list-style-type: none"> • Overvoltages encountered on the mains network (lightning, industrial, isolation fault on impedance-earthed neutral system, etc.) • Short-circuit on the primary power supply by a slow-blow fuse on the phase. • Differential mode shock waves by varistor and fuse. • Battery polarity inversions. • Overvoltages on secondary. • Overcurrents and short-circuits at secondary. • Short-circuits inside the product, protected by primary fuse. • Increases in external temperatures (outside the specified range). 		
Charger current limitation control	<ul style="list-style-type: none"> - Output current limitation allows a charging cycle to be started on an empty battery <ul style="list-style-type: none"> • Protects the product completely from short-circuits on the installation. • Protection selectivity is provided by fuses on each load output and the battery fuse. 		
High-performance regulation and filtering	<ul style="list-style-type: none"> - Particularly effective output voltage regulation <ul style="list-style-type: none"> • Static regulation < 0.5% U_n. • Dynamic regulation < 5% U_n for cumulative variations of the mains voltage and the load (from 10% to 90%). - Enhanced filtering which eliminates all interference and reduces the ripple voltage on the DC output. Battery capacity preserved and a guarantee of optimum system operation. <ul style="list-style-type: none"> • LF rms ripple voltage < 0.2% U_n. • HF ripple voltage (20 MHz-50 Ω) < 4% U_n. <p><i>N.B.: the EVOLUTION IP - RMS IP range can work without a battery and be used connected directly to the mains.</i></p>		
> For the control and management of the emergency power source			
System control	<ul style="list-style-type: none"> - Monitoring of: <ul style="list-style-type: none"> • The status of mains, battery and load fuses. • Battery presence or absence. • Battery voltage and its operating status. • Mains voltage present in the correct operating range. 		
Battery charge management	<ul style="list-style-type: none"> - This function is essential to achieve the theoretical design life and to ensure optimum operation of the battery. <ul style="list-style-type: none"> • The load voltages are factory set for "sealed" recombination-type lead acid batteries. • They are consistent with the battery manufacturers' recommendations. • The charger features battery charging current limitation. • Supplying power to the load takes priority over battery charging. 		
Battery backup	<ul style="list-style-type: none"> - Automatic disconnection of the battery at end of discharge to preserve its future capacity. <ul style="list-style-type: none"> • Prevents excessively deep discharge that would permanently downgrade performance (cut-out threshold 1.8V/cell +/-0.5%). • Information is transmitted before disconnection (pre-cut out alarm at 1.85V/cell +/-0.5%). • Very low internal consumption. • This allows your application to take full advantage of the battery's capacity. 		
> Charger consumption on the battery during autonomy			
	12 V	24 V	48 V
300 W	65 mA	45 mA	37 mA
600 W	141 mA	106 mA	73 mA
> IP Communication			
Ethernet configuration	<ul style="list-style-type: none"> - Configuring rack communication settings using a computer. - 2 groups possible: <ul style="list-style-type: none"> • Administrator • User 		
Available languages	<ul style="list-style-type: none"> • French • English • German • Italian • Dutch • Spanish 		

> IP Communication

Management by IP, reports viewed remotely

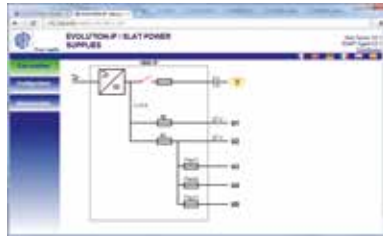

- **The items shown on the Management screen are:**

- Name of managed product.
- Mains present / absent.
- AC / DC converter OK or faulty.
- Fuses OK or faulty.
- Battery switch open / closed.
- Current direction charge / discharge.
- Battery present / battery circuit faulty.
- Low battery: product shutdown imminent, back-up failure.

- **MIB made available upon request from the supervision site.**

Reports viewed locally



- **Display** 16 characters, 1 line:

- Mains voltage.
- Battery voltage and current.
- Load voltage (by load output).
- Information about the various problems (mains, charger, fuse, battery, etc.).

- **Integrated MMI:**

The user can navigate using the push button on the front panel, to the right of the display.

- **Energy-saving function:**

The display automatically goes into standby mode.

> Connection specifications

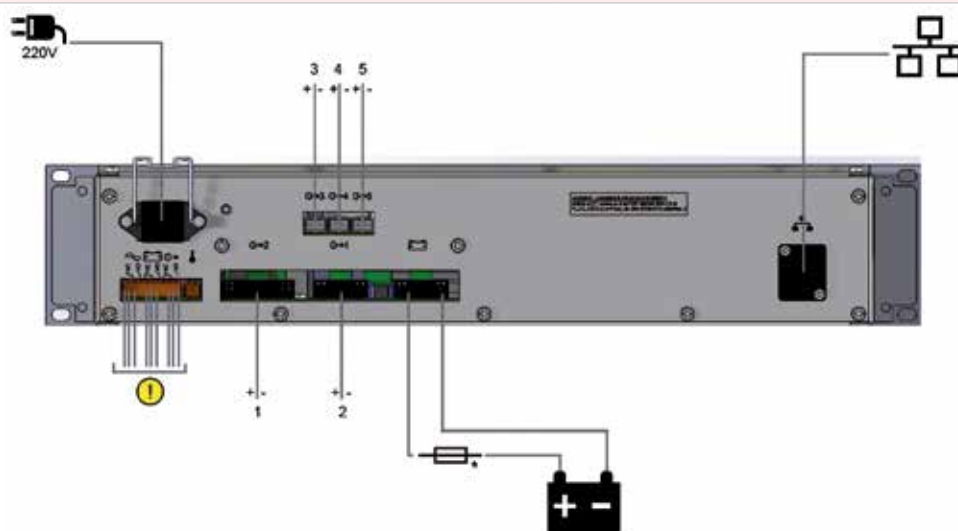

*Fuse not included, to be calibrated according to the maximum load current of the installation.

Plug-in connectors	300 W	600 W
Mains	2.5 mm ²	2.5 mm ²
Battery	6 mm ²	10 mm ²
Load outputs 1 and 2	6 mm ²	10 mm ²
Auxiliary load outputs 3, 4 and 5	1.5 mm ²	1.5 mm ²
Alarm reports	1.5 mm ²	1.5 mm ²
Ethernet cable	cat 5e / cat 6e (RJ45)	cat 5e / cat 6e (RJ45)

> Rack characteristics

	Size W x H x D (mm)	IP	Base	Front panel
2U Rack	483 x 89 x 395	IP30	Metal	Metal, RAL 7035

> Charger I_n summary / I Load / associated battery capacity / VRLA

Designation	I _n (whole charger)	I _{Load}	Maximum battery capacity (C/10)
RMS IP 12V 8A 16A UTIL	24 A	From 8 to 16 A	160 Ah
RMS IP 12V 16A 32A UTIL	48 A	From 16 to 32 A	320 Ah
RMS IP 24V 4A 10A UTIL	12 A	From 4 to 10 A	80 Ah
RMS IP 24V 10A 16A UTIL	24 A	From 10 to 16 A	140 Ah
RMS IP 48V 2A 4A UTIL	6 A	From 2 to 4 A	40 Ah
RMS IP 48V 4A 10A UTIL	12 A	From 4 to 10 A	80 Ah

SLAT can change specifications on his products without prior notice.



DON'T WORRY, YOUR TECHNICAL RESOURCES ARE FULLY OPERATIONAL



Faced with emergencies and the need to save human lives, to provide care and support to people in distress, medical teams must be able to rely on the resources at their disposal. These instruments and equipment must **operate flawlessly, 24 hours a day**, to provide the right response at the right time.

The operational continuity of these resources may sometimes mean the loss of human life, but it always ensures the peace of mind of the nursing staff who have to deal with every situation.

For many years now, SLAT has been supporting the men and women in our care and health centers. Our products provide failure-free power to medical systems, enabling them to provide the operational support that medical teams deserve.

SLAT, reliable solutions that keep technical resources running at all times.



SELECTION GUIDE

	SANTE	FIT'IN			SOC-PoE 8	SOC-PoE 24	ENERGO	
Application	Nurse call and other medical systems	Multi-Application			Multi-Application	Multi-Application	MV/LV substation Control	
Standard	EN 61046	-			-	-	NF C13-100	
DC output voltage	24 V	12 V	24 V	48 V	-	-	24 V	48 V
Current / Power	4 A / 8 A / 12 A / 16 A / 24 A	6 A / 12 A / 24 A / 32 A	3 A / 6 A / 12 A / 24 A	3 A / 6 A / 12 A	180 W	210 W	6 A / 12 A	
Number of terminal outputs	5	2			-	-	2 / 4	
PoE/PoE+ ports	-	-			8	22	-	
SFP ports	-	-			2	4	-	
Format	Box	Card			DIN	Rack	Box	
Battery technology	Lead	Lead			Lithium	Lithium	Lead	Lead or Lithium
Battery control/ protection batterie	Yes	Yes			Yes	Yes	Yes	
Battery capacity	7 Ah 12 Ah 24 Ah 65 Ah	Compatible with batteries up to 240 Ah	Compatible with batteries up to 180 Ah	Compatible with batteries up to 90 Ah	F	F J	7 Ah 14 Ah 24 Ah	
Page	50	38			112	125	55	

*with option





Communication by LED on the front panel • Dry Contact

The SANTE emergency power supplies with batteries provide permanent and backup power for medical and emergency system installations.



C24
322 x 248 x 126 mm



C48
425 x 345 x 120 mm



C180
505 x 610 x 430 mm





Main functions

- ∨ Resists short-circuits on load outlets
- ∨ Controls and reports operating status
- ∨ Monitors battery presence
- ∨ Protects the battery at end of discharge.

Benefits of the SANTE range

- ∨ 5 independent fuse-protected load outlets
- ∨ Dimensioned to operate 24/7 at rated power
- ∨ Built-in lightning protection
- ∨ The installation is available as soon as the mains returns.

MODEL	WEIGHT (kg)	SIZE W x H x D (mm)	CODE
SANTE 24V			
SANTE 24V 4A C24 AB 7 AH	8.0 kg	322 x 248 x 126	3040424007
SANTE 24V 8A C48 AB 12AH	16.0 kg	425 x 345 x 120	3040848012
SANTE 24V 8A C48 AB 24 AH	29.0 kg	425 x 345 x 120	3040848024
SANTE 24V 12A C48 AB 24 AH	29.0 kg	425 x 345 x 120	3041248024
SANTE 24V 16A C48 AB 24 AH	29.0 kg	425 x 345 x 120	3041648024
SANTE 24V 24A C180 AB 65AH	68.0 kg	505 x 610 x 430	3042418065

> Ratings							
	75 W	100 W	150 W	200 W	300 W	400 W	600 W
24 V DC	3 A	4 A	6 A	8 A	12 A	16 A	24 A
The currents (I_n) shown are at rated output power							
> Standards-based specifications							
Safety	• EN IEC 62368-1 (2020) + A11 (2020)						
EMC - Immunity	• EN IEC 61000-6-1 (2019) • EN IEC 61000-6-2 (2019)						
EMC - Emission	• EN IEC 61000-3-2 (2019) • EN IEC 61000-6-3 (2021) • EN IEC 61000-6-4 (2019) • EN 55032 class B						
Specific	• EN 61046						
Environment	This product range is environmental policy ISO 14001, RoHS et WEEE.    						
> Environmental specifications							
Humidity	During storage: relative humidity 10% to 95% (non-condensing) In operation: relative humidity 20% to 95% (non-condensing)						
Storage temperature	-25°C à +85°C						
Operating temperature	Power	75 W - 100 W			150 W - 600 W		
	75% of load	-5°C to +50°C			-5°C to +50°C		
	100% of load	-5°C to +50°C			-5°C to +40°C		
Altitude	Above 2,000 m, the temperature decreases by 5% every 1,000 m						
MTBF	200,000 h at 25°C (external environment) and 75% of load, product installed in a cabinet						
> Input specifications							
Voltages	198 to 264 V AC single-phase						
Frequency	45 to 65 Hz						
Neutral system	TT - TN - IT						
Switch-on current	limited by CTN						
Upstream circuit breaker required	Bipolar D Curve						
Class	I Class						
	75 W	100 W	150 W	200 W	300 W	400 W	600 W
Primary current @ 198 V	0.5 A	0.75 A	1 A	1.5 A	2 A	3 A	4 A
Converter	75 W		100 W - 150 W		200 W - 300 W		400 W - 600 W
At 20% load	71%		75%		84%		85%
At rated load	85%		84%		90%		91%
> Output specifications							
Rated voltage	24 V DC						
Floating voltage (U_n) set at half-load and 25°C	27.2 V +/-0.5%						
Short-circuit current limitation	I_n						

> For reliable output voltage				
Protection against external aggressions	<p>- Resistance to all types of external aggressions:</p> <ul style="list-style-type: none"> • Overvoltages encountered on the mains network (lightning, industrial, isolation fault on impedance-earthed neutral system...). • Short-circuit on the primary power supply by a slow blow fuse on the phase. • Differential mode shock waves by varistor and fuse. • Battery polarity inversions. • Overvoltages on secondary. • Overcurrents and short-circuits on secondary. • The short-circuits inside the product, protected by primary fuse. • Increases in external temperatures (outside the specified range). 			
Charger current limitation	<p>- Output current limitation allows a charge cycle to be started with a discharged battery.</p> <ul style="list-style-type: none"> • Completely protects the product from short-circuits on the installation. • Protection selectivity is ensured by fuses on each load output and the battery fuse. 			
High performance filtering and regulation	<p>- Particularly efficient output voltage regulation</p> <ul style="list-style-type: none"> • Static regulation < 0.5% of U_n. • Dynamic regulation < 5% of U_n for cumulative variations of the mains and the load (from 10% to 90%). <p>- Enhanced filtering that eliminates all parasites and reduces the ripple on the V DC output. Battery capacity preserved and the guarantee of optimum system operation.</p> <ul style="list-style-type: none"> • LF rms ripple < 0.2% of U_n • HF ripple (20 MHz-50 Ω) < 4% of U_n. <p><i>Note: The SANTE range can operate without battery and may be used as a direct power supply.</i></p>			
> For the control of the emergency power source				
System control	<p>- Monitoring of:</p> <ul style="list-style-type: none"> • The status of mains, battery and load fuses. • Battery presence or absence. • Battery voltage and its operating status. • Mains voltage present in the correct operating range. 			
Battery charge management	<p>- This function is essential for reaching the design life and to ensure optimum operation of the battery.</p> <ul style="list-style-type: none"> • The charge voltages are factory set for «sealed» recombination-type lead acid batteries. • They are consistent with the battery manufacturers' recommendations. • The charger features battery charge current limitation. • The supply of power to the load takes priority over the battery charge. 			
Battery backup	<p>- Automatic disconnection of the charge at end of discharge to preserve its future capacity.</p> <ul style="list-style-type: none"> • Prevents excessively deep discharge that can permanently downgrade performance (cut-off threshold 1.8 V/cell +/- 0.5%). • A report is sent before disconnection. (Pre-cut-off alarm threshold 1.85 V/cell +/- 0.5%). • During autonomous operation, up to the cut-off threshold, the design of the SLAT unit significantly limits the charger's own consumption on the battery. This allows your application to take full advantage of the battery's capacity. 			
> Charger consumption on the battery in autonomous mode				
	75 W	100 W - 150 W	200 W - 300 W	400 W - 600 W
24 V DC	39 mA	75 mA	44 mA	106 mA

> For optimal communication



Displaying and remote reporting of the information

- **Mains:**
 - Presence indicated by a green LED.
 - Remote reporting by dry contact with delay (failsafe).
- **Charger:**
 - Correct operation indicated by a green LED.
 - Charger fault if mains fuse is out of order or not present, or if product is out of order.
 - Remote reporting by dry contact with delay (failsafe).
- **Battery:**
 - Presence indicated by a green LED.
- **Battery fault:**
 - If battery is not present (test every 30 seconds for the 1st 20 minutes after the installation, then every 15 min) or if battery voltage < 1.85 V/cell in autonomous mode.
 - Voltage of less than 1.85 V/cell indicated by flashing orange LED (autonomous mode).
 - Remote reporting by dry contact with delay (failsafe).

On motherboard

- **Internal signaling on the motherboard**
A LED on the motherboard indicates operational status before the cabinet is closed (display board not connected).
Signals:
 - All OK: green
 - Mains fault: orange
 - Battery or charger fault, or load not present: red (this fault takes priority over a mains fault).

> Connection specifications

Screw terminal	75 W	100 W - 150 W	200 W - 300 W	400 W - 600 W
Mains	2.5 mm ²	2.5 mm ²	2.5 mm ²	2.5 mm ²
Batteries	2.5 mm ²	6 mm ²	6 mm ²	10 mm ²
Load (2 outputs)	4 x 2.5 mm ²	1 x 6mm ² 3 x 2.5 mm ²	1 x 6mm ² 3 x 2.5 mm ²	1 x 10mm ² 5 x 2.5 mm ²
Alarm reports*	1.5 mm ²	1.5 mm ²	1.5 mm ²	1.5 mm ²

*the alarm report connector is unpluggable - *Dry contacts, 1 A @ 24 V DC, 0.5 @ 120 V AC.*

> Cabinet characteristics

Version	Size W x H x D (mm)	IP	Base	Cover
C24	322 x 248 x 126	IP30	Metal, RAL 9006	ABS RAL 9003
C48	425 x 345 x 120	IP30	Metal, RAL 9006	Metal, RAL 7035
C180	505 x 610 x 430	IP31	Metal, RAL 7035	Metal, RAL 7035

> Types of battery cabinets

Version	Type	24 V
C24	Wall-mounted	7 Ah, 12 Ah
C48	Wall-mounted	7 Ah, 12 Ah, 24 Ah (4 x 12 Ah)
C180	Floor-mounted	65 Ah, 80 Ah, 120 Ah, 130 Ah, 170 Ah

SLAT can change specifications on his products without prior notice.

YOUR ELECTRICITY SUPPLY MAY DEPEND ON THIS SMALL PIECE OF EQUIPMENT



Electricity grids are set to become even more important in the future, as they are essential elements in the energy transition that Europe has embarked upon. From light vehicles to building heating systems, we're switching from oil to electricity.

If electricity is transported at high voltage to limit losses, we need to transform it to low voltage to use it. This is the role of public transformer substations for low-consumption users, or private substations for large consumers. These MV/LV substations house the **switching and protection equipment**, whose control/command is generally supplied at very low voltage, backed up by a battery. A failure in this small piece of equipment and your entire electrical installation would be cut off!

Energo product range provide **permanent power supply** and back-up for HV substation control systems, in particular control command i.e. power supply for MV cell coils and motorization of low-voltage main circuit breakers. Energo products are renowned for their quality, and provide users with advanced functions such as fault prediction, to avoid any outage.

Compliant with trade standard NF C13-100 April 2015
"Delivery sub-stations fed by HV public distribution network"

Communication via digital display • End-of-life prediction

The ENERGO UPS DC supplies standard and emergency power constantly to the high voltage switchgear, instrumentation and control, supply coils and motorisation of circuit breakers for medium voltage cells and the main low voltage switchboard.







Main functions

- ~ Ensures a continuous supply of power to the equipment.
- ~ Maintains a power reserve for restarting the systems by voluntary action.
- ~ Optimises battery charging and service life.
- ~ Anticipates and informs about the battery's end-of-life.
- ~ Guides operation and maintenance.
- ~ Allows local and remote control.
- ~ Cold start, facilitates commissioning.

Benefits of the ENERGO range

- ~ 2 independent, fuse protected load outputs or 4 circuit breakers distribution.
- ~ Configurable power reserve duration. Wind turbine function.
- ~ Backlit display with plaintext messages.
- ~ Cable inputs on all sides.
- ~ Redundancy box option for live work and high reliability.
- ~ Lithium technology models for outdoor use and renewable energies.

MODEL	WEIGHT (kg)	SIZE W x H x D (mm)	CODE
ENERGO 24V			
ENERGO 24V 6A C85 7Ah	17.2 kg	408 x 408 x 224	3640685007
ENERGO 24V 12A C85 14Ah	23.2 kg	408 x 408 x 224	3641285014
ENERGO 24V 12A C85 24Ah	28.4 kg	408 x 408 x 224	3641285024
ENERGO 24V 12A C85 24Ah 4DJ	28.6 kg	408 x 408 x 224	3641286024
ENERGO 48V			
ENERGO 48V 6A C85 7Ah	22.0 kg	408 x 408 x 224	3680685007
ENERGO 48V 6A C85 14Ah	34.0 kg	408 x 408 x 224	3680685014
ENERGO 48V 12A C85 24Ah	44.9 kg	408 x 408 x 224	3681285024
ENERGO 48V 12A C85 24Ah 4DJ	45.3 kg	408 x 408 x 224	3681286024
ENERGO 48V LITHIUM			
ENERGO 48V 12A C85 LI	27.3 kg	408 x 408 x 224	3681285026
ENERGO 48V RS			
ENERGO 48V 6A C85 7Ah RS	19.6 kg	408 x 408 x 224	3680685407
ENERGO 48V 6A C85 14Ah RS	31.6 kg	408 x 408 x 224	3680685414
ENERGO 48V 12A C85 24Ah RS	49.0 kg	408 x 408 x 224	3681285424
ACCESSORIES			
DES COFFRET TCR C7	1.8	243 x 194 x 97	9189000001
PM ENERGO 150W VRLA MBOARD	1.2 kg	-	3605010705
PM ENERGO 300W 24V VRLA MBOARD	1.2 kg	-	3605110705
PM ENERGO 300W 48V VRLA MBOARD	1.2 kg	-	3685110705
PM ENERGO 600W VRLA MBOARD	2.0 kg	-	3605210705
			3605210703

> Ratings		
24 V DC	6 A (50 A at peak)	12 A (50 A at peak)
48 V DC*		
The currents I_n shown are at rated output power.		
*The Lithium model is only available in 48 V DC.		
> Standard -based specifications		
Safety	• EN IEC 62368-1 (2020) + A11 (2020)	
EMC - Immunity	• EN IEC 61000-6-2 (2019)	
EMC - Emission	• EN IEC 61000-6-4 (2019) • EN IEC 61000-3-2 (2019) • EN 55032 • EN 55024	
Trade	• NFC 13-100 compliant	
Environment	This product range meets the environmental requirements of ISO 14001, RoHS and WEEE standards.    	
> Environmental specifications		
Humidity	during storage: relative humidity of 10% to 95% non-condensing in operation: relative humidity of 20% to 95% non-condensing	
Storage temperature	-25°C to +85°C	
Operating temperature	75% of load	-5°C to +50°C
	100% of load	-5°C to +40°C
Altitude	Above 2,000 m, the maximum temperature is lowered by 5% every 1,000 m	
MTBF	100,000 h (with battery Lithium) and 200,000 h (without battery) at 25 °C product external environment, rated mains voltage, 75% load	
> Input characteristics		
Voltage	99 to 264 V AC	
Frequency	45 to 65 Hz	
Neutral system	TT - TN - IT	
Inrush current	limited by NTC	
Upstream circuit breaker required	D Curve	
Class	Class 1	
	Charger 300 W	Charger 600 W
Mains consumption @ 99 V	4 A	8 A
Mains consumption @ 264 V	2 A	4 A
> Efficiency		
At 20% load	84%	
At nominal load	90%	
> Output characteristics		
Nominal voltage	24 V DC	48 V DC
Floating voltage (U_n) adjusted to half load and 25°C	27.2 V +/-0.5%	54.4 V +/-0.5%
Charger current limitation	I_n : 6 A to 12 A depending on model	
> Charger consumption on battery in stand-alone mode		
	24 V DC	48 V DC
300 W	94 mA	37 mA
600 W	106 mA	73 mA

> For reliable output voltage							
Protection from external aggressions	<ul style="list-style-type: none"> - Resistance to all types of external aggression: <ul style="list-style-type: none"> • Overvoltages encountered in the mains grid (lightning, industrial, isolation fault on impedant neutral, etc.) • Short-circuit on primary by slow-blow timed fuse on phase. • Differential mode shock waves by varistor and fuse. • Battery polarity reversals. • Overvoltages on secondary. • Overcurrents and short circuits on secondary. • Short circuits inside the product by primary fuse. • Rises in external temperatures (outside specified range). 						
Charger current limitation management	<ul style="list-style-type: none"> - The output current limitation can start a charging cycle on a discharged battery. • Protects the product completely from short-circuits on the installation. • Protection selectivity is provided by fuses on each load output and the battery circuit. 						
Control and high-performance filtering	<ul style="list-style-type: none"> - Particularly efficient output voltage regulation <ul style="list-style-type: none"> • Static control < 0.5% of U_n. • Dynamic control < 5% of U_n for cumulative variations of the mains and the load (10% to 90%). - Boosted filtering that eliminates all interference and reduces the ripple on the DC output voltage. Battery capacity preserved and guaranteed optimum operation of systems. <ul style="list-style-type: none"> • LF rms ripple < 0.5% of U_n. • HF ripple (20 MHz-50 Ω) < 4% of U_n. 						
> For the control and management of the emergency power source							
LED Test function	The two LED light up for one second when the power is switched on.						
System control	<ul style="list-style-type: none"> - Monitoring: <ul style="list-style-type: none"> • State of mains, battery and load fuses. • Presence or absence of battery. • Temperature inside the cabinet. • Battery voltage. • Operating status. • Presence of mains voltage in the correct operating range. 						
Battery charge management	<ul style="list-style-type: none"> - This function is essential to achieve the theoretical service life and guarantee optimum battery operation. <ul style="list-style-type: none"> • The charge voltages are factory set. • They comply with the stipulations of the battery manufacturers. • The charger incorporates battery charge current limitation. 						
Battery safeguard	<ul style="list-style-type: none"> - Charger disconnects automatically at the end of battery discharge to preserve battery life. Prevents batteries from becoming too discharged, which would cause irreparable deterioration in performances (cut-off threshold 1.8 V/cell at +/-0.5%). 						
Battery Circuit Test function	Every thirty seconds for the first twenty minutes, then every fifteen minutes.						
Battery Health Test function	Impedance test performed every sixteen hours (internal resistance measurement).						
Temperature compensation	-3 mV/cell/°C (on lead battery models only)						
Restart (C13-100)	By local or remote manual action. After a configurable back-up time, the load will be disconnected from the battery. The restart button blinks and indicates a restart stand-by. "Restart?", "Restart in progress" or "Restart impossible" is displayed.						
Cold start	Start up without the mains present, only using the battery						
Configurable back-up time	Via LCD screen (30 min, 1 h, 2 h, 4 h, 8h, 12h, no limit).						
Wind turbine function	Delays the remote restart. The execution of the order can be delayed from 1 to 30 s, configurable via the LCD screen.						
> For optimum communication							
- LEDs for status display and control							
LED restart button	ENERGO awaiting restart						
	Steady green	Flashing green	Steady yellow	Flashing yellow	Fast flashing yellow	Steady red	Off
Battery LED	Battery charged	Battery charging	Battery operation	- Low battery - End of autonomy (SoC)*	Lifespan Default (SoH)*	Battery test fault	Battery disconnected in restart stand-by
User LED	Load powered	-	-	-	-	- Charger fault - Fuse fault	Load disconnected
* present on ENERGO RS							

> For optimum communication

- Digital display

Display and remote reporting of information	<p>The product displays the standard menu constantly. The standard menu display is incremented every ten seconds to indicate the next item of information and runs on a loop. Pressing and holding (1 s) is used to access the configuration menu. Pressing and holding again once in the configuration menu gives access to one of the proposed sub-menus. Press and hold to select a variable in one of the sub-menus. When selected, variable has an * next to it.</p> <p>Two menus:</p> <ul style="list-style-type: none"> - The Standard Menu displays the information regarding <ul style="list-style-type: none"> • the battery voltage and current, • the output voltage and current • the mains, charger, battery or fuse fault • the remaining autonomy (lead model) • the end-of-life and replacement of the battery - The Configuration Menu allows to select <ul style="list-style-type: none"> • the language (Lead model: French/English/German; Lithium model: French/English) • the duration of the autonomy (Lead model: 0.5h/1h/2h/4h/8h/12h/no limit; Lithium model: 0.5h/1h/2h/4h) • the restart delay (0 to 30s) • the battery type (lead model) • to do a battery test (lithium model)
---	--

- Remote reporting and restart

	ENERGO		ENERGO RS	
Terminals				
1-2	General fault (charger fault, battery, impedance)	Positive safety dry contact	General fault (charger fault, battery, impedance, mains)	Positive safety dry contact
3-4	Présence secteur	Positive safety dry contact	End of battery life alarm	Positive safety dry contact
5-6	End of battery life alarm	Positive safety dry contact	RS485 Communication	Liaison série
7-8	Restart	Relance à distance	Restart	Relance à distance

> Connection specifications

Screw-type terminal block	
Mains	max. 4 mm ²
Batteries	Cabling supplied
Load (two outputs)	max 10 mm ²
Alarm reporting	max 2.5 mm ²

> Cabinet characteristics

	Cabinet dimensions W x H x D (mm)	Weight (kg)	IP	Cabinet	Type
C85 Lead	408 x 408 x 224	16 - 50	IP31	Metal RAL 7035	Wall or floor-mounted
C85 Lithium		27			

> Cabinet incorporating batteries

	24 V	48 V
C85 Lead	7 Ah, 14 Ah, 24 Ah	
C85 Lithium	-	26 Ah

> Accessories and spare parts

DES COFFRET TCR C7	Redundancy box
PM ENERGO DISPLAY	Display unit
PM ENERGO MBOARD	Power board

SLAT reserves the right to alter the characteristics of its products without prior notice.

ENERGO LITHIUM, A REAL BENEFIT FOR YOUR RENEWABLE ENERGY INSTALLATIONS



Renewable energies are developing rapidly to meet our need for carbon-free energy. **Solar fields and wind farms** are generally installed on isolated sites, to ensure greater acceptance by local residents.

Energo products respond to this constraint thanks to their remote control capability. In addition, Energo products feature exclusive, patented functions to **monitor** equipment and **predict future fault**. This enables you to program your preventive maintenance operations and avoid breakdowns synonymous with lost production and emergency repairs.

SLAT has been designing **lithium batteries** for a number of years, mastering the entire manufacturing chain. With **a lifespan at least 3 times longer** than that of lead batteries, you can avoid frequent travels to your site for battery replacement. Our lithium batteries are particularly robust, easily withstanding both high and low temperatures in non-air-conditioned premises.

With very low self-discharges, they can also **withstand weeks without power** after their autonomy. An invaluable advantage for isolated sites or long periods without wind. And it's always possible to manoeuvre even at low battery charge, a unique feature of SLAT lithium batteries.

Energo Lithium is the ideal product for Renewable Energy sites.

THE ADVANTAGES OF LFP LITHIUM TECHNOLOGY MORE THAN JUSTIFY ITS PREMIUM POSITIONING!



In the security and safety sector, reliability and continuity of service are essential for installations on which human lives depend, or where the assets being protected are important. Therefore SLAT products feature either lead-acid or lithium-acid batteries. Of all storage systems, lithium LFP (lithium-iron-phosphate) offers **the best safety features**.

LFP battery advantages over lead-acid or Li-ion batteries:

- 3 times smaller and 3 times lighter than a lead-acid battery of equivalent capacity
- Lifespan in excess of 10 years, 3 times longer than lead and Li-ion batteries
- LFP batteries do not present risk of thermal runaway, fire, explosion or flaring that characterize Li-ion technology.
- 1800 total charge/discharge cycles, and way more for partial discharges, making it the ideal battery for applications with regularly recurring shutdowns, unlike Li-ion whose number of cycles is less than 1000.
- Resistance to extreme positive and negative temperatures, suitable for products installed outdoors.
- Low self-discharge: LFP batteries can withstand 9 months' storage before needing recharge.

ESSENTIAL PROTECTION TO ENHANCE THE OPERATION OF ELECTRONIC EQUIPMENT

Even when our power grids are reliable, **electrical disturbances** persist and can interfere with the operation of electronic equipment. These disturbances can be caused by weather phenomena or static discharges. But most are simply the consequences of normal installation operation, such as opening a circuit breaker or starting a motor.

To protect the network and maintain the energy supply, switching devices open some meshes and close others. These operations are automatic and frequent on a healthy network. They do, however, generate interruptions ranging from a few hundred milliseconds to a few seconds.

SLAT power supplies with Supercaps are **totally free from these electrical disturbances**, and deliver **clean current** without any micro-cuts..

Advantages of SLAT products with Supercaps

- Protects PLCs from power grid disturbances
- Highly recommended for MESH radio networks
- Protects against data loss in IP transmissions
- Prevents false alarm feedback
- Improves system lifetime

Supercaps features

- Autonomy: minimum 3 seconds
 - Time required to reset a mains circuit-breaker
 - Absorbs micro-interruptions, voltage variations, etc.
 - Filters out electromagnetic interference
- Lighter than lead or lithium batteries
- Can be stored for years before recharging
- Virtually unlimited number of charge-discharge cycles

GET THE SMART CITY SIMPLY CONNECTED



The connected objects in urban areas are deployed everywhere to give the municipalities the means to manage more efficiently things like traffic movement, communication, waste evacuation, urban pollution, street lighting, incivility, car parks, and illegal posting ... In this way, urban areas are moving at high speed to offer their residents better daily comfort and more efficiency in public services.

All these services are based on information resources located at hotspots that transmit the data to be processed in return for action on the ground. SLAT provides **power supplies for and interfaces** to the electrical and internet networks that simplify the installation and operation of connected objects in urban areas.



SELECTION GUIDE

	EPV VIEW	EPV 2LIFE	EPV4 / EPV5	SYNAPS IP	SYNAPS PoE 2 / PoE 4	SYNAPS PoE 5 / PoE 6	SYNAPS PoE 8	SOC-M IP	SOC-PoE 8
Installation	Outdoor	Outdoor	Outdoor	Outdoor	Outdoor	Outdoor	Outdoor	Indoor	Indoor
Application	Intermittent mains	Intermittent mains	Intermittent mains	Permanent mains	Permanent mains	Permanent mains	Permanent mains	Permanent mains	Permanent mains
Brown-out protection only	-	-	-	Yes	Yes	-	-	-	-
Brown-out protection with autonomy (full load)	16 h	16 h	20 h	39 min	39 min	22 min	14 min	19 min / 1h19	14 min
Power	100 W	100 W	120 W	55 W	55 W	150 W	180 W	55 W	180 W
DC output voltage	12 V DC ou 24 V DC	12 V DC ou 24 V DC	12 V/24 V DC 24 V AC ¹	12 V / 24 V	55 V / 12 V ² / 24 V ²	12 V / 24 V	-	12 V / 24 V	-
Ethernet ports	2	2	-	2	1	1 or 2	-	2	-
PoE/PoE+ ports	x ¹	x ¹	5 / 6	x ²	2 or 4	4	8	-	8
HiPoE ports	x ¹	x ¹	2	x ²	-	2	4	-	4
12 V/24 V PoE ports	x ¹	x ¹	1 / 2	x ²	x ²	2	x ²	-	-
Fiber ports	-	-	1 / 2	x ²	x ²	2	2	-	2
SNMP	v1	v1	v1, v2c, v3	v1, v2c, v3	v1, v2c, v3	v1, v2c, v3	v1, v2c, v3	v1, v2c, v3	v1, v2c, v3
BACnet	-	-	-	IP	IP	-	IP	IP	IP
Modbus	-	-	-	-	-	-	-	-	-
Switch	x ¹	x ¹	managed	-	unmanaged	managed	managed	-	managed
Page	67	69	74 and 79	81	85	89	94	108	120

¹ with option

² ask for our customized Synaps offer page 96



THE WIRING SOLUTION FOR ANY ENVIRONMENT

Your project : Installation of video protection equipment, signage, sensors, etc. in your town or city

Your need : Connect your equipment to the 230V power supply and transmit your data over the Ethernet network. The SYNAPS and EPVIDEO ranges provide all the wiring connections and conversions you need.

Choose the product that best suits your situation:

The EPVIDEO solution

- You have an intermittent 230VAC power supply: daily power cuts or voltage drops
- You need several hours of autonomy on your DC equipment

The SYNAPS solution

- You have a permanent mains
- You want to filter out micro outages and/or blackouts lasting from a few minutes to several hours

The EPVIDEO solution

(pages 66 to 77)

The SYNAPS solution

(pages 78 to 96)



EPVIDEO - Your city finds its solution

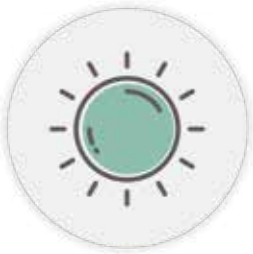

SUN SHIELD

- ~ Intense exposition to the sun
- ~ High day temperatures
- ~ Especially designed for southern cities



NIGHT OUT

- ~ Public lighting switched off at night
- ~ Maintains security 24 hours a day
- ~ Compatible with energy-saving systems

SOLAR

- ~ Use of solar energy in hybrid mode
- ~ Reduced energy consumption
- ~ Specially designed for the ecological transition



EXTREME COLD

- ~ Low outdoor temperatures (down to -40°C)
- ~ Guaranteed start-up and operation
- ~ Specially designed for northern countries and high-altitude ski resorts



A safe solution tailored to your needs

- ~ Fully configurable, made to order to fit in perfectly with your system: you optimise your solution.
- ~ Factory-wired and tested, ready to install and connect: You only need to place one order.
- ~ CE marking for your product, Certificate of Associativity for your system: You get the guarantee and security of a solution that works.

EPVIDEO EPV VIEW



Permanent power supply on street lighting

PoE/PoE+/HiPoE (IEEE 802.3af/at/bt)

OUTDOOR



Reliable power supply and active protection in all circumstances

The EPV VIEW range enables the quick deployment of video protection systems or other Smart City equipment. Particularly well-suited to installations consisting of a camera and a transmission system, it creates a reliable, long-lasting solution. It uses the existing street lighting infrastructure to ensure a 24/7 power supply.



EPV VIEW
210 x 721 x 130 mm

Main functions

- ~ Power your equipment with PoE up to 60 W
- ~ Power your antennas with 12 V or 24 V PoE
- ~ Supplies up to 100 W
- ~ Configurable voltage: 12 V DC or 24 V DC
- ~ 10 kA lightning surge arrester
- ~ Full outdoor enclosure: IP66, IK10
- ~ Vandal-proof: IK10 impact resistance and cable protection housing

The advantages of the EPV VIEW range

- ~ Transmits data and images to your supervisor
- ~ Protects against lightning strikes and electromagnetic interference
- ~ Ensures the operation 24/7
- ~ Easy installation thanks to quick connectors and door
- ~ Designed for outdoor use with waterproof, vandal-proof enclosure
- ~ Lithium battery SLAT with 10 year service life

*Manufacturer's extended warranty available, contact us for details.

MODEL	WEIGHT (kg)	SIZE W x H x D (mm)	CODE
EPV-V 5K M 2P	13.1 kg	210 x 721 x 130	4621809201
EPV-V 5R M 2P	17.1 kg	210 x 721 x 130	4643809201
EPV-V 5S M 2P	17.1 kg	210 x 721 x 130	4646809201
MAINTENANCE PACK			
EPV-V 5K PACK	7.3 kg	530 x 152 x 230	4621109201
EPV-V 5R PACK	11.3 kg	530 x 152 x 230	4643109201
EPV-V 5S PACK	11.3 kg	530 x 152 x 230	4646109201
ACCESSORIES			
A KIT 24V AC	0.6 kg	-	4690007000
A KIT SWITCH 5 PORTS EPV	0.3 kg	-	4690009999
A SUN SHIELD EPV PM	0.9 kg	252 x 732 x 140	4690730201

EPVIDEO EPV 2LIFE



Secure 24/7 power supply - Videoprotection

REFURBISHED EQUIPMENT

OUTDOOR



Active video protection in all circumstances

The EPV 2LIFE range enables the quick deployment of a video protection camera on street lighting. Part of the circular economy, this range incorporates refurbished components guaranteed by the manufacturer. The manufacturer's certificate of associativity ensures the service continuity for the associated equipment for many years to come.



EPV 2LIFE
210 x 721 x 130 mm

Main functions

- ~ Power your equipment with PoE up to 60 W
- ~ Power your antennas with 12 V or 24 V PoE
- ~ Supplies up to 100 W
- ~ Configurable voltage: 12 V DC or 24 V DC
- ~ 10 kA lightning surge arrester
- ~ Full outdoor enclosure: IP66
- ~ Vandal-proof: IK10 impact resistance and cable protection housing

The advantages of the EPV 2LIFE range

- ~ Certificate of associativity, guaranteeing your equipment's functioning for many years to come
- ~ Active parts refurbished by the manufacturer
- ~ Long life Lithium LFP battery pack
- ~ 2-year total warranty
- ~ Low carbon impact product
- ~ Eligible for tenders with a clause against waste of resources

*Manufacturer's extended warranty available, contact us for details.

MODEL	WEIGHT (kg)	SIZE W x H x D (mm)	CODE
EPV-2L 5L M 2P	17.1 kg	210 x 721 x 130	4825601003
EPV-2L 5R M 2P	17.1 kg	210 x 721 x 130	4841601003
MAINTENANCE PACK			
EPV-2L 5L PACK	11.3 kg	530 x 152 x 230	4825109201
EPV-2L 5R PACK	11.3 kg	530 x 152 x 230	4843109201
ACCESSORIES			
A KIT 24V AC	0.6 kg	-	4690007000
A KIT SWITCH 5 PORTS EPV	0.3 kg	-	4690009999
A SUN SHIELD EPV PM	0.9 kg	252 x 732 x 140	4690730201

> Mechanical characteristics							
Boxes	EPV version	Size W x H x D (mm)			Materials	Protection rating	CdA
Cabinet 	EPV-V 5K M 2P EPV-V 5R M 2P EPV-V 5S M 2P EPV-2L 5L M 2P EPV-2L 5R M 2P	cabinet only : 210 x 629* x 130 with vandal-proof cover : 210 x 721 x 130			Aluminum	IP66 / IK10	0.301
Cabinet with SUN SHIELD casing	EPV + vandal-proof cover + A SUN SHIELD EPV PM	248 x 721 x 160			Aluminum	IP66 / IK10	0.350
* including cable gland height: 33 mm							
Weight (kg)	EPV-V 5K M 2P	EPV-V 5R M 2P	EPV-V 5S M 2P	EPV-2L 5R M 2P	EPV-2L 5L M 2P	A SUN SHIELD EPV PM	
	13.1 kg	17.1 kg	17.1 kg	17.1 kg	17.1 kg	0.91 kg	
Installation	Wall, post or pull box mounting Pack to be installed once the cabinet is mounted on the support Plug and play product						
Thermal management	Aluminium with fins: Optimised heat exchange surface Uniform heat distribution over the entire surface when required: No hot spots						
Camera installation	Removable cable cover plate for the mounting of a dome camera with a maximum diameter of 190 mm and a maximum weight of 4 kg (camera not included). Holes must be drilled as required.						
> Electrical input characteristics							
AC network voltage	175 V to 265 V AC single-phase						
Frequency	45 Hz to 65 Hz						
Class	1						
Inrush current	limited to 12 A						
Neutral system	TT, TN						
Primary current	1 A						
Upstream circuit breaker to be provided	D curve						
Lightning arrester	Type 2 / 10 kA						
> Electrical output characteristics							
PoE							
PoE port	1 PoE/PoE+/HiPoE port						
PoE/PoE+	IEEE 802.3af/at - 15 W / 30 W per port; Mode B						
HiPoE	IEEE 802.3bt - 15 W / 30 W / 60 W per port; power supply over 4 PoE pairs (4PPoE)						
Passive PoE port	1 passive PoE port: 12 V PoE or 24 V PoE (according to the DC output)						
Operating output							
DC output	12 V DC or 24 V DC						
Current limitation	12 V DC : In = 5 A, U > 50% Un 24 V DC : In = 4 A, U > 50% Un						
Output voltage regulation	≤ 0.5%						
LF ripple	12 V DC: 10 mV effective at In 24 V DC: 30 mV effective at In						
Max. available power at DC output	12 V DC : 60 W 24 V DC : 96 W						

Power					
	EPV-V 5K M 2P	EPV-V 5R M 2P	EPV-V 5S M 2P	EPV-2L 5L M 2P	EPV-2L 5R M 2P
Maximum power	100 W	100 W	100 W	100 W	100 W
Average power	40 W for 8h 20 W for 16h of autonomy	80 W for 8h 40 W for 16h of autonomy	95 W for 8h 47 W for 16h of autonomy	63 W for 8h 31 W for 16h of autonomy	80 W for 8h 40 W for 16h of autonomy
	Power to be validated by the associativity certificate				
Charging time on grid	To be validated by the associativity certificate				

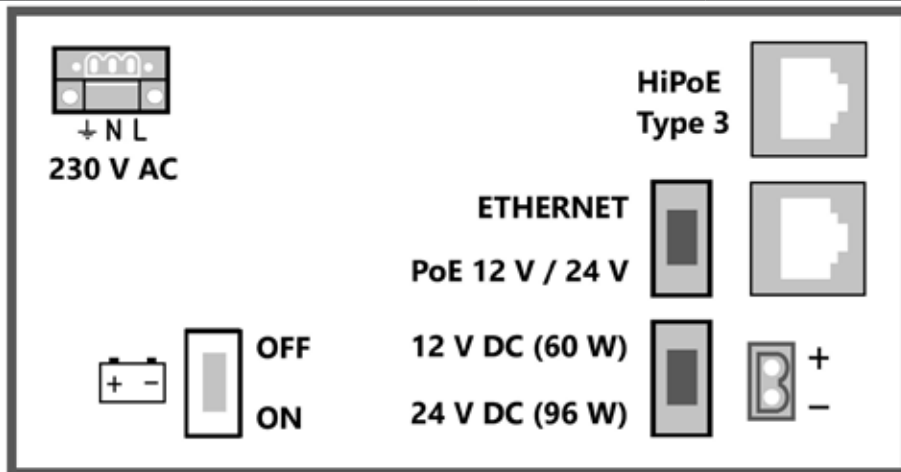

Connections	
Mains	3 (2+PE) Screw terminals on the lightning arrester (230 V AC power supply) 3-point connector for connecting the arrester to the pack
PoE/PoE+/HiPoE port	1 RJ45 ports (100 Mbps) : Ethernet cable Category 5 or more, shielded
Passive PoE port	1 RJ45 ports (100 Mbps) : Ethernet cable Category 5 or more, shielded
DC Output	1 DC output: Screw terminal with plug-in connector with polarizing slot
Cable cross-section	Mains: max 4 mm ² DC Output: max 2.5 mm ²
Cable feedthrough	Via 4 watertight cable glands
> Functional characteristics	
Intelligent start	Soft-start of the charging cycle (function active if T < 0°C).
Intelligent Healthguard	Limits the amount of energy discharged to safeguard the battery and ensure its lifespan.
Network filtering	Filters out power grid disturbances.
Cooling	Via aluminium radiator. Intermittent fan assistance (240 W version).
Protections	
Against atmospheric or industrial overvoltage on primary (10 kA lightning arrester).	
Against too high currents on the auxiliary output.	
Against overcurrent and short circuits on the output by disconnecting the ports.	
> Battery	
Latest generation Lithium-ion LiFePO4 Technology (no risk of thermal runaway).	
Lead-free, cadmium-free, 100% recyclable.	
Storage: 9 months without recharging.	
10 year service life.	
Advanced management settings, cell balancing, overcurrent and overvoltage protection.	
> Signaling	
1 LED indicates the operation of the lightning arrester	

> Environmental specifications		
Temperature		
Storage	0°C ... +40°C	
Operating	in charge mode mains present	-10°C ... +50°C
	in discharge mode mains absent	-10°C ... +50°C with derating
Derating	Above -5°C the capacity is maximum; between -5°C and -10°C the capacity drops by 5%.	
Temperatures apply for start-up and operation.		
Solar radiation - A SUN SHIELD EPV PM		
Protection	The sunshade provides protection against solar radiation	
Altitude		
Above 2,000 m, the temperature decreases by 5% every 1,000 m		
Humidity		
0 to 100 % condensing		
MTBF		
100,000 h (with battery) and 200,000 h (without battery) at 25 °C product external environment, rated mains voltage, 75% load		
> Standards		
IEEE Standards		
IEEE 802.3af	PoE	
IEEE 802.3at	PoE+	
IEEE 802.3bt	HiPoE (type 1 à 3)	
Electrical and safety standards		
Safety	• EN IEC 62368-1 (2020) + A11 (2020) • EN IEC 62368-3 (2020)	
EMC - Immunity	• EN IEC 61000-6-1 (2019) • EN IEC 61000-6-2 (2019)	
EMC - Emissions	• EN IEC 61000-6-3 (2021) • EN IEC 61000-6-4 (2019)	
	• EN IEC 61000-3-2 (2019)	
	• EN 55032 (2015) (class A)	
   		
Other standards		
Solar radiation	• EN IEC 60068-2-5 (2018)	
Transport approval	• UN 38.3	
> Accessories		
PACK	Spare pack	
A KIT 24V AC	Kit for a 24 V AC power supply	
A KIT SWITCH 5 PORTS EPV	5-port switch	
A SUN SHIELD EPV PM	Product casing; protects the box Casing for painting in street furniture colors Sunshade	

*SLAT reserves the right to modify the characteristics of its products without prior notice.

EPVIDEO EPV4



Power supply on public lighting for a permanent video protection

PoE/PoE+/HiPoE (IEEE 802.3af/at/bt)



OUTDOOR

An uninterrupted video protection on an intermittent network

The EPVIDEO range allows to quickly deploy reliable and durable video protection systems, using existing public lighting infrastructures. It ensures a 24/7 power supply and continuity of service for the equipment in case of power failure.



EPV4
278 x 751 x 269 mm



EPV4 SUN SHIELD
299 x 888 x 291 mm

Built-in functions





- ~ Power your equipment with PoE up to 90 W
- ~ Managed 5-port layer 2 switch
- ~ Secure webserver and SNMP link
- ~ A fiber link for a remote connection
- ~ Supplies up to 240 W in Power Over Ethernet
- ~ Configurable auxiliary voltage : 12 V DC or 24 V DC
- ~ Configurable automatic reboot on each port
- ~ 10 kA lightning arrester for lightning strikes

The advantages of the EPV4 range

- ~ Transmits the data up to 20 km by optical fiber
- ~ Protects against lightning and electromagnetic interferences
- ~ Manages the video flows thanks to its multiple dedicated functions
- ~ Ensures the operation 24/7
- ~ Provides a space for customer equipment
- ~ Simplified installation thanks to its door & the assembly on the pole
- ~ Designed for outdoor use with a waterproof, vandalproof box
- ~ Lithium battery SLAT with 10 year service life

* Manufacturer's extended warranty available, contact us for details.

MODEL	WEIGHT (kg)	SIZE W x H x D (mm)	CODE
EPV4			
EPV4 5N G 4P1C	14.9	278 x 751 x 269	4631708004
EPV4 5Q G 4P1C	17.5	278 x 751 x 269	4641708004
EPV4 5T G 4P1C	20.2	278 x 751 x 269	4651708004
EPV4 SUN SHIELD	18.5	299 x 888 x 291	4641708101
EPV4 NIGHT OUT	20.8	278 x 751 x 269	4652708102
EPV4 EXTREME COLD	20.8	278 x 751 x 269	4652708103
EPV4 SOLAR	17.5 + 7.1	278 x 751 x 269	4641708104
ACCESSORIES			
A KIT POE PASSIF	0.04	-	4690004000

> Mechanical characteristics							
Boxes	EPV versions	Size W x H x D (mm)	Available customer space (min) W x H x D (mm)	Materials	Protection rating	CdA	
Cabinet 	EPV4 5N G 4P1C EPV4 5Q G 4P1C EPV4 5T G 4P1C EPV4 NIGHT OUT EPV4 EXTREME COLD EPV4 SOLAR	278 x 751 x 269*	 208 x 170 x 106	Aluminum ABS/PC	IP65 / IK10	0.251	
Cabinet with sunshade 	EPV4 SUN SHIELD	299 x 888 x 291*	 208 x 170 x 106	Aluminum ABS/PC ABS PMMA	IP65 / IK10	0.319	
Solar panel	EPV4 SOLAR	640 x 550 x 35	-	-	IP65	0.156 (30° angle)	
* D with mounting brackets: + 2 mm							
Weight (kg)	EPV4 5N G 4P1C	EPV4 5Q G 4P1C	EPV4 5T G 4P1C	EPV4 SUN SHIELD	EPV4 NIGHT OUT	EPV4 EXTREME COLD	EPV4 SOLAR
	14.9 kg	17.5 kg	20.2 kg	18.5 kg	20.8 kg	20.8 kg	17.2 kg + 7.1 kg
Installation	Wall or post mounting Battery to be installed once the cabinet is mounted on the support Plug and play product						
Thermal management	Aluminium with fins: Optimised heat exchange surface Uniform heat distribution over the entire surface when required: No hot spots						
Camera installation	Removable cable cover plate for the mounting of a dome camera with a maximum diameter of 190 mm and a maximum weight of 4 kg (camera not included). Holes must be drilled as required.						
> Electrical input characteristics							
AC network voltage	175 V to 265 V AC single-phase						
Frequency	45 Hz to 65 Hz						
Class	1						
Inrush current	25 A, limited by NTC (120 W) 45 A, limited by NTC (240 W)						
Neutral system	TT, TN						
Protection against	primary short-circuit and differential mode shock waves						
Primary current @ 175 V AC	1.3 A (120 W) ; 2.6 A (240 W)						
Primary current @ 265 V AC	0.7 A (120 W) ; 1.4 A (240 W)						
Upstream circuit breaker to be provided	D curve						
Lightning arrestor	Type 2 / 10 kA						
> Electrical output characteristics							
PoE							
PoE ports	5 PoE/PoE+/passive PoE ports including 2 HiPoE ports						
PoE/PoE+	IEEE 802.3af/at - 15 W / 30 W per port; Mode B						
HiPoE	IEEE 802.3bt - 15 W / 30 W / 60 W / 90 W per port; power supply over 4 PoE pairs (4PPoE)						
Passive PoE	55 V PoE: all PoE ports, 30 W* operating. 12 V PoE / 24 V PoE: Combo port , 1 A* operating. * Max. 400 mA at startup.						
Operating output							
DC output	12 V DC or 24 V DC						
Current limitation	12 V DC : In = 7.2 A, U > 50% Un 24 V DC : In = 4.4 A, U > 50% Un						
Output voltage regulation	≤ 1%						
LF ripple	<5 mV effective at In						
Max. available power at DC output	12 V DC : 60 W 24 V DC : 96 W						

Power						
	EPV4 5N G 4P1C	EPV4 5Q G 4P1C	EPV4 5T G 4P1C	EPV4 SUN SHIELD EPV4 SOLAR	EPV4 NIGHT OUT	EPV4 EXTREME COLD
Maximum power	120 W	120 W	120 W	120 W	240 W	240 W
Average power	49 W for 8h 23 W for 16h of autonomy	83 W for 8h 40 W for 16h of autonomy	103 W for 8h 52 W for 16h of autonomy	83 W for 8h 40 W for 16h of autonomy	69 W for 10h 53 W for 6h 39 W for 3h of public lighting	124 W for 8h 60 W for 16h of autonomie
	Power to be validated by the associativity certificate					
Charging time on grid	To be validated by the associativity certificate					
EPV4 SOLAR	Hybrid power supply over solar panel					
Connections						
Mains	3 (2+PE) Screw terminals on the lightning arrester (230 V AC power supply)					
PoE/PoE+/HiPoE ports	4 RJ45 ports (100 Mbps) : Ethernet cable Category 5 or more, shielded, straight or twisted cables					
Combo ports	1 Combo port: or	RJ45 port: Ethernet cable Category 5e or more, shielded, straight or twisted cables (1 Gbps)				
		SFP port: SFP module 1 Gbps transceiver				
DC Output	1 DC output: Screw terminal with plug-in connector with polarizing slot					
Digital Input	Screw terminal with plug-in connector with polarizing slot (1 input)					
Dry Contact	Screw terminal with plug-in connector with polarizing slot (open collector: 50 mA @ 60 V DC)					
Cable cross-section	Max. 2,5 mm ² (Mains, digital input and dry contact)					
Cable feedthrough	Via 10 watertight cable glands					
> Functional characteristics						
Intelligent start	Soft-start of the charging cycle (function active if T < 0°C).					
Intelligent Healthguard	Limits the amount of energy discharged to safeguard the battery and ensure its lifespan.					
Capacity reserve	Maintains the battery performance in very cold weather and compensates for natural battery ageing.					
Restart function	Allows manual remote control of the on/off function per PoE port / DC output.					
DAM function	Allows the monitoring of the connected products with an automatic reboot in the event of a fault. Configurable per port.					
Network filtering	Filters out power grid disturbances.					
Cooling	Via aluminium radiator. Intermittent fan assistance (240 W version).					
Autonometer	Informs of the percentage of the remaining autonomy.					
Protections						
Against atmospheric or industrial overvoltage on primary (10 kA lightning arrester).						
Against too high currents on the auxiliary output (50 mA).						
Against overcurrent and short circuits on the output by disconnecting the PoE port.						
> Battery						
Latest generation Lithium-ion LiFePO4 Technology (no risk of thermal runaway).						
Lead-free, cadmium-free, 100% recyclable.						
Storage: 9 months without recharging.						
10 year service life.						
Advanced management settings, cell balancing, overcurrent and overvoltage protection.						
> Signaling						
5 LEDs indicate the PoE activity on the corresponding port						
5 LEDs indicate the data transmission activity on the corresponding port						
1 LED indicates the operation of the lightning arrester						

> Switch properties		
Switch	Layer 2	
Queues per port	4	
Max. number of VLANs	4094	
VLAN ID range	VID 1 to 4094	
Max. number of IGMP groups (multicast)	1024	
Number of MAC addresses	Up to 8000 MAC addresses	
Max. length Jumbo Frame	10 kB	
Packet buffer memory	1 Mbit	
Communication		
Communication speed	PoE ports	10 / 100 Mbps
	Combo port	100 / 1000 Mbps
Application layer protocols	HTTP, HTTPS, SNMP (v1, v2c, v3),	
Network layer protocols	IPv4, ICMP, DNS	
Management (Web, SNMP)		
Web GUI interface / Web server	Built-in switch configuration utility for browser-based device configuration (HTTPS). Supports configuration, system dashboard, maintenance and monitoring; Visualisation of the operating states	
IP address	Specific to each EPV	
Firmware update	Upgrade via web browser (HTTPS)	
SNMP	SNMP v1, v2c, v3	
Alarm management	SNMP trap sending	
> Switching characteristics		
The configuration of the switch functions is done via the embedded website.		
Switch Layer 2		
VLAN	Supports up to 4K VLANs simultaneously (out of 4094 VLAN IDs); Port-based VLAN; 802.1Q tag-based VLAN	
IGMP v1/v2 Snooping	IGMP limits bandwidth-intensive multicast traffic to only the requesters; it supports 1024 multicast groups (source-specific multicasting is also supported)	
Uplink	Uplink mode limits the sending of multicast traffic on the combo port	
Log/SysLog	Records events locally and sends them to one or two specific servers	
NTP	Allows the switch clock to be synchronised with the network clock	
Security		
Website	HTTPS (HTTP operation possible) Management administrator account vs. user account	
HTTPS	Authentication and encryption with a root certificate (CA) Allows secure access to the switch management webserver	
SNMP	SNMP V3 with data encryption	
Protocol for securing exchanges	TLS (Transport Layer Security, versions 1.0 to 1.3) SSL not supported (banned by RFC 7568)	
Quality of Service		
Hardware Priority Queue	Supports 4 hardware queues	
Scheduling	Strict priority and weighted round-robin (WRR)	
	Queue assignment based on DSCP and class of service (802.1p/ CoS)	
Classification	Port based; 802.1p VLAN priority based; IPv4 precedence/ type of service (ToS) / DSCP based	
Green Ethernet		
Link detection	Compliant IEEE802.3az Energy Efficient Ethernet Task Force. Automatically turns off power on Gigabit Ethernet RJ45 port when detecting link down or Idle of client. Active mode is resumed without loss of any packets when the switch detects the link up.	
Cable length detection	Adjusts the signal strength based on the cable length. Reduces the power consumption for shorter cables.	
Eco Mode	Shifts automatically to power-saving mode.	

> Environmental specifications				
Temperature				
		EPV4 5N G 4P1C, EPV4 5Q G 4P1C, EPV4 5T G 4P1C EPV4 NIGHT OUT, EPV4 SOLAR	EPV4 SUN SHIELD	EPV4 EXTREME COLD
Storage		-20°C ... +45°C		
Operating	in charge mode mains present	-10°C ... +50°C	-10°C ... +55°C	-40°C ... +50°C
	in discharge mode mains absent	-10°C ... +50°C with derating	-10°C ... +50°C with derating	-40°C ... +50°C with derating
Derating		Above -5°C the capacity is maximum; between -5°C and -10°C the capacity drops by 5%; between -10°C and -15°C the capacity drops by 10%; below -15°C the capacity drops by 20%		
Temperatures apply for start-up and operation.				
Solar radiation - EPV4 SUN SHIELD				
Protection		The sunshade provides protection against solar radiation		
Surface temperature		-10°C ... +80°C		
Altitude				
Above 2,000 m, the temperature decreases by 5% every 1,000 m				
Humidity				
0 to 100 % condensing				
MTBF				
100,000 h (with battery) and 200,000 h (without battery) at 25 °C product external environment, rated mains voltage, 75% load				
> Standards				
IEEE Standards				
IEEE 802.1D		Standard Spanning Tree		
IEEE 802.1w		Rapid Spanning Tree (RSTP)		
IEEE 802.1Q		VLAN		
IEEE 802.3i		10BaseT		
IEEE 802.3u		100BaseT(X) and 100BaseFX		
IEEE 802.3ab		1000BaseT(X)		
IEEE 802.3z		1000BaseX		
IEEE 802.3x		Flow Control		
IEEE 802.3af		PoE		
IEEE 802.3at		PoE+		
IEEE 802.3bt		HiPoE (type 1 à 4)		
IEEE 802.3az		Energy Efficient Ethernet		
Electrical and safety standards				
Safety		• EN IEC 62368-1 (2020) + A11 (2020) • EN IEC 62368-3 (2020)		
EMC - Immunity		• EN IEC 61000-6-1 (2019) • EN IEC 61000-6-2 (2019)		
EMC - Emissions		• EN IEC 61000-6-3 (2021) • EN IEC 61000-6-4 (2019)		
		• EN IEC 61000-3-2 (2019) (class A) • EN 55032 (2015) (class A)		
Other standards				
Solar radiation		• EN IEC 60068-2-5 (2018)		
Transport approval		• UN 38.3		
> Accessories				
Pole or wall mounting kit				
Sunshade				
Camera mounting plate				
Battery				



*SLAT reserves the right to modify the characteristics of its products without prior notice.

EPVIDEO EPV5



Power supply on public lighting for a permanent video protection

PoE/PoE+/HiPoE (IEEE 802.3af/at/bt)



OUTDOOR

An on-demand video protection solution for intermittent networks

The EPVIDEO range allows to quickly deploy reliable and durable video protection systems, using existing public lighting infrastructures. It ensures a 24/7 power supply and continuity of service for the equipment in case of power failure



EPV5
278 x 751 x 269 mm



EPV5 SUN SHIELD
299 x 888 x 291 mm

Built-in functions

- ~ Up to two fiber links for a redundant remote connection (RSTP protocols)
- ~ Managed layer 2 switch with up to 6 ports and extensive security features
- ~ Up to 240 W in Power Over Ethernet (PoE / PoE+ / HiPoE / passive PoE)
- ~ Configurable auxiliary voltages: 12 V DC, 24 V DC, 36 V DC, 24 V AC
- ~ Lightning strike protection to up to 40 kA with alarm reporting

The advantages of the EPV5 range

- ~ A solution dedicated to your application, designed on demand to meet your requirements
- ~ Delivered with the associativity certificate that certifies the proper functioning of the whole installation and the guaranteed life span
- ~ Great simplicity of installation thanks to its large door and the assembly on the pole
- ~ Powers all types of PoE and passive PoE antennas and cameras up to 90 W
- ~ Allows data transmission via optical fiber, enabling the creation of daisy chains or loops

*Manufacturer's extended warranty available, contact us for details.

> Modular characteristics of the EPV5 offer			
Switch			
Switch	Managed PoE Switch Layer 2 Up to 6 PoE/PoE+/HiPoE ports including *2 PoE/PoE+ ports *2 PoE/PoE+/HiPoE ports *1 or 2 combo ports (PoE+/SFP)		
Fiber connection	Up to 2 SFP ports		
Network	Connection to the Ethernet, fiber or coaxial networks		
Bandwidth	PoE/PoE+/HiPoE ports	10 / 100 Mbps (compatible with 4K cameras)	
	Combo ports (PoE+/SFP)	100 / 1000 Mbps	
Application layer communication protocols	HTTP, HTTPS, SNMP (v1, v2c, v3)		
Integrated functions	STP/RSTP, VLAN, IGMP, Uplink, QoS, Green Ethernet, automatic and manual Reboot per port		
Power supply			
Power supply	Power supply of the connected equipment Filters interferences from the electrical grid		
	Maximum power	120 W	240 W
	Average power	49 W to 103 W for 8h 23 W to 52 W for 16h of autonomy	49 W to 124 W for 8h 23 W to 60 W for 16h of autonomy
Power supply types	PoE/PoE+/HiPoE (IEEE 802.3af/at/bt - up to 90 W per port) Passive PoE: PoE 55 V / PoE 12V / PoE 24 V 12 V / 24 V / 36 V DC (DC output voltages) 24 V AC		
Battery	Ensures a 24/7 operation over public lighting Sized according to the needs of the installation		
Mains lightning arrester	Protection against lightning up to 40 kA with fault report		
Street lighting shutdown	Ensured operation during the nightly shutdown of the street lighting		
Solar panel	Increased autonomie thanks to the partial charging in hybrid mode		
Additional functions			
Door opening detection	Detection of the door opening and sending the information via SNMP to the supervisor		
Splice cassette	Separation of the fiber strands and creation of the splice		
Sunshade	Protection against solar radiation (surface temperature 80°C)		
Extreme Cold	Operation at very low outdoor temperature (down to -40°C)		
PoE lightning arrester	Protection of the PoE/PoE+/HiPoE outputs and passive PoE		
Camera installation	Removable cable cover plate for the mounting of a dome camera with a maximum diameter of 190 mm and a maximum weight of 4 kg (camera not included). Holes must be drilled as required.		
Available customer space	Space available to accommodate customer equipment (min): W 208 x H 170 x D 106 mm		

SYNAPS IP



Communicating outdoor power supply box with built-in Lithium LFP backup

12 V DC • 24 V DC



OUTDOOR

Designed to meet WiFi, Mesh and video surveillance security requirements



Built-in functions

- ~ Safeguards equipment via a 55 W communicating DC Micro-UPS.
- ~ Filters disturbances of the electrical network.
- ~ 10 kA lightning arrester.
- ~ Reboot function configurable from supervision.
- ~ Secure protocols: SNMP V1 & V3 / HTTPS / BACnet IP.
- ~ Fastenings for customer equipment.

Benefits of the SYNAPS IP range

- ~ Eliminates brown-outs and provides at least 15 min. backup.
- ~ Protects equipment from lightning and electromagnetic disturbances.
- ~ LifePO4 very long-life battery technology.
- ~ Space available for customer equipment (media converter, PoE injector, etc.).
- ~ Designed for outdoor use, with IP65 watertight and IK10 vandal-proof locked box.
- ~ Ultra-compact and lightweight product.

MODEL	WEIGHT (kg)	SIZE W x H x D (mm)	CODE
SYNAPS IP 12V			
SYNAPS 12V 3E N 2E	3.4 kg	200 x 300 x 150	89231713
SYNAPS 12V 3E H 2E	5.1 kg	400 x 300 x 150	89231734
SYNAPS IP 24V			
SYNAPS 24V 3E N 2E	3.4 kg	200 x 300 x 150	89431713
SYNAPS 24V 3E H 2E	5.1 kg	400 x 300 x 150	89431734
OPTIONS	CODE	OPTIONS	CODE
A KIT SYNAPS MP SST	90000227	A KIT POE PASSIF	4690004000
A KIT SYNAPS MP SPACE BOX	90000206	A KIT CONVERTER FO IP 1	90000208
A KIT SYNAPS MURAL	90000222	A KIT CONVERTER FO IP 2	90000209
A KIT SYNAPS ANTI VANDAL	90000203	A KIT SWITCH 5 PORTS EPV	4690009999
A KIT CONVERTER 24 36VDC	90000212	A KIT SPLICE CASSETTE	90000223
A KIT CONVERTER 1224 POE	90000218	PROTEC SMI8-CAT5E	5090020885
A KIT CONVERTER 24 HIPOE	90000217	A KIT 2 HOLE SEALING INSERT	90000224
		PROTEC SMI8-CAT5E	90000225

*Manufacturer's extended warranty available, contact us for details.

SNMP / BACnet IP communication

SYNAPS-IP is a communicating DC Micro-UPS specifically designed for 12 or 24 V DC-powered outdoor video surveillance applications. In the event of power failure, it ensures continuity of service for the equipment it powers with the integrated LiFePO4 backup function.

> Mechanical characteristics							
Boxes	Size W x H x D (mm)	Available customer space (minimum) W x H x D (mm)	Weight (kg)	Materials	Protection rating	CdA	Installation
 Cabinet	200 x 300 x 150*	44 x 200 x 88	3.4	Poly-carbonate	IP65 / IK10	0.066	Wall or post mounted
 SPACE BOX	400 x 300 x 150*	244 x 200 x 88	5.1	Poly-carbonate	IP65 / IK10	0.132	Wall or post mounted
* H with cable glands: + 35 mm / P with lock(s): + 20 mm							
Connections							
- 3 (2+PE) Screw terminals on the lightning arrester (230 V AC power supply). - 1 Output screw terminal (12 or 24 V DC). - Permissible cross-section: 0.75...2.5 mm ²				- Cable feedthrough via 4 watertight cable glands (PSG22). - 2 RJ45 100 Mbps ports.			
Network cables: Ethernet cable Cat 5 or more / shielded or unshielded / straight or twisted							
> Standards-based specifications							
<ul style="list-style-type: none"> • EN IEC 62368-1 (2020) + A11 (2020) • EN IEC 61000-6-1 (2019) • EN IEC 61000-6-2 (2019) • EN IEC 61000-3-2 (2019) class A • EN IEC 61000-6-3 (2021) • EN IEC 61000-6-4 (2019) • EN 55032 Class B • UN 38.3 Ethernet IEEE 802.3 10BASE-T, IEEE 802.3u 100BASE-T, Flow Control IEEE802.3x, IEEE802.3az (Energy Efficient Ethernet EEE)					   		
> Environmental specifications							
Temperature							
Storage			-20 à +45°C				
Operating			-10 to +50°C in normal and backup modes				
			-5 to +50°C in battery charge mode				
Humidity							
From 0 to 100% (condensing)							
Altitude							
Above 2,000 m, the temperature decreases by 5% every 1,000 m.							
MTBF							
100,000 h (with battery) and 200,000 h (without battery) at 25 °C product external environment, rated mains voltage, 75% load							
> Electrical characteristics							
Network input							
AC network voltage			99 to 264 V AC				
DC network voltage			140 to 375 V DC				
Frequency			45 to 65 Hz				
Class			Class 1				
Current			Inrush current limited by NTC				
Neutral systems			TT, TN, IT				
Protection against			primary short circuit and differential mode shock waves.				
Primary current @ 99 V AC			1.5 A				
Primary current @ 264 V AC			0.38 A				
Lightning arrester			Type 2 / 10 kA				

> Operating output			
Rated voltage (U_n)	12 V DC		24 V DC
Available output power	55 W		
Constant voltage adjustable via HTTPS interface	-8% to +13%		
Maximum power on terminal block [55 W]	4.6 A		2.3 A
Permissible current peaks	9 A / 12 ms 23 A / 4 ms		4.6 A / 8 ms 11 A / 1.6 ms
Output (Smart Backup)	η @ 20% loading	η @ 75% loading	η @ 100% loading
	85%	91%	90%

> Functional characteristics

Operates in power-saving mode when the backup is charged.
Filters disturbances of the electrical network.
Without fan.
Indicates the % of remaining autonomy.
IP 65 cabinet
Lithium LFP Smart Backup
Latest generation Lithium LiFePO4 Technology (no risk of thermal runaway).
Lead-free, cadmium-free, 100% recyclable.
Storage: 9 months without recharging.
10 year service life.
Advanced management settings, cell balancing, overload and overvoltage protection.
A built-in push button disconnects the backup via a static switch. The battery is automatically reconnected when mains voltage is restored.

> Backup duration according to output power - 55 W (Type 3)

	<p>CABINETS 12 V / 24 V</p>  <p>Backup 3E</p>
Operating power	Autonomy expressed in hours and minutes
5 W	5h49
7 W	4h30
10 W	3h21
15 W	2h20
20 W	1h46
25 W	1h26
30 W	1h12
35 W	1h02
40 W	0h54
45 W	0h48
50 W	0h43
55 W	0h39

Protections

Against atmospheric or industrial overvoltages on primary (10 kA lightning arrester).
Against user output overvoltages (deregulation or connection error) and by cutting with cyclical restarting if output voltage $> U_n + 10\%$.
Against overloads by limiting the power supply to $P_n + 10\%$.
Against output short-circuits by disconnecting the power supply with cyclical restart.

MMI				
LED for status display and control (on board).				
Steady green	Flashing green	Slow flashing orange	Fast flashing orange	Red
Normal mode	ECO mode Stealth mode	Backup mode	Installation fault - Overcurrent, short circuit - Low voltage output (product overload). - Power supply temperature too high - No mains (outside specified power supply range). End of backup imminent	UPS to be changed - If no output voltage - If power supply out of order (charger fault). Backup fault - Backup undervoltage. - Backup overvoltage.
LEDs to give the status of the Ethernet port activity (Link / Act)				
Steady green		Flashing green		
Connection established		- Connection established - Activity on the Ethernet link		
Communication				
2 x 100 Mbps ports make it possible to connect SYNAPS IP to an Ethernet network in order to remotely view information (product serial number, system status), to communicate analog values (voltage and load current, % of backup remaining, power status, internal temperature of the UPS DC) and to configure its settings via the on-board HTTPS web site.				
Auto MDI/MDI-X	yes			
MAC address table	8,000 entries			
Transmission method	Store & Forward			
Internal switch capacity	650 Mbps			
Frame size and latency (max)	1,518 octets / 126 µs			
Improved version of the micro program	Upgrade via HTTPS web browser			
Protocols supported: IPv4, HTTPS, TCP, UDP, ICMP, ARP, DHCP, SNMP V1 & V3, BACnet IP.				
> Accessories and options				
Model	Description			
A KIT SYNAPS MP SST	Pole mounting kit			
A KIT SYNAPS MP SPACE BOX	Pole mounting kit for SPACE BOX			
A KIT SYNAPS MURAL	Wall mounting kit			
A KIT SYNAPS ANTI VANDAL	Protection against cable cutting			
A KIT CONVERTER 24 36 VDC	Voltage converter: input 24 VDC, output 36 VDC			
A KIT CONVERTER 1224 POE	PoE/PoE+ injector			
A KIT CONVERTER 24 HIPOE	HiPoE injector			
A KIT POE PASSIF	Passive PoE injector			
A KIT CONVERTER FO IP 1	Media converter: fiber optic to RJ45			
A KIT CONVERTER FO IP 2	Media converter: fiber optic to RJ45			
A KIT SWITCH 5 PORTS EPV	5 port Ethernet switch			
A KIT SPLICE CASSETTE	Fiber splice cassette			
PROTEC SMJ8-CAT5E	Lightning arrester for Ethernet ports			

*SLAT reserves the right to modify the characteristics of its products without prior notice.

SYNAPS PoE 2 / PoE 4



Outdoor network interface with 2 to 4 PoE ports switch and built-in Lithium LFP backup power supply

PoE/PoE+ (IEEE 802.3af/at)



OUTDOOR

Designed to meet outdoor video, along with WiFi and Mesh network security requirements.



Built-in functions

- ~ Safeguards up to 4 PoE/PoE+ devices, with a total PoE budget of 55 W.
- ~ Device Activity Monitoring for automatic per-port reboot.
- ~ Filters disturbances of the electrical network.
- ~ 10 kA lightning arrester.
- ~ Reboot function configurable from supervision.
- ~ Protected and backed up Ethernet switch with up to 4 PoE ports and one Ethernet Uplink.
- ~ Secure protocols: SNMP V1 & V3 / HTTPS / BACnet IP.
- ~ Fastenings for customer equipment.

Benefits of the SYNAPS PoE 2 / PoE 4 range





- ~ Eliminates brown-outs and provides at least 15 min. backup.
- ~ Protects equipment from lightning and electromagnetic disturbances.
- ~ LifePO4 very long-life battery technology.
- ~ Space available for customer equipment (media converter)
- ~ Designed for outdoor use, with IP65 watertight and IK10 vandal-proof locked cabinet.
- ~ Ultra-compact and light weight product.

MODEL	WEIGHT (kg)	SIZE W x H x D	CODE
SYNAPS PoE			
SYNAPS-POE 3B N 2P1E	3.1 kg	200 x 300 x 150	89939716
SYNAPS-POE 3E N 2P1E	3.6 kg	200 x 300 x 150	89939716
SYNAPS-POE 3E P4	3.5 kg	200 x 300 x 150	89931716
OPTIONS			
OPTIONS	CODE	OPTIONS	CODE
A KIT SYNAPS MP SST	90000227	A KIT CONVERTER FO POE 1	90000210
A KIT SYNAPS MURAL	90000222	A KIT CONVERTER FO POE 2	90000211
A KIT SYNAPS ANTI VANDAL	90000203	A KIT EXTENDER POE COAX	90000215
A KIT CONVERTER 55 12VDC	90000213	A KIT SWITCH 5 PORTS EPV	4690009999
A KIT CONVERTER 55 24VDC	90000216	A KIT SPLICE CASSETTE	90000223
A KIT CONVERTER POE POE1224	90000214	PROTEC SMJ8-POE-A	5090020888
A KIT 2 HOLE SEALING INSERT	90000224	A KIT 3 HOLE SEALING INSERT	90000225

*Manufacturer's extended warranty available, contact us for details.

SNMP / BACnet IP / HTTPS communication

SYNAPS-PoE is an outdoor network interface box dedicated to video applications and PoE powered transmissions. It performs energy conversion and data switching. In the event of a brown-out, it ensures continuity of service for the equipment that it protects with the built-in Lithium LFP battery.

> Mechanical characteristics							
Boxes	Size W x H x D (mm)	Available customer space (minimum) W x H x D (mm)	Weight (kg)	Materials	Protection rating	CdA	Installation
 Cabinet	200 x 300 x 150*	60 x 200 x 88	3.5	Poly-carbonate	IP65 / IK10	0.066	Wall or post mounted
* H with cable glands: + 35 mm / P with lock(s): + 20 mm							
Connections							
- 3 (2+PE) Screw terminals on the lightning arrester (230 V AC power supply). - 1 Output screw terminal (55 V DC). - Permissible cross-section: 0.75...2.5 mm²				- Cable feedthrough via 4 or 8 watertight cable glands (PG22). - 1 RJ45 1 Gbps port. - 2 or 4 PoE / PoE+ 100 Mbps Ports.			
Network cables: Ethernet cable Cat 5 or more / shielded or unshielded / straight or twisted							
> Standards-based specifications							
EN IEC 62368-1 (2020) + A11 (2020) • EN IEC 61000-6-1 (2019) • EN IEC 61000-6-2 (2019) • EN IEC 61000-3-2 (2019) class A • EN IEC 61000-6-3 (2021) • EN IEC 61000-6-4 (2019) • EN 55032 Class B • UN 38.3 Ethernet IEEE 802.3 10BASE-T, IEEE 802.3u 100BASE-T, Flow Control IEEE802.3x, IEEE802.3az (Energy Efficient Ethernet EEE)				   			
> Environmental specifications							
Temperature							
Storage			-20 à +45°C				
Operating			-10 to +50°C in normal and backup modes				
			-5 to +50°C in battery charge mode				
Humidity							
From 0 to 100% (condensing)							
Altitude							
Above 2,000 m, the temperature decreases by 5% every 1,000 m.							
MTBF							
100,000 h (with battery) and 200,000 h (without battery) at 25 °C product external environment, rated mains voltage, 75% load							
> Electrical characteristics							
Network input							
AC network voltage			99 to 264 V AC				
DC network voltage			140 to 375 V DC				
Frequency			45 to 65 Hz				
Class			Class 1				
Current			Inrush current limited by NTC				
Neutral systems			TT, TN, IT				
Protection against			primary short circuit and differential mode shock waves.				
Primary current @ 99 V AC			1.5 A				
Primary current @ 264 V AC			0.38 A				
Lightning arrester			Type 2 / 10 kA				

> Operating output			
PoE technology	IEEE 802.3af, IEEE 802.3at, PSE type B		
Rated voltage (U_n)	55 V DC		
Budget PoE via RJ45 port	30 W		
Total PoE budget	55 W		
Output (Smart Backup)	η @ 20% loading	η @ 75% loading	η @ 100% loading
	85%	91%	90%

> Functional characteristics			
Operates in power-saving mode when the backup is charged.			
Filters disturbances of the electrical network.			
Without fan.			
Indicates the % of remaining autonomy.			
Per-port start/stop function			
Configurable manual reboot function.			
Per-port configurable DAM function (automatic shutdown and restart).			
IP65 cabinet			

Lithium LFP Smart Backup			
Latest generation Lithium LiFePO4 Technology (no risk of thermal runaway).			
Lead-free, cadmium-free, 100% recyclable.			
Storage: 9 months without recharging.			
10 year service life.			
Advanced management settings, cell balancing, overload and overvoltage protection.			
A built-in push button disconnects the backup via a static switch. The battery is automatically reconnected when mains voltage is restored.			

> Backup duration according to output power - 55 W (Type 3)

		CABINETS PoE / PoE+ 	
		Backup 3B	Backup 3E
Operating power	Autonomy expressed in hours and minutes		
5 W	Minimum 3 seconds		5h01
7 W			4h
10 W			3h04
15 W			2h12
20 W			1h42
25 W			1h23
30 W			1h10
35 W			1h
40 W			0h53
45 W			0h47
50 W			0h43
55 W			0h39

Protections	
Against atmospheric or industrial overvoltages on primary (10 kA lightning arrester).	
Against user output overvoltages (deregulation or connection error) and by cutting with cyclical restarting if output voltage > $U_n + 10\%$.	
Against overloads by limiting the power supply to $P_n + 10\%$.	
Against output short-circuits by disconnecting the power supply with cyclical restart.	

MMI				
LED for status display and control (on board).				
Steady green	Flashing green	Slow flashing orange	Fast flashing orange	Red
Normal mode	ECO mode Stealth mode	Backup mode	Installation fault - Overcurrent, short circuit - Low voltage output (product overload). - Power supply temperature too high - No mains (outside specified power supply range). End of backup imminent	UPS to be changed - If no output voltage - If power supply out of order (charger fault). Backup fault - Backup undervoltage. - Backup overvoltage.
LEDs to give the status of the Ethernet port activity (Link / Act)				
Steady green		Flashing green		
Connection established		- Connection established - Activity on the Ethernet link		
LED to give the status of the PoE / PoE + power supply				
Steady orange		Off		
PoE active		PoE inactive		
Communication				
1 x 1 Gbps port makes it possible to connect the end switch to the Ethernet network (or for local diagnosis) in order to consult information remotely (product serial number, system status), to communicate analog values (voltage and load current, % of backup remaining, power status, internal temperature of the UPS DC) and to configure its settings via the on-board HTTPS website.				
2 or 4 x 100 Mbps PoE / PoE+ ports make it possible to connect the SYNAPS-PoE to protected equipment and to transmit their data or video feeds to supervision systems.				
Auto MDI/MDI-X	yes			
MAC address table	8,000 entries			
Transmission method	Store & Forward			
Internal switch capacity	650 Mbps			
Frame size and latency (max)	1,518 octets / 126 µs			
Improved version of the micro program	Upgrade via HTTPS web browser			
Protocols supported: IPv4, HTTPS, TCP, UDP, ICMP, ARP, DHCP, SNMP V1 & V3, BACnet IP.				
> Accessories and options				
Model	Description			
A KIT SYNAPS MP SST	Post mounting kit			
A KIT SYNAPS MURAL	Wall mounting kit			
A KIT SYNAPS ANTI VANDAL	Anti-vandalism kit: protection against cable cutting			
A KIT CONVERTER 55 12VDC	Voltage converter: input 55 V DC, output 12 V DC			
A KIT CONVERTER 55 24VDC	Voltage converter: input 55 V DC, output 24 V DC			
A KIT CONVERTER POE POE1224	Injector/converter from IEEE 802.3af/at PoE to 12 or 24 V DC PoE			
A KIT CONVERTER FO POE 1	Ethernet/fibre optic media converter (1 fiber ports)			
A KIT CONVERTER FO POE 2	Ethernet/fibre optic media converter (2 fiber port)			
A KIT EXTENDER POE COAX	Coaxial extension kit for Ethernet /PoE network			
A KIT SWITCH 5 PORTS EPV	5-port unmanaged Fast Ethernet switch			
A KIT SPLICE CASSETTE	Fiber splice cassette			
PROTEC SMJ8-POE-A	Surge protector for PoE/PoE+/HiPoE ports			

*SLAT reserves the right to modify the characteristics of its products without prior notice.

SYNAPS PoE 5 / PoE 6



Network interface with built-in managed switch (HiPoE, fiber) and Lithium LFP backup

PoE/PoE+/HiPoE (IEEE 802.3af/at/bt)



OUTDOOR

Uninterrupted videoprotection and connected city devices

The SYNAPS PoE 5 and PoE 6 cabinets enable a quick deployment of the connected objects in the city. They contain all the necessary equipment required to build a connection and provide the essential software functions to securely connect to the network.



Synaps PoE 5

Synaps PoE 6

300 x 400 x 150 mm



Built-in functions

- ~ PoE power supply for equipments up to 90 W
- ~ Managed 5 or 6 port switch Layer 2
- ~ Up to 2 fiber links for a redundant remote connection with RSTP protocol
- ~ Secure webserver and SNMP link
- ~ Supplies up to 150 W on Power Over Ethernet
- ~ Configurable auxiliary voltage: 12 V DC or 24 V DC
- ~ Automatic reboot configurable on each port
- ~ 10 kA lightning arrester for lightning strikes

Benefits of the SYNAPS PoE 5 / PoE 6 range

- ~ Manages the data flows thanks to its dedicated functions (VLAN, Multicast, QoS, SysLog, ...)
- ~ Protects against lightning strikes and power outages
- ~ Ensures an uninterrupted operation 365 days a year with automatic 1st-level maintenance
- ~ Transmits data up to 20 km by optical fiber
- ~ Provides space for customer equipment
- ~ Designed for outdoor use with waterproof, vandalproof box
- ~ Lithium battery SLAT with 10-year service life

*Extension of the manufacturer's warranty possible, contact us for details.

MODEL	WEIGHT (kg)	SIZE W x H x D (mm)	CODE
SYNAPS PoE 5 / PoE 6			
SYNAPS-POE 5F V 4P1C	6.3 kg	300 x 400 x 150	89252764
SYNAPS-POE 5F V 4P2C	6.3 kg	300 x 400 x 150	89452764
OPTIONS	CODE	OPTIONS	CODE
A KIT SYNAPS MP HIGH BOX SST	90000228	A KIT SPLICE CASSETTE	90000223
A KIT SYNAPS MURAL	90000222	A KIT EXTENDER POE COAX	90000215
A KIT SYN TAMPER SWITCH	90000204	PROTEC SMJ8-POE-A	5090020888
A KIT POE PASSIF	4690004000	A KIT 2 HOLE SEALING INSERT	90000224
		A KIT 3 HOLE SEALING INSERT	90000225

> Mechanical characteristics							
Boxes	Size W x H x D (mm)	Available customer space (min) W x H x D (mm)	Weight (kg)	Materials	Protection rating	CdA	Installation
High Box 	300 x 400 x 150*	107 x 160 x 115 130 x 160 x 115	6.3	Poly-carbonate	IP65 / IK10	0.132	Wall or post mounted
* H with cable glands: + 35 mm / P with locks: + 20 mm							
Connections							
Mains	3 (2+PE) Screw terminals on the lightning arrester (230 V AC power supply)						
PoE/PoE+/HiPoE ports	4 RJ45 ports (100 Mbps) : Ethernet cable Category 5 or more, shielded, straight or twisted cables						
Combo ports (SYNAPS PoE 5)	1 Combo port: or	RJ45 port: Ethernet cable Category 5e or more, shielded, straight or twisted cables (1 Gbps)					
		SFP port: SFP module 1 Gbps transceiver					
Combo ports (SYNAPS PoE 6)	2 Combo ports: or	RJ45 port: Ethernet cable Category 5e or more, shielded, straight or twisted cables (1 Gbps)					
		SFP port: SFP module 1 Gbps transceiver					
DC Output	1 DC output: Screw terminal with plug-in connector with polarizing slot						
Digital Input	Screw terminal with plug-in connector with polarizing slot (1 input)						
Dry Contact	Screw terminal with plug-in connector with polarizing slot (open collector: 50 mA @ 60 V DC)						
Cable cross-section	Max. 2,5 mm ² (Mains, digital input and dry contact)						
Cable feedthrough	Via 8 watertight cable glands						
> Electrical input characteristics							
AC network voltage	175 V to 265 V AC single-phase						
Frequency	45 Hz à 65 Hz						
Class	1						
Inrush current	25 A, limited by NTC						
Neutral system	TT, TN						
Protection against	primary short-circuit and differential mode shock waves						
Primary current @ 175 V AC	1.3 A						
Primary current @ 265 V AC	0.7 A						
Upstream circuit breaker to be provided	D curve						
Lightning arrester	Type 2 / 10 kA (Synaps PoE 5)						
	Type 2 / 40 kA (Synaps PoE 6)						
> Electrical output characteristics							
Maximum power (PoE + DC Output)	150 W						
PoE							
PoE ports	5 or 6 PoE / PoE+ / passif PoE ports including 2 HiPoE ports						
PoE/PoE+	IEEE 802.3af/at - 15 W / 30 W per port; Mode B						
HiPoE	IEEE 802.3bt - 15 W / 30 W / 60 W / 90 W per port; power supply over 4 PoE pairs (4PPoE)						
Passif PoE	55 V PoE: all PoE ports, 30 W* operating. 12 V PoE / 24 V PoE: Combo port(s) , 1 A* operating. * Max. 400 mA at startup.						
PoE budget	Per port PoE function configuration						
Operating output							
DC output	12 V DC or 24 V DC						
Current limitation	12 V DC : In = 7.2 A, U > 50% Un 24 V DC : In = 4.4 A, U > 50% Un						
Output voltage regulation	≤ 1%						
LF ripple	<5 mV effective at In						
Max. available power at DC output	12 V DC : 60 W 24 V DC : 96 W						

> Switch properties		
Switch	Layer 2	
Queues per port	4	
Max. number of VLANs	4094	
VLAN ID range	VID 1 to 4094	
Max. number of IGMP groups (multicast)	1024	
Number of MAC addresses	Up to 8000 MAC addresses	
Max. length Jumbo Frame	10 kB	
Packet buffer memory	1 Mbit	
Communication		
Communication speed	PoE ports	10 / 100 Mbps
	Combo ports	100 / 1000 Mbps
Application layer protocols	HTTP, HTTPS, SNMP (v1, v2c, v3),	
Network layer protocols	IPv4, ICMP	
Management (Web, SNMP)		
Web GUI interface / Web server	Built-in switch configuration utility for browser-based device configuration (HTTPS). Supports configuration, system dashboard, maintenance and monitoring; Visualisation of the operating states	
Firmware update	Upgrade via web browser (HTTPS)	
SNMP	SNMP v1, v2c, v3	
Alarm management	SNMP trap sending	
> Switching characteristics		
The configuration of the switch functions is done via the embedded website.		
Switch Layer 2		
VLAN	Supports up to 4K VLANs simultaneously (out of 4094 VLAN IDs); Port-based VLAN; 802.1Q tag-based VLAN	
IGMP v1/v2 Snooping	IGMP limits bandwidth-intensive multicast traffic to only the requesters; it supports 1024 multicast groups (source-specific multicasting is also supported)	
Uplink	Uplink mode limits the sending of multicast traffic on the combo port	
Log/SysLog	Records events locally and sends them to one or two specific servers	
NTP	Allows the switch clock to be synchronised with the network clock	
Spanning Tree Protocol (STP)	Standard Spanning Tree (STP) IEEE 802.1D	
	Rapid Spanning Tree (RSTP) IEEE 802.1w	
Security		
Website	HTTPS (HTTP operation possible) Management administrator account vs. user account	
HTTPS	Authentication and encryption with a root certificate (CA) Allows secure access to the switch management webserver	
SNMP	SNMP V3 with data encryption	
Protocol for securing exchanges	TLS (Transport Layer Security, versions 1.0 to 1.3) SSL not supported (banned by RFC 7568)	
Quality of Service		
Hardware Priority Queue	Supports 4 hardware queues	
Scheduling	Strict priority and weighted round-robin (WRR)	
	Queue assignment based on DSCP and class of service (802.1p/ CoS)	
Classification	Port based; 802.1p VLAN priority based; IPv4 precedence/ type of service (ToS) / DSCP based	
Green Ethernet		
Link detection	Compliant IEEE802.3az Energy Efficient Ethernet Task Force. Automatically turns off power on Gigabit Ethernet RJ45 port when detecting link down or Idle of client. Active mode is resumed without loss of any packets when the switch detects the link up.	
Cable length detection	Adjusts the signal strength based on the cable length. Reduces the power consumption for shorter cables.	
Eco Mode	Shifts automatically to power-saving mode.	

> Signaling	
5 or 6 LEDs indicate the PoE activity on the corresponding port	
5 or 6 LEDs indicate the data transmission activity on the corresponding port	
1 LED indicates the operation of the lightning arrester	
> Environmental specifications	
Temperature	
Storage	-20°C ... +45°C
Operating	-10°C ... +50°C at 120 W nominal power in backup and normal mode
	-10°C ... +45°C at 150 W nominal power in backup and normal mode
Humidity	
From 0 to 100% condensing	
Altitude	
Above 2,000 m, the temperature decreases by 5% every 1,000 m	
MTBF	
100,000 h (with battery) and 200,000 h (without battery) at 25 °C product external environment, rated mains voltage, 75% load	
> Caractéristiques fonctionnelles	
Operation	Operates in power-saving mode when the backup is charged.
Network filtering	Filters out power grid disturbances.
Cooling	Without fan.
Autonometer	Informs of the percentage of the remaining autonomy.
Restart function	Allows manual remote control of the on/off function per PoE port / DC output.
DAM function	Allows the monitoring of the connected products with an automatic reboot in the event of a fault. Configurable per port.
Protections	
Against atmospheric or industrial overvoltage on primary (10 kA lightning arrester).	
Against too high currents on the auxiliary output (50 mA).	
Against overcurrent and short circuits on the output by disconnecting the PoE port.	
> Lithium LFP Smart Backup	
Latest generation Lithium LiFePO4 Technology (no risk of thermal runaway).	
Lead-free, cadmium-free, 100% recyclable.	
Storage: 9 months without recharging.	
10 year service life.	
Advanced management settings, cell balancing, overcurrent and overvoltage protection.	
> Backup duration according to output power	
	Backup F
Operating power	Autonomy expressed in hours and minutes
10 W	4h24
20 W	2h28
30 W	1h43
40 W	1h19
50 W	1h04
60 W	0h54
70 W	0h46
80 W	0h41
90 W	0h36
100 W	0h33
110 W	0h30
120 W	0h27
130 W	0h25
140 W	0h23
150 W	0h22

> Standards	
IEEE Standards	
IEEE 802.1D	Standard Spanning Tree
IEEE 802.1w	Rapid Spanning Tree (RSTP)
IEEE 802.1Q	VLAN
IEEE 802.3i	10BaseT
IEEE 802.3u	100BaseT(X) and 100BaseFX
IEEE 802.3ab	1000BaseT(X)
IEEE 802.3z	1000BaseX
IEEE 802.3x	Flow Control
IEEE 802.3af	PoE
IEEE 802.3at	PoE+
IEEE 802.3bt	HiPoE (type 1 à 4)
IEEE 802.3az	Energy Efficient Ethernet
Electrical and safety standards	
Safety	<ul style="list-style-type: none"> • EN IEC 62368-1 (2020) + A11 (2020) • EN IEC 62368-3 (2020)
EMC - Immunity	<ul style="list-style-type: none"> • EN IEC 61000-6-1 (2019) • EN IEC 61000-6-2 (2019)
EMC - Emissions	<ul style="list-style-type: none"> • EN IEC 61000-6-3 (2021) • EN IEC 61000-6-4 (2019)
	<ul style="list-style-type: none"> • EN IEC 61000-3-2 (2019)(class A)
	<ul style="list-style-type: none"> • EN 55032 (2015) (class A)
Other standards	
Transport approval	UN 38.3



*SLAT reserves the right to modify the characteristics of its products without prior notice.

SYNAPS PoE 8



Network interface with built-in managed switch (HiPoE, fiber) and Lithium LFP backup

PoE/PoE+/HiPoE (IEEE 802.3af/at/bt)



OUTDOOR

Designed to meet the requirements of video applications, connected city objects along with WiFi and Mesh security networks



SYNAPS PoE 8
300 x 400 x 150 mm

Built-in functions

- ~ Provides 180 W in Power Over Ethernet
- ~ Powers and secures up to 8 PoE/PoE+/HiPoE devices
- ~ Two independent or redundant fiber links
- ~ Managed layer 2 switch
- ~ Protected and backed-up switch with extended security features
- ~ Device Activity Monitoring for an automatic reboot of each port.
- ~ Control of the connected objects by secured webserver
- ~ 10 kA lightning arrester for lightning strikes
- ~ Long-life LiFePO4 battery technology

Key product features

- ~ Powers all types of PoE cameras up to 90 W
- ~ Allows data transmission up to 20 km via optical fiber
- ~ Efficiently manages the video flows thanks to its multiple dedicated functions
- ~ Eliminates brown-outs and provides at least 14 minutes of backup
- ~ Protects the equipment from lightning and electromagnetic disturbances
- ~ Provides space for customer equipment (4G modem, recorder...)
- ~ Designed for outdoor use with a watertight, vandalproof box and a stainless steel plate
- ~ Easy to install thanks to its large door with key lock

*Extension of the manufacturer's warranty possible, contact us for details

MODEL	WEIGHT (kg)	SIZE W x H x D (mm)	CODE
SYNAPS PoE 8			
SYNAPS-POE 5F V 8P2F	6.6 kg	300 x 400 x 150	89952765
OPTIONS	CODE	OPTIONS	CODE
A KIT SYNAPS MP HIGH BOX SST	90000228	A KIT SPLICE CASSETTE	90000223
A KIT SYNAPS MURAL	90000222	A KIT EXTENDER POE COAX	90000215
A KIT SYN TAMPER SWITCH	90000204	PROTEC SMJ8-POE-A	5090020888
A KIT CONVERTER POE POE1224	90000214		



SNMP / BACnet IP communication

> Mechanical characteristics							
Boxes	Size W x H x D (mm)	Available customer space (minimum) W x H x D (mm)	Weight (kg)	Materials	Protection rating	CdA	Installation
High Box 	300 x 400 x 150*	110 x 160 x 115 130 x 160 x 115	6.6	Poly-carbonate	IP65 / IK10	0.132	Wall or post mounted
* H with cable glands: + 35 mm / D with locks: + 20 mm							
Connections							
Mains	3 (2+PE) Screw terminals on the lighting arrester (230 V AC power supply)						
PoE ports	8 RJ45 ports	Ethernet cable Category 5e or more (PoE/PoE+)/ Category 6a or more (HiPoE) shielded, straight or twisted cables					
SFP ports	2 SFP ports	SFP module 1000 Mbps transceiver					
Digital Input/ Dry Contact	Screw terminal with plug-in connector with polarizing slot						
Cable feedthrough via 8 watertight cable glands (PSG22)							
> PoE							
PoE/PoE+/HiPoE Ports	4 ports, support PoE Power Pin Type: End-span (Mode A) IEEE 802.3af/at/bt - 15 W / 30 W / 60 W / 90 W per port						
PoE/PoE+ Ports	4 ports, support PoE Power Pin Type: End-span (Mode A) IEEE 802.3af/at - 15 W / 30 W per port						
Power	Per port PoE function configuration						
PoE Budget	180 W						
> Communication							
Communication speed	PoE ports	10 / 100 / 1000 Mbps					
	SFP ports	100 / 1000 Mbps					
Application layer protocols	HTTPS, BACnet IP, SNMP (v1, v2c, v3), DHCP						
Network layer protocols	IPv4, ICMP						
> Switch properties							
Priority Queues	8						
Max. Number of VLANs	4094						
VLAN ID Range	VID 1 to 4094						
IGMP Groups	1024						
MAC Table Size	Up to 8K MAC addresses						
Jumbo Frame Size	9.6 KB						
Performance							
Capacity of the forwarding rate in Millions of Packets per Second (Mpps) (64-byte packets)	14.88 Mpps						
Switching Capacity in Gigabits per Second (Gbps)	20 Gbps						

> Switching characteristics	
Layer 2 Switching	
Spanning Tree Protocol (STP)	Standard Spanning Tree (STP) IEEE 802.1D Rapid Spanning Tree (RSTP) IEEE 802.1w
Aggregation	Link Aggregation Control Protocol (LACP) IEEE 802.3ad; Up to 5 groups, up to 8 ports per group
VLAN	Supports up to 4K VLANs simultaneously (out of 4094 VLAN IDs); Port-based VLAN; 802.1Q tag-based VLAN
IGMP v1/v2 Snooping	IGMP limits bandwidth-intensive multicast traffic to only the requesters; it supports 1024 multicast groups (source-specific multicasting is also supported)
Security	
Secure Sockets Layer (SSL), HTTPS	SSL encrypts the http traffic, allowing advance secure access to the browser-based management GUI in the switch
Port Sicherheit	Locks MAC Addresses to ports, and limits the number of learned MAC addresses
IP Source Guard	Prevents datagram with spoofed addresses from being in the network
Storm control	Prevents traffic on a LAN from being disrupted by a broadcast, multicast or unicast storm on a port
ACLs	Supports for up to 256 entries; Drop or rate limitation based on source and destination MAC, VLAN ID or IP address, protocol, port, differentiated services code point (DSCP) / IP precedence, TCP/ UDP source and destination ports, 802.1p priority, Ethernet type, Internet Control Message Protocol (ICMP) packets, IGMP packets, TCP flag
Quality of Service	
Hardware Priority Queue	Supports 8 hardware queues
Scheduling	Strict priority and weighted round-robin (WRR) Queue assignment based on DSCP and class of service (802.1p/ CoS)
Classification	Port based; 802.1p VLAN priority based; IPv4 precedence/ type of service (ToS) / DSCP based
Rate Limiting	Ingress policer; egress shaping and rate control; per VLAN, per port and flow based
Management (Web/SSL, SNMP, BACnet)	
Web GUI interface	Built-in switch configuration utility for browser-based device configuration (HTTPS). Supports configuration, system dashboard, maintenance and monitoring.
Firmware upgrade	Web browser upgrade (HTTPS)
Port mirroring	Traffic on a port can be mirrored to another port for analysis with a network analyzer or RMON probe. Up to N-1 (N is Switch's Ports) ports can be mirrored to a single destination port. A single session is supported.
Other management	Single IP management; HTTPS; RADIUS; DHCP Client; SNMP; cable diagnostics
Green Ethernet	
Link detection	Compliant IEEE802.3az Energy Efficient Ethernet Task Force. Automatically turns off power on Gigabit Ethernet RJ45 port when detecting link down or Idle of client. Active mode is resumed without loss of any packets when the switch detects the link up.
Cable length detection	Adjusts the signal strength based on the cable length. Reduces the power consumption for shorter cables.
Eco Mode	Shifts automatically to power-saving mode.
Discovery	
Link Layer Discovery Protocol (LLDP)	Used by network devices for advertising their identities, capabilities and neighbors on a IEEE 802 local area network, principally wired Ethernet.
The configuration of the switch functions is done via the embedded website.	

> Signaling	
1 LED for the "PoE Load" level on the front panel	
1 LED for the product "Status" on the front panel	
8 LEDs indicate the PoE activity on the corresponding port (green)	
8 LEDs indicate the data transmission activity on the corresponding port (yellow)	
> Environmental specifications	
Temperature	
Storage	-20°C à +45°C
Operating	at 100% load: -10°C ... +45°C
	at 50% load: -10°C ... +50°C
Humidity	
0 to 100 % condensing	
Altitude	
Above 2,000 m, the temperature decreases by 5% every 1,000 m.	
MTBF	
100,000 h (with battery) and 200,000 h (without battery) at 25 °C product external environment, rated mains voltage, 75% load	
> Electrical characteristics	
Network Input	
AC network voltage	198 to 264 V AC
Frequency	45 to 65 Hz
Class	1
Inrush current	Limited by NTC
Neutral system	TT, TN, IT
Protection against	primary short-circuit and differential mode shock waves
Primary current @ 198 V	1.85 A
Primary current @ 264 V	1.70 A
Lightning arrester	Type 2 / 10 kA
Functional characteristics	
Operates in power-saving mode when the backup is charged.	
On/Off function per PoE port.	
Filters disturbances of the electrical network.	
Fan-cooling.	
Configurable reboot function (stop and restart automatically) on each PoE-port.	
Indicates the % of the remaining autonomy.	
Protections	
Against atmospheric or industrial overvoltage on primary (10 kA lightning arrester).	
Against overload by power limitation to $P_n + 10\%$.	
Against overcurrent and short-circuits on the output by disconnecting the PoE port at $I > I_n + 10\%$.	
Smart backup	
SYNAPS-PoE 8 is available with the backup pack	5F
Latest generation Lithium LiFePO4 Technology (no risk of thermal runaway).	
Lead-free, cadmium-free, 100% recyclable.	
Storage: 9 months without recharging.	
10 year service life.	
Advanced management settings, cell balancing, overload and overvoltage protection.	
A built-in push button disconnects the backup via a static switch. The battery is automatically reconnected when mains voltage is restored	

Backup duration according to output power	
Operating power	Backup F Autonomy expressed in hours and minutes
10 W	2h07
20 W	1h29
30 W	1h09
40 W	0h55
50 W	0h46
60 W	0h40
70 W	0h35
80 W	0h31
90 W	0h28
100 W	0h25
110 W	0h23
120 W	0h21
130 W	0h20
140 W	0h18
150 W	0h17
160 W	0h16
170 W	0h15
180 W	0h14

> Standards	
IEEE Standards	
IEEE 802.1D	Standard Spanning Tree
IEEE 802.1w	Rapid Spanning Tree (RSTP)
IEEE 802.1Q	VLAN
IEEE 802.1X	Radius
IEEE 802.3ad	Link Aggregation Control Protocol (LACP)
IEEE 802.3i	10BaseT
IEEE 802.3u	100BaseT(X) and 100BaseFX
IEEE 802.3ab	1000BaseT(X)
IEEE 802.3z	1000BaseX
IEEE 802.3x	Flow Control
IEEE 802.3af	PoE
IEEE 802.3at	PoE+
IEEE 802.3bt	HiPoE (type 3 & 4)
IEEE 802.3az	Energy Efficient Ethernet
Electrical standards	
Safety	• EN IEC 62368-1 (2020) + A11 (2020)
EMC - Immunity	• EN IEC 61000-6-1 (2019) • EN IEC 61000-6-2 (2019)
EMC - Emissions	• EN IEC 61000-6-3 (2021) • EN IEC 61000-6-4 (2019)
	• EN IEC 61000-3-2 (2019) (class A)
	• EN 55032 (2015) (class B)
   	
Security standards	
Transportation security	UN 38.3
> Accessories and options	
Wall mounting kit	Converter: input IEEE 802.3af/at PoE to 12 or 24 V DC PoE
Cable protection kit	Surge protector for PoE/PoE+/HiPoE ports
Pole mounting kit	Coaxial extension kit for Ethernet / PoE network
Housing opening contact kit	Splice cassette

*SLAT reserves the right to modify the characteristics of its products without prior notice.

Outdoor network interface box created upon request

OUTDOOR



An industrial product designed and assembled for your application, your environment and your equipment.

Specific to the needs for outdoor video applications along with WiFi and Mesh network security requirements.



Your benefits

Entrust the design to our experts:

- ~ 1 order only.
- ~ Pre-assembled product.
- ~ Time saved during your installations.
- ~ Guaranteed smooth operation of the system.
- ~ Peace of mind with the CE marking.
- ~ 2-year global warranty with option to extend.

Benefits of the SYNAPS range

- ~ Eliminates brown-outs and provides emergency power according to your needs.
- ~ Protects equipment against lightning and electromagnetic disturbances.
- ~ Back-up technology - service life ten years.
- ~ Designed for outdoor use, with IP65 watertight and IK10 vandalism-proof locked cabinet.
- ~ Ultra compact and lightweight product.
- ~ Monitoring by secure protocols:
HTTPS / SNMP V1, V2c and V3 / BACnet IP.

Options (mounted)	Benefits
Switch	Ethernet switch: 2 to 8 ports PoE switch: 2 to 4 PoE ports + 1 Ethernet Uplink Managed PoE-Switch: 8 PoE-Ports + 2 SFP-Ports
Power supply	Power supply to connected equipment: total power 55 W - 180 W Filters interference from the electrical grid
Back-up	Built-in emergency power
Mains lightning arrester	Protection up to 40 kA
Load lightning arrester	Protection of Ethernet and PoE/PoE+/HiPoE outlets
Voltage converter	Output voltages 12 / 24 / 36 / 55 V DC
PoE injector	Equipment power supply: PoE / PoE+ / HiPoE (IEEE 802.3af/at/bt) PoE 12 V / PoE 24 V Passive PoE
Media converter	Connection to fibre and coaxial networks
230 V socket	Connecting/plugging in maintenance equipment
Tamper detection	Contact for break-in detection
Extreme Cold	Operation at extremely low outdoor temperature (up to - 40°C)
Splice cassette	Separation of the fiber strands and creation of the splice
Accessories	Benefits
Anti-vandalism kit	Protection against cable cutting
Pole mounting kit	Fixing on a mast/pole or wall

The customised SYNAPS: all the benefits of a standard SYNAPS adapted to your installations.



SLAT BRINGS INNOVATIVE SOLUTIONS TO YOUR TECHNICAL NETWORKS



With the proliferation of information exchange points in the technical networks of buildings, towns and cities or fluid networks, a communication solution is necessary to reduce operational maintenance costs.

SDC products meet this requirement and offer a variety of media and protocols for data exchange. They provide filtering of network disturbances by means of their built-in lithium battery with a 10-year lifespan.

The SDC-PoE range powers the objects connected by the RJ45 cable and ensures their operational maintenance even in the event of a software failure.

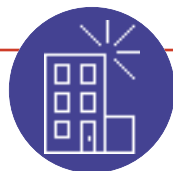
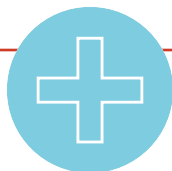
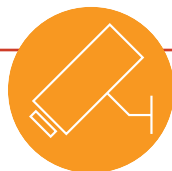

SELECTION GUIDE

	SDC-M RS	SDC-M IP	SDC-PoE	SDC-PoE 4	SDC-PoE 8	SDC-PoE 24
DC output voltage	12V / 24 V / 48 V	12 V / 24 V	55 V	-	-	-
Power	55 W	55 W	55 W	55 W	180 W	210 W
Brown-out protection only	Yes	-	-	-	-	-
Brown-out protection with autonomy (full load)	20 min / 40 min / 1h20	19 min / 1h19	20 min / 1h19	20 min / 39 min	14 min	12 min / 24 min
Switch	-	-	-	unmanaged	managed	managed
Ethernet ports	-	2	1	1	-	-
PoE/PoE+ ports	-	-	1	4	8	Up to 22
HiPoE ports	-	-	-	-	4	-
SFP Ports	-	-	-	-	2	Up to 4
SNMP	-	v1, v2c, v3	v1, v2c, v3	v1, v2c, v3	v1, v2c, v3	v1, v2c, v3
BACnet	MS/TP	IP	IP	IP	IP	IP
Modbus	Up to 115200 bauds	-	-	-	-	-
Page	103	108	112	116	120	125



SDC-M RS



Micro-UPS DC with Modbus / BACnet MS/TP Communication

12 V DC – 24 V DC – 48 V DC



Micro-UPS with "Smart Backup Inside"
and very long service life.



BOX2
285 x 198 x 61 mm



DMR
161 x 92 x 65 mm



DIN1
100 x 124 x 82 mm



DIN2
100 x 124 x 122 mm









Built-in functions

- ~ Maintains the power supply in the event of a power failure or glitch.
- ~ Filters electromagnetic disturbances.
- ~ Avoids erratic operation due to network glitches.
- ~ Delivers a constant voltage to equipment.
- ~ Output voltage adjustable from -8% to +13%.

Key product features

- ~ Ultra-compact / Plug and Play, parallel configuration without accessories.
- ~ Performs self-diagnostic and that of its environment.
- ~ Selection of Modbus or BACnet configuration via a software.
- ~ Highly reliable Supercap or LiFePO4 technology.
- ~ Service life of more than 10 years.



MODEL	WEIGHT (kg)	SIZE W x H x D (mm)	CODE
SDC-M RS 12V			
SDC-M 12V 2D DMR RS	0.5 kg	161 x 92 x 65	81220102
SDC-M 12V 3B DIN1 RS	0.6 kg	100 x 124 x 82	81239112
SDC-M 12V 3D DIN1 RS	0.7 kg	100 x 124 x 82	81230112
SDC-M 12V 3D DIN1 RS DR	0.7 kg	100 x 124 x 82	81230912
SDC-M 12V 3G DIN2 RS	1.4 kg	100 x 124 x 122	81233122
SDC-M 12V 3D BOX2 RS	1.0 kg	285 x 198 x 61	81230212
SDC-M RS 24V			
SDC-M 24V 2D DMR RS	0.5 kg	161 x 92 x 65	81420102
SDC-M 24V 3B DIN1 RS	0.6 kg	100 x 124 x 82	81439112
SDC-M 24V 3D DIN1 RS	0.7 kg	100 x 124 x 82	81430112
SDC-M 24V 3G DIN2 RS	1.4 kg	100 x 124 x 122	81433122
SDC-M RS 48V			
SDC-M 48V 3B DIN1 RS	0.6 kg	100 x 124 x 82	81839112
SDC-M 48V 3D DIN1 RS	0.7 kg	100 x 124 x 82	81830112
SDC-M 48V 3G DIN2 RS	1.4 kg	100 x 124 x 122	81833122
SDC-M 48V 3D BOX2 RS	1.0 kg	285 x 198 x 61	81830212
OPTIONS			
A SETUP KIT SAFE DC RS	-	-	90000002
A KIT BOX2 TAMPER SWITCH	-	-	90000200

> Mechanical characteristics						
Boxes		Size W x H x D (mm)	Weight (kg)	Materials	Protection rating	Installation
	DIN1	100 x 124 x 82	0.44 - 068	Aluminium	IP20	DIN rail
	DIN2	100 x 124 x 122	0.96 - 1.36	Aluminium	IP20	DIN rail
	DMR	161 x 92 x 65	0.5	ABS	IP20	DIN rail
	BOX2	285 x 198 x 61	0.9 - 1.6	ABS	IP30	Wall-mounted
> Connections						
	DIN1	DIN2		DMR		BOX2
Screw terminals with plug-in connectors with polarizing slot.			Two outputs on screw terminals.		- Cable feedthrough via 3 cable glands or cable grommet. - Screw terminals.	
Connections: mains, 1 output, RS485 communication						
Capacity of terminal blocks / Cable size: 0.2 to 2.5 mm ²						
> Standard-based specifications						
<ul style="list-style-type: none"> • EN IEC 62368-1 (2020) + A11 (2020) • EN IEC 61000-6-1 (2019) • EN IEC 61000-6-2 (2019) • EN IEC 61000-3-2 (2019) A class • EN IEC 61000-6-3 (2021) • EN IEC 61000-6-4 (2019) • EN 55032 class B • UN 38.3 				   		
> Environmental specifications						
Temperature						
Storage			-25 to +60°C			
Operating		Lithium Battery	-10 to +55°C at 100% load in normal and backup mode			
		Supercaps	-5 to +55°C at 100% load in battery charge mode			
-40 to +55°C						
Humidity						
Storage			relative humidity 10 to 95%			
Operating			relative humidity 20 to 95%			
Altitude						
100,000 h (with battery) and 200,000 h (without battery) at 25 °C product external environment, rated mains voltage, 75% load						
MTBF						
100,000 h (with battery) and 200,000 h (without battery) at 25 °C product external environment, rated mains voltage, 75% load						
> Electrical characteristics						
Network input						
Voltage network AC			99 to 264 V AC			
Voltage network DC			140 to 375 V DC			
Frequency			45 to 65 Hz			
Class			Class 1			
Current			Inrush current limited by NTC			
Neutral systems			TT, TN, IT			
Protection against			primary short circuit and differential mode shock waves.			
Primary current @ 99 V AC			0.8 A [30 W] ; 1.5 A [55 W]			
Primary current @ 264 V AC			0.8 A [30 W] ; 0.38 A [55 W]			

> Operating output			
Rated voltage (U _n)	12 V DC	24 V DC	48 V DC
Output current (I _n) 30 W	2.5 A	1.25 A	-
Output current (I _n) 55 W	4.6 A	2.3 A	1.15 A
Maximum output power	30 W / 55 W		
Precision on voltage	1%		
Adjustment by potentiometer [55 W]	-8% to +13%		
Current limitation – short-circuit current	P _{max} to P _{max} +10% with output voltage > 6 V		
Peak current	2 I _n during 0.004 second		
HF ripple peak-peak (20 MHz-50 Ω)	< 4% of U _n		
Effective LF ripple	< 0.5% of U _n		
Static and dynamic regulation characteristics	< 5% of U _n for cumulative changes in sector and load (from 10% to 90%)		
Output (Smart Backup)	η @ 20% loading	η @ 75% loading	η @ 100% loading
	90%	93%	92%

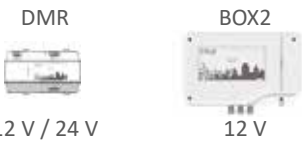
> Functional characteristics			
Operates in power-saving mode when the backup is charged.			
Remote controlled stealth mode.			
Filters disturbances of the electrical network.			
Indicates the % of remaining autonomy.			
(not for 48 V) Parallel configuration without accessories for: power increase / increase of the backup / redundancy.			
Push-button disconnect of the backup (reset).			
Smart backup			
Backup type 55W	3B	3D	3E
Latest generation Lithium LiFePO4 technology: 2D, 3D, 3E, 3G - for back-up time, see table below.			
Back-up 3B - SuperCap technology with a back-up time of 3 seconds at 100% load - 500 000 cycles.			
Storage: 9 months without recharging.			
10 years service life.			
Advanced management settings, cell balancing, overload and overvoltage protection.			
Protection against deep discharge.			
A front panel pushbutton (on the board for BOX2) disconnects the backup via a static switch. The battery is automatically reconnected when mains voltage is present.			

Backup duration according to output power - 30 W (Type 2)	
	 DMR BOX2 12 V / 24 V 12 V
	Backup 2D
Operating power	Autonomy expressed in hours and minutes
5 W	3h23
7 W	2h32
10 W	1h48
15 W	1h13
20 W	0h55
25 W	0h44
30 W	0h36

Backup duration according to output power - 55 W (Type 3)				
	 DIN1 12 V / 24 V / 48 V	 DIN1 12 V / 24 V / 48 V BOX2 12 V / 24 V / 48 V	 DIN2 12 V / 24 V / 48 V BOX2 12 V / 24 V / 48 V	
	Backup 3B	Backup 3D	Backup 3E	Backup 3G
Operating power	Autonomy expressed in hours and minutes			
5 W	Minimum 3 seconds	3h10	6h20	12h40
7 W		2h24	4h48	9h36
10 W		1h46	3h31	7h02
15 W		1h13	2h25	4h49
20 W		0h55	1h50	3h40
25 W		0h44	1h28	2h56
30 W		0h37	1h14	2h27
35 W		0h32	1h03	2h06
40 W		0h28	0h55	1h50
45 W		0h25	0h49	1h39
50 W		0h22	0h44	1h28
55 W		0h20	0h40	1h20
Protections				
Against overvoltages on primary (atmospheric or industrial causes) by varistor and filter.				
Against surges in user output (connection error) by breaking with cyclical restart if output voltage > U _n +10%.				
Against overcurrent by limiting the power supply to P _n +10%.				
Against output short-circuits by disconnecting the power supply with cyclical restart.				
MMI				
LED for status display and control				
Permanent green	Flashing green	Slow flashing orange	Fast flashing orange	Red
Normal mode	ECO mode Stealth mode	Backup mode	Installation fault - Overcurrent, short circuit. - Low voltage output (product overload). - Excessive power supply temperature - If no mains (outside specified power supply range) End of backup imminent	UPS to be changed - If no output voltage. - If power supply out of order (charger fault). Battery fault - Backup undervoltage. - Backup overvoltage.
Communication				
A RS485 type serial link retrieves information remotely (product serial number, system status) and communicates the analog values (voltages and load current, % of remaining backup, rectifier, and internal temperature of the DC UPS).				
The on-board Modbus communication protocol is factory set. it may can be configured in BACnet protocol via the configuration software that can be downloaded on www.slat.com (setup details in the manual).				
1 dry contact (open collector): 60 V DC / 1.1 A				
> Product references				
Interpretation of the product reference designations: SDC-M [Voltage] [Backup] [Box] RS				

*SLAT reserves the right to modify the characteristics of its products without prior notice.

SDC-M IP

DC Micro-UPS, SNMP / BACnet IP Protocols

12 V DC – 24 V DC



Micro-UPS with Smart Backup Inside
and long service life.



BOX2
285 x 198 x 61 mm



DIN1
100 x 124 x 82 mm



DIN2
100 x 124 x 122 mm







Built-in functions

- ~ Backup LiFePO4 inside with very long life.
- ~ Reboot function available.
- ~ Open protocols HTTPS / SNMP / BACnet IP.
- ~ Closely securises IP applications' functions in case of a power cut.
- ~ Delivers a constant voltage to equipment, adjustable via HTTPS website, from -8% to +13%.





Key product features

- ~ Ultra-compact / Plug and Play.
- ~ Performs self-diagnostic and that of its environment.
- ~ Saves wiring.
- ~ 2 Ethernet ports protected against glitches.

MODEL	WEIGHT (kg)	SIZE W x H x D (mm)	CODE
SDC-M IP 12V			
SDC-M 12V 3D DIN1 IP	0.7 kg	100 x 124 x 82	81230113
SDC-M 12V 3G DIN2 IP	1.4 kg	100 x 124 x 122	81233123
SDC-M 12V 3D BOX2 IP	1.0 kg	285 x 198 x 61	81230213
SDC-M IP 24V			
SDC-M 24V 3B DIN1 IP	0.6 kg	100 x 124 x 82	81439113
SDC-M 24V 3D DIN1 IP	0.7 kg	100 x 124 x 82	81430113
SDC-M 24V 3G DIN2 IP	1.4 kg	100 x 124 x 122	81433123
SDC-M 24V 3D BOX2 IP	1.0 kg	285 x 198 x 61	81430213
OPTIONS			
A KIT BOX2 TAMPER SWITCH	-	-	90000200

> Mechanical characteristics						
Boxes		Size W x H x D (mm)	Weight (kg)	Materials	Protection rating	Installation
	DIN1	100 x 124 x 82	0.68	Aluminium	IP20	DIN Rail
	DIN2	100 x 124 x 122	0.96 - 1.36	Aluminium	IP20	DIN Rail
	BOX2	285 x 198 x 61	1 - 1.6	ABS	IP30	Wall-mounted
Connections						
		DIN1	DIN2	BOX2		
- 2 Screw terminals with plug-in connectors with polarizing slot. (Input 110 / 230 V AC, 1 output 12-24 V DC) - 2 RJ45 ports 100 Mbps.				- Cable feedthrough via 3 cable glands. - 2 Screw terminals on the PC board: input 110 / 230 V AC, 1 output 12-24 V DC - 2 RJ45 ports 100 Mbps (on the PC board).		
Network cables: Ethernet cable Cat 5 or more / shielded or unshielded / straight or twisted						
> Standard-based specifications						
<ul style="list-style-type: none"> • EN IEC 62368-1 (2020) + A11 (2020) • EN IEC 61000-6-1 (2019) • EN IEC 61000-6-2 (2019) • EN IEC 61000-3-2 (2019) A class • EN IEC 61000-6-3 (2021) • EN IEC 61000-6-4 (2019) • EN 55032 class B • UN 38.3 Ethernet IEEE 802.3, IEEE 802.3u, IEEE 802.3x, IEEE 802.3az (Energy Efficient Ethernet EEE)				   		
> Environmental specifications						
Temperature						
Storage			-20 to +45°C			
Operating		Lithium Battery	-10 to +55°C at 100% load in normal and backup mode			
		Supercaps	-5 to +55°C at 100% load in battery charge mode			
		Supercaps	40°C to +55°C			
Humidity						
Storage			relative humidity 10 to 95%			
Operating			relative humidity 20 to 95%			
Altitude						
Above 2,000 m, the maximum operating temperature decreases by 5% every 1,000 m						
MTBF						
100,000 h (with battery) and 200,000 h (without battery) at 25 °C product external environment, rated mains voltage, 75% load						
> Electrical characteristics						
Network input						
Voltage network AC			99 to 264 V AC			
Voltage network DC			140 to 375 V DC			
Frequency			45 to 65 Hz			
Class			Class 1			
Current			Inrush current limited by NTC			
Neutral systems			TT, TN, IT			
Protection against			Primary short circuit and differential mode shock waves.			
Primary current @ 99 V AC			1.5 A			
Primary current @ 264 V AC			0.38 A			

Operating output			
Rated voltage (U_n)	12 V DC		24 V DC
Output current (I_n)	4.6 A		2.3 A
Maximum output power	55 W		
Precision on voltage	1%		
Adjustment via HTTPS interface	-8% to +13%		
Power limitation	P_{max} to $P_{max} +10\%$ with output voltage > 6 V		
Peak current	2 I_n for 0,012 second		
HF ripple peak-peak (20 MHz-50 Ω)	< 1.9% of U_n		
Effective LF ripple	< 0.3% of U_n		
Static and dynamic regulation characteristics	< 7% of U_n for cumulative changes in sector and load (from 10% to 90%)		
Output (Smart Backup)	η @ 20% loading	η @ 75% loading	η @ 100% loading
	85%	91%	90%
> Functional characteristics			
Operates in power-saving mode when the backup is charged.			
Remote controlled stealth mode.			
Filters disturbances of the electrical network.			
Fanless.			
Reboot function (start and stop automatically) available.			
Indicates the % of remaining autonomy.			
Parallel configuration without accessories for: power increase / increase of the backup time / redundancy.			
Disconnection of the backup via a pushbutton (reset).			
Smart backup			
SDC-M IP exists in 2 backup packs	3B	3D	3G
Latest generation LiFePO4 Lithium Technology: Backup 3D, 3G - for back-up time, see table below.			
Backup 3B - Supercaps technology with a backup time of minimum 3 seconds at 100% load - 500 000 cycles.			
Lead-free, cadmium-free, 100% recyclable.			
Storage: 9 months without recharging.			
10 years service life.			
Advanced management settings, cell balancing, overload and overvoltage protection.			
Protection against deep discharge.			
A front panel pushbutton (on the board for BOX2) disconnects the backup via a static switch. The backup is automatically reconnected when mains voltage is present.			
Protections			
Against overvoltages on primary (atmospheric or industrial causes) by varistor and filter.			
Against surges in user output (connection error) by breaking with cyclical restart if output voltage > $U_n +10\%$.			
Against overcurrent by limiting the power supply to $P_n +10\%$.			
Against output short-circuits by disconnecting the power supply with cyclical restart.			

Backup duration according to output power				
	 DIN1 24 V	 DIN1 12 V / 24 V	 DIN2 12 V / 24 V	
	 BOX2 12 V / 24 V		 BOX2 12 V / 24 V	
	Backup 3B	Backup 3D	Backup 3G	
Operating power	Autonomy expressed in hours and minutes			
5 W	Minimum 3 seconds	2h54	11h38	
7 W		2h15	9h	
10 W		1h40	6h42	
15 W		1h10	4h40	
20 W		0h53	3h33	
25 W		0h43	2h52	
30 W		0h36	2h24	
35 W		0h31	2h04	
40 W		0h27	1h48	
45 W		0h24	1h37	
50 W		0h21	1h27	
55 W		0h19	1h19	
MMI				
LED for status display and control (UPS DC Status)				
Steady green	Flashing green	Slow flashing orange	Fast flashing orange	Red
Normal mode	ECO mode Stealth mode	Backup mode	Installation fault - Overcurrent, short circuit - Low voltage output (product overload). - Excessive power supply temperature - If no mains (outside specified power supply range). End of backup imminent	UPS to be changed - If no output voltage - If power supply out of order (charger fault). Backup fault - Backup undervoltage. - Backup overvoltage
LEDs indicators for each Ethernet port status (Link/Act)				
Steady green		Flashing Green		
Connected		- Connected - Ethernet link status		
Communication				
2 ports 100 Mbps available to connect the DC Micro-UPS to Ethernet Network and remote information (serial number, system status), analog values monitoring (output voltage and current, % backup time, mains status, internal temperature), and parameters setup with on-board HTTPS website.				
Auto MDI/MDI-X	yes			
MAC Adress	8,000 address			
Data Transfer Method	Store & Forward			
Data Transfer Rate	650 Mbps			
Frame size and delay (max)	1 518 octets / 126 μs			
Update program	Upgrade via HTTPS web browser			
Supported Protocols: IPv4, HTTPS, TCP, UDP, ICMP, ARP,DHCP, SNMP V1 & V3, BACnet IP.				
> Product references				
Interpretation of the product reference designations: SDC-M [Voltage] [Backup] [Box] IP				

*SLAT reserves the right to modify the characteristics of its products without prior notice.

SDC-PoE

PoE Micro-UPS, Protocols SNMP / BACnet IP

PoE / PoE+ (IEEE 802.3 af/at)



DC Micro-UPS, with integrated backup function,
with a very long service life.



DIN1
100 x 124 x 82 mm



DIN2
100 x 124 x 122 mm

Built-in functions



- ~ Powers all PoE / PoE + equipment.
- ~ PoE 30 W budget.
- ~ Integrated LiFePO4 backup, with a very long service life.
- ~ Configurable reboot function.
- ~ HTTPS / SNMP / BACnet IP open communication protocols.

Key product features

- ~ Ultra-compact & plug-and-play.
- ~ Performs self-diagnostic and that of its environment
- ~ 1 secured PoE output
- ~ Operates as IP power supply: Max. power on terminal 55 W

MODEL	WEIGHT (kg)	SIZE W x H x D (mm)	CODE
SDC-PoE			
SDC-POE 3D DIN1 P1	0.7 kg	100 x 124 x 82	83930933
SDC-POE 3G DIN2 P1	1.4 kg	100 x 124 x 122	83933933

> Mechanical characteristics						
Boxes		Size W x H x D (mm)	Weight (kg)	Materials	Protection rating	Installation
	DIN1	100 x 124 x 82	0.68	Aluminium	IP20	DIN Rail
	DIN2	100 x 124 x 122	1.36	Aluminium	IP20	DIN Rail
Connections						
DIN1			DIN2			
<p>- 2 screw terminals with plug-in connectors with polarizing slot. (Input 110 / 230 V AC, 1 output 55 V DC).</p> <p>- 1 RJ45 port 100 Mbps.</p> <p>- 1 PoE/PoE+ port 100 Mbps.</p>						
Network cable: Ethernet cable Cat 5 or more / shielded or unshielded / straight or twisted						
> Standard-based specifications						
<ul style="list-style-type: none"> • EN IEC 62368-1 (2020) + A11 (2020) • EN IEC 61000-6-1 (2019) • EN IEC 61000-6-2 (2019) • EN IEC 61000-3-2 (2019) A class • EN IEC 61000-6-3 (2021) • EN IEC 61000-6-4 (2019) • EN 55032 class B • UN 38.3 • IEEE 802.3af/at 				   		
Ethernet IEEE 802.3, IEEE 802.3u, IEEE 802.3x, IEEE 802.3az (Energy Efficient Ethernet EEE)						
> Environmental specifications						
Temperature						
Storage			-20 à +45°C			
Operating			-10 to +55°C at 100% load in normal and backup mode			
			-5 to +55°C at 100% load in battery charge mode			
Humidity						
Storage			relative humidity 10 to 95%			
Operating			relative humidity 20 to 95%			
Altitude						
Above 2,000 m, the maximum operating temperature decreases by 5% every 1,000 m						
MTBF						
100,000 h (with battery) and 200,000 h (without battery) at 25 °C product external environment, rated mains voltage, 75% load						
> Electrical characteristics						
Network input						
Voltage network AC			99 to 264 V AC			
Voltage network DC			140 to 375 V DC			
Frequency			45 à 65 Hz			
Class			Class 1			
Current			Inrush current limited by NTC			
Neutral systems			TT, TN, IT			
Protection against			primary short circuit and differential mode shock waves.			
Primary current @ 99 V AC			1.5 A			
Primary current @ 264 V AC			0.38 A			

Operating output			
PoE technology	IEEE 802.3 af, IEEE 802.3 at, PSE of type B		
Budget PoE on RJ45 port	30 W		
Maximum power on terminal block and PoE	55 W at 55 V		
Output (Smart Backup)	η @ 20% loading	η @ 75% dloading	η @ 100% loading
	85%	91%	90%
> Functional characteristics			
Operates in power-saving mode when the backup is charged.			
On/Off function per port.			
Filters disturbances of the electrical network.			
Fanless.			
Reboot function (start and stop automatically) available.			
Indicates the % of remaining autonomy.			
Disconnection of the backup via a pushbutton (reset).			
Smart backup			
SDC-PoE is available in 2 backup packs	3D		3G
Latest generation Lithium LiFePO4 Technology (no risk of thermal runaway).			
Lead-free, cadmium-free, 100% recyclable.			
Storage: 9 months without recharging.			
10 year service life.			
Advanced management settings, cell balancing, overload and overvoltage protection.			
A front panel pushbutton (on the board for BOX2) disconnects the backup via a static switch. The backup is automatically reconnected when mains voltage is present.			
Backup duration according to output power - 55 W (Type 3)			
	 Backup 3D		 Backup 3G
Operating power	Autonomy expressed in hours and minutes		
5 W	2h49	11h14	
7 W	2h11	8h46	
10 W	1h39	6h34	
15 W	1h09	4h36	
20 W	0h53	3h32	
25 W	0h43	2h51	
30 W	0h36	2h23	
35 W	0h31	2h04	
40 W	0h27	1h48	
45 W	0h24	1h37	
50 W	0h22	1h27	
55 W	0h20	1h19	

Protections				
Against overvoltages on primary (atmospheric or industrial causes) by varistor and filter.				
Against surges in user output (connection error) by breaking with cyclical restart if output voltage > $U_n + 10\%$.				
Against overcurrent by limiting the power supply to $P_n + 10\%$.				
Against output short circuits by disconnecting the mains by cyclical restart.				
Against overcurrent and short-circuits by disconnecting the PoE port to $I > I_n + 10\%$.				
MMI				
LED for status display and control (UPS DC status).				
Steady green	Flashing green	Slow flashing orange	Fast flashing orange	Red
Normal mode	ECO mode Stealth mode	Backup mode	Installation fault - Overcurrent, short circuit - Low voltage output (product overload). - Excessive power supply temperature - If no mains (outside specified power supply range). End of backup imminent	UPS to be changed - If no output voltage - If power supply out of order (charger fault). Backup fault - Backup undervoltage. - Backup overvoltage
LEDs to give the status of the Ethernet port activity (Link / Act)				
Steady green		Flashing green		
Connection established		- Connection established - Activity on the Ethernet link		
LED to give the status of the PoE / PoE + power supply				
Steady orange		Off		
PoE active		- PoE inactive - PoE waiting for a connection		
Communication				
2 ports 100 Mbps allow to connect the Micro UPS DC to an Ethernet network to check information remotely (product serial number, system status), to communicate analog values (voltage and operating current, % remaining backup, power supply status, internal temperature of the UPS DC) and to configure its settings via on-board HTTPS webserver.				
Auto MDI/MDI-X	yes			
MAC address table	8,000 address			
Transmission method	Store & Forward			
Transmission capacity	650 Mbps			
Frame size and latency (max)	1 518 octets / 126 μ s			
Improved version of the micro program	Upgrade via HTTPS web browser			
Protocols supported: IPv4, HTTPS, TCP, UDP, ICMP, ARP, DHCP, SNMP V1 & V3, BACnet IP.				
> Product references				
Interpretation of the product reference designations: SDC-POE [Backup] [Box] P1				

*SLAT reserves the right to modify the characteristics of its products without prior notice.

SDC-PoE 4



Edge switch with 4 PoE+ ports,, backed up by integrated Micro-UPS
SNMP / BACnet IP protocols

PoE / PoE+ (IEEE 802.3af/at)



4-port PoE+ switch, 15 min to 5h emergency function integrated,
with very long service life



BOX2
285 x 198 x 61 mm







Built-in functions

- ~ Secures up to 4 PoE / PoE+ devices
- ~ PoE 55 W budget
- ~ 15 min to 5h integrated backup
- ~ Integrated LiFePO4 backup, with very long service life
- ~ Configurable reboot function for each port
- ~ HTTPS / SNMP / BACnet IP open communication protocols.

Key product features

- ~ Protects PoE equipment against any electrical disturbance, internal or external
- ~ Ultra-compact & plug-and-play
- ~ Performs self-diagnostic and that of its environment
- ~ Saves wiring
- ~ 4 protected Ethernet ports 100 Mbps / 1 protected Ethernet port 1 Gbps.

MODEL	WEIGHT (kg)	SIZE W x H x D (mm)	CODE
SDC-PoE 4			
SDC-POE 3D BOX2 P4	1.0 kg	285 x 198 x 61	83930924

> Mechanical characteristics							
Boxes	Size W x H x D (mm)	Weight (kg)	Materials	Protection rating	Installation		
 BOX2	285 x 198 x 61	1.1 - 1.3	ABS	IP30	Wall mounted / Shelf placement		
Connections							
<ul style="list-style-type: none"> - 1 power cable to be connected to the 110 / 230 V AC mains. - 1 RJ45 port 1000 Mbps. - 4 PoE/PoE+ ports 100 Mbps. 							
Network cable: Ethernet cable Cat 5 or more / shielded or unshielded / straight or twisted							
> Standard-based specifications							
<ul style="list-style-type: none"> • EN IEC 62368-1 (2020) + A11 (2020) • EN IEC 61000-6-1 (2019) • EN IEC 61000-6-2 (2019) • EN IEC 61000-3-2 (2019) A class • EN IEC 61000-6-3 (2021) • EN IEC 61000-6-4 (2019) • EN 55032 class B • UN 38.3 • IEEE 802.3af/at Ethernet IEEE 802.3i, IEEE 802.3u, IEEE 802.3x, IEEE 802.3az (Energy Efficient Ethernet EEE) 							
> Environmental specifications							
Temperature							
Storage	-20 à +45°C						
Operating	-10 to +55°C at 100% load in normal and backup mode						
	-5 to +55°C at 100% load in battery charge mode						
Humidity							
Storage	relative humidity 10 to 95%						
Operating	relative humidity 20 to 95%						
Altitude							
Above 2,000 m, the maximum operating temperature decreases by 5% every 1,000 m							
MTBF							
100,000 h (with battery) and 200,000 h (without battery) at 25 °C product external environment, rated mains voltage, 75% load							
> Electrical characteristics							
Network input							
Voltage AC network	99 to 264 V AC						
Voltage DC network	140 to 375 V DC						
Frequency	45 to 65 Hz						
Class	Class 1						
Current	Inrush current limited by NTC						
Neutral systems	TT, TN, IT						
Protection against	primary short circuit and differential mode shock waves.						
Primary current @ 99 V AC	1.5 A						
Primary current @ 264 V AC	0.38 A						
Operating output							
PoE technology	IEEE 802.3 af, IEEE 802.3 at, PSE of type B						
Budget PoE max per RJ45 port	30 W						
Total PoE budget	55 W to 55 V						
Management of port priority	no						
Output (Smart Backup)	η @ 20 % loading	η @ 75 % loading	η @ 100 % loading				
	85%	91%	90%				

> Functional characteristics		
Operates in power-saving mode when the backup is charged.		
On/Off function per port.		
Filters disturbances of the electrical network.		
Without fan.		
Configurable reboot function (stops and restarts automatically) on each port.		
Indicates the % of the remaining autonomy.		
Disconnection of the backup via a pushbutton (reset).		
Smart backup		
SDC-PoE 4 is available in 2 backup packs	3D	3E
Latest generation Lithium LiFePO4 Technology (no risk of thermal runaway).		
Lead-free, cadmium-free, 100% recyclable.		
Storage: 9 months without recharging.		
10 year service life.		
Advanced management settings, cell balancing, overload and overvoltage protection.		
A push button on the board disconnects the backup via a static switch. The backup is automatically reconnected when mains voltage is present		
Protections		
Against overvoltages on primary (atmospheric or industrial causes) by varistor and filter.		
Against overvoltage on output terminals (control failure or cabling error) by disconnection and automatic restart when output voltage exceeds $U_n + 10\%$		
Against overload by power limitation to $P_n + 10\%$.		
Against short-circuits on output terminals by disconnection with cyclical restart.		
Against overcurrent and short-circuits by disconnecting the PoE port at $I > I_n + 10\%$.		
Backup duration according to output power - 55 W (TYPE 3)		
Operating power	Backup 3D	Backup 3E
	Autonomy expressed in hours and minutes	
5 W	2h31	5h01
7 W	2h	4h
10 W	1h32	3h04
15 W	1h06	2h12
20 W	0h51	1h42
25 W	0h42	1h23
30 W	0h35	1h10
35 W	0h30	1h
40 W	0h27	0h53
45 W	0h24	0h47
50 W	0h21	0h43
55 W	0h20	0h39

MMI				
LED for status display and control (UPS DC status).				
Steady green	Flashing green	Slow flashing orange	Fast flashing orange	Red
Mode normal	ECO mode Stealth mode	Backup mode	Installation fault - Overcurrent, short circuit - Low voltage output (product overload). - Excessive power supply temperature - No mains (outside specified power supply range). End of backup imminent	UPS to be changed - If no output voltage - If power supply out of order (charger fault). Backup fault - Backup undervoltage. - Backup overvoltage
LEDs to give the status of the Ethernet port activity (Link / Act)				
Steady green		Flashing green		
Connection established		- Connection established - Activity on the Ethernet link		
LED to give the status of the PoE / PoE + power supply				
Steady orange		Off		
PoE active		- PoE inactive - PoE waiting for a connection		
Communication				
1 port 1,000 Mbps makes it possible to connect the end switch to the Ethernet network (or for local diagnosis) in order to consult information remotely (product serial number, system status), to communicate analog values (voltage and load current, % of backup remaining, power status, internal temperature of the UPS DC) and to configure its settings via the on-board HTTPS webserver.				
Auto MDI/MDI-X	yes			
MAC address table	8,000 entries			
Transmission method	Store & Forward			
Intern switch capacity	650 Mbps			
Frame size and latency (max)	1 518 octets / 126 µs			
Improved version of the micro program	Upgrade via HTTPS web browser			
Protocols supported: IPv4, HTTPS, TCP, UDP, ICMP, ARP, DHCP, SNMP V1 & V3, BACnet IP.				
> Product references				
Interpretation of the product reference designations: SDC-POE [Backup] BOX2 P4				

*SLAT reserves the right to modify the characteristics of its products without prior notice.

SDC-PoE 8



Managed 8 port HiPoE Switch + 2 optical fibers, full Gigabit layer 2
Secured by an integrated micro-UPS, secure protocols



PoE/PoE+/HiPoE (IEEE 802.3bt)

SDC-PoE 8 powers cameras, LPUs and systems. It ensures the access control and video stream security 24/7.



Built-in functions

- ~ Supplies power to up to 8 PoE/PoE+/HiPoE devices
- ~ Manages the data and video flow
- ~ Two independent optical fiber connections
- ~ Contains a micro-UPS
- ~ Eliminates micro-cuts and brown outs
- ~ Reboots automatically the monitored devices
- ~ One programmable dry contact output and input
- ~ Web server monitoring of the complete system and the connected devices

Key product features

- ~ Many security features to preserve all video and data flows
- ~ Ensures the operation of the systems in case of vandalism
- ~ Prevents interventions to reset cameras
- ~ Operates for 10 years without maintenance
- ~ Maintains applications operational 24/7
- ~ Saves space and implementation time

MODEL	WEIGHT (kg)	SIZE W x H x D (mm)	CODE
SDC-PoE 8			
SDC-POE 5F DIN4 8P2F	2.2	215 x 138 x 148	83952145



SNMP / BACnet IP communication

SDC-PoE 8 is a PoE/PoE+/HiPoE managed layer 2 switch, with a built-in micro-UPS function (LiFePO4 battery). With 10 full-Gigabit ports including 4 HiPoE, 4 PoE+ and 2 SFP for fiber links, the switch interconnects and supplies equipments, such as cameras, recorders, alarm panels, etc... It manages data or video flows and monitors the proper functioning of the devices. In the event of a power failure, it ensures service continuity and maintains operation of the equipments powered by PoE.

> Mechanical characteristics					
Boxes	Size W x H x D (mm)	Weight (kg)	Materials	Protection rating	Installation
DIN 4 	215 x 138 x 131 (without connectors)	2.2	Aluminium	IP20	DIN rail
Connections					
Mains	Screw terminal with plug-in connector with polarizing slot				
PoE ports	8 RJ45 ports	Ethernet cable Category 5e or more (PoE/PoE+)/ Category 6a or more (HiPoE) shielded, straight or twisted cables			
SFP ports	2 SFP ports	SFP module 1000 Mbps transceiver			
Digital Input/ Dry Contact	Screw terminal with plug-in connector with polarizing slot				
> PoE					
PoE/PoE+/HiPoE Ports	4 Ports, End-span cabling (Mode A) IEEE 802.3af/at/bt - 15 W / 30 W / 60 W / 90 W per port				
PoE/PoE+ Ports	4 Ports, End-span cabling (Mode A) IEEE 802.3af/at - 15 W / 30 W per port				
Power	PoE function configuration per port				
PoE budget	180 W				
> Communication					
Communication speed	PoE ports	10 / 100 / 1000 Mbps			
	SFP ports	100 / 1000 Mbps			
Application layer protocols	HTTPS, BACnet IP, SNMP (v1, v2c, v3), DHCP				
Network layer protocols	IPv4, ICMP				
> Switch properties					
Priority Queues	8				
Max. Number of VLANs	4094				
VLAN ID Range	VID 1 to 4094				
IGMP Groups	1024				
MAC Table Size	Up to 8K MAC addresses				
Jumbo Frame Size	9.6 KB				
Performance					
Capacity of the forwarding rate in Millions of Packets per Second (Mpps) (64-byte packets)	14.88 Mpps				
Switching Capacity in Gigabits per Second (Gbps)	20 Gbps				

> Switching characteristics	
Layer 2 Switching	
Spanning Tree Protocol (STP)	Standard Spanning Tree (STP) IEEE 802.1D
	Rapid Spanning Tree (RSTP) IEEE 802.1w
Aggregation	Link Aggregation Control Protocol (LACP) IEEE 802.3ad; Up to 5 groups, up to 8 ports per group
VLAN	Supports up to 4K VLANs simultaneously (out of 4094 VLAN IDs); Port-based VLAN; 802.1Q tag-based VLAN
IGMP v1/v2 Snooping	IGMP limits bandwidth-intensive multicast traffic to only the requesters; it supports 1024 multicast groups (source-specific multicasting is also supported)
Security	
Secure Sockets Layer (SSL), HTTPS	SSL encrypts the http traffic, allowing advance secure access to the browser-based management GUI in the switch
Port Security	Locks MAC Addresses to ports, and limits the number of learned MAC addresses
IP Source Guard	Prevents datagram with spoofed addresses from being in the network
Storm control	Prevents traffic on a LAN from being disrupted by a broadcast, multicast or unicast storm on a port
ACLs	Supports for up to 256 entries; Drop or rate limitation based on source and destination MAC, VLAN ID or IP address, protocol, port, differentiated services code point (DSCP) / IP precedence, TCP/ UDP source and destination ports, 802.1p priority, Ethernet type, Internet Control Message Protocol (ICMP) packets, IGMP packets, TCP flag
Quality of Service	
Hardware Priority Queue	Supports 8 hardware queues
Scheduling	Strict priority and weighted round-robin (WRR)
	Queue assignment based on DSCP and class of service (802.1p/ CoS)
Classification	Port based; 802.1p VLAN priority based; IPv4 precedence/ type of service (ToS) / DSCP based
Rate Limiting	Ingress policer; egress shaping and rate control; per VLAN, per port and flow based
Management (Web/SSL, SNMP, BACnet)	
Web GUI interface	Built-in switch configuration utility for browser-based device configuration (HTTPS). Supports configuration, system dashboard, maintenance and monitoring.
Firmware upgrade	Web browser upgrade (HTTPS)
Port mirroring	Traffic on a port can be mirrored to another port for analysis with a network analyzer or RMON probe. Up to N-1 (N is Switch's Ports) ports can be mirrored to a single destination port. A single session is supported.
Other management	Single IP management; HTTPS; RADIUS; DHCP Client; SNTP; cable diagnostics
Green Ethernet	
Link detection	Compliant IEEE802.3az Energy Efficient Ethernet Task Force. Automatically turns off power on Gigabit Ethernet RJ45 port when detecting link down or Idle of client. Active mode is resumed without loss of any packets when the switch detects the link up.
Cable length detection	Adjusts the signal strength based on the cable length. Reduces the power consumption for shorter cables.
Eco Mode	Shifts automatically to power-saving mode.
Discovery	
Link Layer Discovery Protocol (LLDP)	Used by network devices for advertising their identities, capabilities and neighbors on a IEEE 802 local area network, principally wired Ethernet.
The configuration of the switch functions is done via the embedded website.	

> Signaling	
1 LED for the "PoE Load" level on the front panel	
1 LED for the product "Status" on the front panel	
8 LEDs indicate the PoE activity on the corresponding port (green)	
8 LEDs indicate the data transmission activity on the corresponding port (yellow)	
> Environmental specifications	
Temperature	
Storage	-20°C à +45°C
Operating	at 100% load: -10°C ... +45°C
	at 75% load: -10°C ... +50°C
Humidity	
Storage	relative humidity 10% ... 90%
Operating	relative humidity 20% ... 85%
Altitude	
Above 2,000 m, the temperature decreases by 5% every 1,000 m.	
Cooling	
The cooling is carried out transversally.	
MTBF	
100,000 h (with battery) and 200,000 h (without battery) at 25 °C product external environment, rated mains voltage, 75% load	
> Electrical characteristics	
Network Input	
AC network voltage	198 to 264 V AC
Frequency	45 to 65 Hz
Class	1
Inrush current	Limited by NTC
Neutral system	TT, TN, IT
Protection against	primary short-circuit and differential mode shock waves
Primary current @ 198 V	1.85 A
Primary current @ 264 V	1.70 A
Functional characteristics	
Operates in power-saving mode when the backup is charged.	
On/Off function per PoE port.	
Filters disturbances of the electrical network.	
Fan-cooling.	
Configurable reboot function (stop and restart automatically) on each PoE-port.	
Indicates the % of the remaining autonomy.	
Protections	
Against surge and overvoltage on primary (Lightning or industrial origins).	
Against overload by power limitation to Pn+10%.	
Against overcurrent and short-circuits on the output by disconnecting the PoE port at I > In + 10%.	
Smart backup	
SDC-PoE 8 is available with the backup pack	5F
Latest generation Lithium LiFePO4 Technology (no risk of thermal runaway).	
Lead-free, cadmium-free, 100% recyclable.	
Storage: 9 months without recharging.	
10 year service life.	
Advanced management settings, cell balancing, overload and overvoltage protection.	

Backup duration according to output power	
Operating power	Backup F Autonomy expressed in hours and minutes
10 W	2h07
20 W	1h29
30 W	1h09
40 W	0h55
50 W	0h46
60 W	0h40
70 W	0h35
80 W	0h31
90 W	0h28
100 W	0h25
110 W	0h23
120 W	0h21
130 W	0h20
140 W	0h18
150 W	0h17
160 W	0h16
170 W	0h15
180 W	0h14
> Standards	
IEEE Standards	
IEEE 802.1D	Standard Spanning Tree / Multicast
IEEE 802.1w	Rapid Spanning Tree (RSTP)
IEEE 802.1Q	VLAN
IEEE 802.1X	Radius
IEEE 802.3ad	Link Aggregation Control Protocol (LACP)
IEEE 802.3i	10BaseT
IEEE 802.3u	100BaseT(X) and 100BaseFX
IEEE 802.3ab	1000BaseT(X)
IEEE 802.3z	1000BaseX
IEEE 802.3x	Flow Control
IEEE 802.3af	PoE
IEEE 802.3at	PoE+
IEEE 802.3bt	HiPoE (type 3 & 4)
IEEE 802.3az	Energy Efficient Ethernet
Electrical standards	
Safety	• EN IEC 62368-1 (2020) + A11 (2020)
EMC - Immunity	• EN IEC 61000-6-1 (2019) • EN IEC 61000-6-2 (2019)
EMC - Emissions	• EN IEC 61000-6-3 (2021) • EN IEC 61000-6-4 (2019)
	• EN IEC 61000-3-2 (2019) (class A)
	• EN 55032 (2015) (class B)
   	
Security standards	
Transportation security	• UN 38.3
> Product references	
SDC-POE 5F DIN4 8P2F	

*SLAT reserves the right to modify the characteristics of its products without prior notice.

SDC-POE 24

Layer 2 switch for access control and video surveillance

PoE / PoE+ (IEEE 802.3af/at)



24 port full Gigabit managed PoE / PoE+ switch, secured by an integrated micro-UPS. Secure protocols.

SDC-PoE 24 powers systems, LPU's and cameras, ensures the access and video stream security 24/7.



RACK 2U

446 x 85 x 380 mm



Build-in functions

- ~ Supplies power to up to 22 PoE / PoE+ devices
- ~ Manages the data and video flows
- ~ Allows connections by optical fiber
- ~ Contains a micro-UPS
- ~ Eliminates line disturbances
- ~ Reboots automatically the monitored devices

Key product features

- ~ Many security features to preserve all data flow
- ~ Guarantees the operation of the systems in case of vandalism
- ~ Prevents interventions to reset cameras
- ~ Lithium backup; 10 years without maintenance
- ~ Maintains applications operational 24/7

Main software specifications

- ~ Layer 2 management: VLAN, Spanning Tree, STP, RSTP, Loop Protection, Aggregation, Mirroring, QoS, LLDP, 802.1x, IGMP Snooping, DHCP Snooping, Port Security, ARP, ACL, and more...
- ~ Device Activity Monitoring
- ~ Green Ethernet
- ~ Secure management with HTTPS and SNMP V3
- ~ Jumbo Frames 9.6 kilobytes

Main hardware specifications

- ~ 20 Ethernet ports (PoE/PoE+) 10/100/1000 Mbps
- ~ 2 SFP ports 100/1000 Mbps
- ~ 2 combo ports (Ethernet/SFP)
- ~ PoE budget 210 W
- ~ Lithium LFP battery, 72 Wh or 144 Wh
- ~ 2U metal rack: W446 x H85 x D380 [mm]
- ~ IP30
- ~ Weight, depending on the model: 7 kg or 7.7 kg

MODEL	WEIGHT (kg)	SIZE W x H x D (mm)	CODE
SDC-POE 24			
SDC-POE 6F RK2 P24	7.0 kg	446 x 85 x 380	83962307
SDC-POE 6J RK2 P24	7.7 kg	446 x 85 x 380	83965307

SNMP / BACnet IP communication

SDC-PoE 24 is a PoE / PoE + managed layer 2+ switch, with built-in micro-UPS function (Lithium LFP battery). With 24 full-Gigabit ports including 4 SFP ports for fiber links, the switch interconnects and supplies equipments, such as cameras, recorders, alarm panels, etc. It manages data or video flows and monitors the proper functioning of the devices. In the event of a power failure, it ensures service continuity, and maintains operation of the equipments powered by PoE / PoE +.

> Mechanical characteristics					
Boxes	Size W x H x D (mm)	Weight (kg)	Materials	Protection rating	Installation
 Rack 2U	446 x 85 x 380 (without connectors)	7 - 7.7	Painted metal	IP30	Rack / Shelf placement
Connections					
Mains	IEC connector				
PoE ports	20 RJ45 ports	Ethernet cable Cat 5 or more / shielded / straight or twisted cables			
SFP ports	2 SFP ports	SFP module 1000 Mbps transceiver			
Combo ports	2 Combo ports PoE/SFP				
> Switch properties					
Priority Queues	8				
Max. Number of VLANs	4094				
VLAN ID Range	VID 1 to 4094				
IGMP Groups	1024				
MAC Table Size	Up to 8K MAC addresses				
Jumbo Frame Size	9.6 KB				
Performance					
Capacity of the forwarding rate in Millions of Packets per Second (Mpps) (64-byte packets)	38.69 Mpps				
Switching Capacity in Gigabits per Second (Gbps)	52 Gbps				
> Switching characteristics					
Layer 2 Switching					
Spanning Tree Protocol (STP)	Standard Spanning Tree 802.1d				
	Rapid Spanning Tree (RSTP) 802.1w				
Aggregation	Link Aggregation Control Protocol (LACP) IEEE 802.3ad; Up to 12 groups ; Up to 16 ports per group				
VLAN	Supports up to 4K VLANs simultaneously (out of 4094 VLAN IDs) ; Port-based VLAN; 802.1Q tag-based VLAN				
IGMP v1/v2 Snooping	IGMP limits bandwidth-intensive multicast traffic to only the requesters; it supports 1024 multicast groups (source-specific multicasting is also supported)				
Security					
Secure Sockets Layer (SSL), HTTPS	SSL encrypts the http traffic, allowing advance secure access to the browser-based management GUI in the switch				
Port Security	Locks MAC Addresses to ports, and limits the number of learned MAC addresses				
IP Source Guard (IPSG)	Prevents datagram with spoofed addresses from being in the network				
Storm Control	Prevents traffic on a LAN from being disrupted by a broadcast, multicast or unicast storm on a port				
ACLs	Supports for up to 256 entries; Drop or rate limitation based on source and destination MAC, VLAN ID or IP address, protocol, port, differentiated services code point (DSCP) / IP precedence, TCP/ UDP source and destination ports, 802.1p priority, Ethernet type, Internet Control Message Protocol (ICMP) packets, IGMP packets, TCP flag				

> Switching characteristics			
Quality of Service			
Hardware Priority Queue	Supports 8 hardware queues		
Scheduling	Strict priority and weighted round-robin (WRR)		
	Queue assignment based on DSCP and class of service (802.1p/ CoS)		
Classification	Port based; 802.1p VLAN priority based; IPv4 precedence/ type of service (ToS) / DSCP based		
Rate Limiting	Ingress policer; egress shaping and rate control; per VLAN, per port and flow based		
Management (Web/SSL, SNMP, BACnet)			
Web GUI interface	Built-in switch configuration utility for browser-based device configuration (HTTPS). Supports configuration, system dashboard, maintenance and monitoring.		
Firmware upgrade	Web browser upgrade (HTTPS)		
Port Mirroring	Traffic on a port can be mirrored to another port for analysis with a network analyzer or RMON probe. Up to N-1 (N is Switch's Ports) ports can be mirrored to a single destination port. A single session is supported.		
Other management	Single IP management; HTTPS; RADIUS; DHCP Client; SNMP; cable diagnostics		
Green Ethernet			
Link Detection	Compliant IEEE802.3az Energy Efficient Ethernet Task Force. Automatically turns off power on Gigabit Ethernet RJ-45 port when detecting link down or Idle of client. Active mode is resumed without loss of any packets when the switch detects the link up.		
Cable length Detection	Adjusts the signal strength based on the cable length. Reduces the power consumption for shorter cables.		
Eco Mode	Shifts automatically to power-saving mode.		
Discovery			
Link Layer Discovery Protocol (LLDP)	Used by network devices for advertising their identities, capabilities and neighbors on a IEEE 802 local area network, principally wired Ethernet.		
The configuration of the switch functions is done via the embedded website.			
> PoE			
PoE Ports	22 ports support PoE Power Pin Type: End-span (Mode A)		
PoE standard	IEEE 802.3af/at		
	15 W / 30 W per port		
Power	Per port PoE function configuration		
PoE budget	210 W		
Output (Smart Backup)	η @ 25% loading	η @ 75% loading	η @ 100% loading
	90.60%	94.50%	94.60%
> Minimum requirements			
Web browser	Mozilla Firefox version 2.5 or later, Microsoft Internet Explorer version 6 or later		
Network cable	Ethernet cable Cat 5e or more / shielded or unshielded / straight or twisted		
Rack mounting	Rail to place the product in the bay		
> Communication			
Communication speed	PoE ports	10 / 100 / 1000 Mbps	
	SFP ports	100 / 1000 Mbps	
	Combo ports	either 10 / 100 / 1000 Mbps (PoE) or 100 / 1000 Mbps (SFP)	
Application layer protocols	HTTPS, BACnet IP, SNMP, DHCP		
Network layer protocols	IPv4, ICMP		

> Signaling		
1 LED for the "PoE Load" level on the front panel		
1 LED for the product "Status" on the front panel		
22 LEDs indicate the PoE activity of each port on the front panel		
22 LEDs indicate the data transmission activity on the corresponding port in 100 Mbps (yellow)		
22 LEDs indicate the data transmission activity on the corresponding port in 1 Gbps (green)		
> Environmental specifications		
Temperature		
Storage	-20°C à +45°C	
Operating	at 100% load: -10°C ... +45°C	
	at 75% load: -10°C ... +50°C	
Humidity		
Storage	relative humidity 10% to 90%	
Operating	relative humidity 20% to 85%	
Altitude		
Above 2,000 m, the temperature decreases by 5% every 1,000 m.		
Cooling		
The cooling is carried out transversally.		
MTBF		
100,000 h (with battery) and 200,000 h (without battery) at 25 °C product external environment, rated mains voltage, 75% load		
> Electrical characteristics		
Network Input		
AC network voltage	198 to 264 V AC	
Frequency	45 to 65 Hz	
Class	Class 1	
Inrush current	Limited by NTC	
Neutral system	TT, TN, IT	
Protection against	primary short-circuit and differential mode shock waves	
Primary current @ 198 V	2 A	
Primary current @ 264 V	2 A	
Functional characteristics		
Operates in power-saving mode when the backup is charged.		
On/Off function per PoE port.		
Filters disturbances of the electrical network.		
Fan-cooling.		
Configurable reboot function (stop and restart automatically) on each PoE-port.		
Indicates the % of the remaining autonomy.		
Protections		
Against surge and overvoltage on primary (Lightning or industrial origins).		
Against overload by power limitation to $P_n+10\%$.		
Against overcurrent and short-circuits on the output by disconnecting the PoE port at $I > I_n + 10\%$.		
Smart Backup		
SDC-PoE 24 is available in 2 backup packs	6F	6J
Latest generation Lithium LiFePO4 Technology (no risk of thermal runaway).		
Lead-free, cadmium-free, 100% recyclable.		
Storage: 9 months without recharging.		
10 year service life.		
Advanced management settings, cell balancing, overload and overvoltage protection.		

Backup duration according to output power		
Operating power	Backup 6F	Backup 6J
	Autonomy expressed in hours and minutes	
10 W	1h35	3h10
20 W	1h12	2h24
30 W	0h58	1h56
40 W	0h48	1h37
50 W	0h41	1h23
60 W	0h36	1h13
70 W	0h32	1h04
80 W	0h29	0h58
90 W	0h26	0h52
100 W	0h24	0h48
110 W	0h22	0h44
120 W	0h20	0h41
130 W	0h19	0h38
140 W	0h17	0h35
150 W	0h16	0h33
160 W	0h15	0h31
170 W	0h14	0h29
180 W	0h14	0h28
190 W	0h13	0h27
200 W	0h12	0h25
210 W	0h12	0h24

> Standards

IEEE standards

IEEE 802.1D	Standard Spanning Tree
IEEE 802.1W	Rapid Spanning Tree (RSTP)
IEEE 802.1Q	VLAN
IEEE 802.1X	Radius
IEEE 802.3AD	Link Aggregation Control Protocol (LACP)
IEEE 802.3I	10BaseT
IEEE 802.3u	100BaseT(X) and 100BaseFX
IEEE 802.3ab	1000BaseT(X)
IEEE 802.3z	1000BaseX
IEEE 802.3x	Flow Control
IEEE 802.3af	PoE
IEEE 802.3at	PoE+
IEEE 802.3az	Energy Efficient Ethernet

Electrical standards

Safety	• EN IEC 62368-1 (2020) + A11 (2020)
EMC - Immunity	• EN IEC 61000-6-1 (2019) • EN IEC 61000-6-2 (2019)
EMC - Emissions	• EN IEC 61000-6-3 (2021) • EN IEC 61000-6-4 (2019)
	• EN IEC 61000-3-2 (2019) (class A) • EN 55032 (2015) (class B)



Security

Transportation security	UN 38.3
-------------------------	---------

> Product references

Interpretation of the product reference designations: SDC-POE [Backup] RK2 P24

*SLAT reserves the right to modify the characteristics of its products without prior notice.

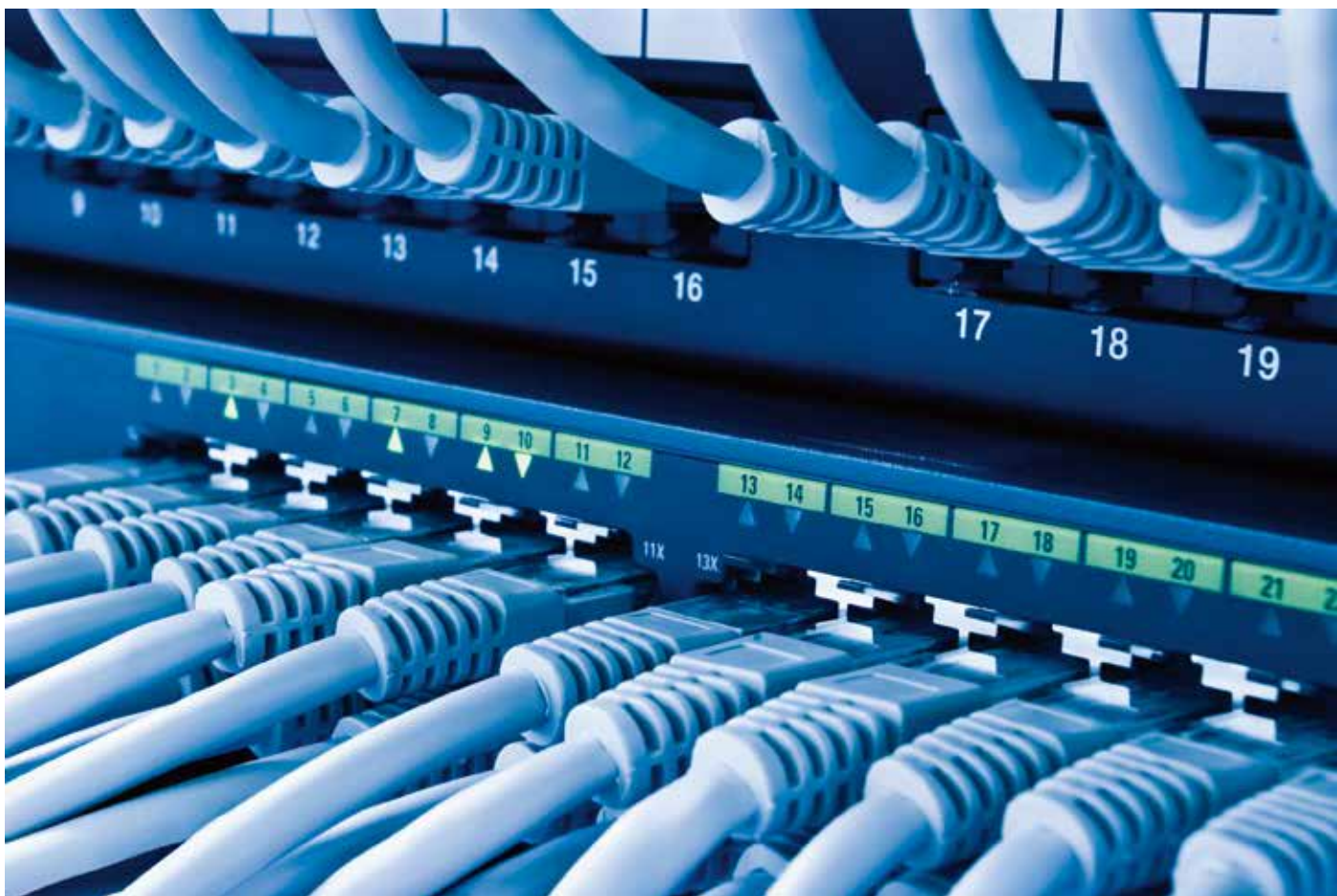

Defining your lead battery's capacity

For systems requiring backup, you must first determine:

- ~ The **rated operating voltage, U_n** (in Volts)
- ~ The system's **continuous drain current, I_n** (in Amperes), or the **continuous power input, P_n** (in Watts)
- ~ The **battery autonomy required** by the customer, **t** (in hours)
- ~ The **adjustment factor K** according to the cutoff 1.85V/cell and the battery autonomy

Define your adjustment factor K according to the required battery autonomy:

Required battery autonomy in hours (t)	Factor (K)
20	1.10
12	1.15
8	1.25
4	1.56
2	1.66
1	2
0.5 (30 min)	2.5
0.33 (20 min)	3
0.16 (10 min)	4

Note that, if you have the continuous power input P_n (in Watts), below is the calculation to obtain the continuous drain current I_n (in Amperes):

$$I_n [\text{Ampere}] = P_n [\text{Watt}] / U_n [\text{Volt}]$$

Perform the following calculation to define C_{Ah} , i.e. the required battery capacity in Ampere-hours:

$$C_{Ah} = I_n \times t \times K$$

(important: this formula is applicable to systems with a continuous output and a cutoff of 1.85V/cell)

Example :

$$U_n = 24 \text{ V}$$

$$I_n = 4 \text{ A}$$

Required battery autonomy: 4 h

$$C_{Ah} = I_n \times t \times K$$

$$C_{Ah} = 4 \times 4 \times 1.56 = 24.96$$

I.e. a maximum capacity of: **24 Ah.**

Choosing a charger's rating

To perform this calculation, you must know:

- ~ The **rated operating voltage, U_n** (in Volts)
- ~ The system's **continuous drain current, I_n** (in Amperes), or the **continuous power input, P_n** (in Watts)
- ~ The associated **battery capacity** to maintain, **C_{Ah}** (see previous calculations)

Perform the following calculation to determine the current of the charger :

$$\text{Charger rating} = I_n + (C_{Ah}/10)$$

Example :

$$I_n = 4 \text{ A}$$

$$C_{Ah} = 24 \text{ Ah}$$

$$\text{Charger rating} = 4 + (24/10) = 6.4$$

I.e. a charger rating greater than or equal to **6.4 A.**

Batteries



PBE FRONT TERMINAL



MODEL	WEIGHT (kg)	SIZE W x H x D	CODE
BAT PBE 12V 2Ah	1,0 kg	178 x 64 x 34	9729120021
BAT PBE 12V 7Ah	2,7 kg	151 x 97,5 x 65	9729120060
BAT PBE 12V 12Ah	4,1 kg	151 X 97,5 x 100	9729120120
BAT PBE 12V 17Ah	6,4 kg	181 x 76 x 167	9729120150
BAT PBE 12V 24Ah	9,7 kg	166 x 175 x 125	9729120240
BAT PBE 12V 38Ah	14,5 kg	197 x 170 x 165	9729120380
BAT PBE 12V 65Ah	24,0 kg	350 x 174 x 166	9729120650
BAT PBE 12V 95Ah	33,2 kg	302 x 227 x 175	9729120850
BAT PBE 12V 130Ah M8	38,0 kg	410 x 225 x 177	9729121100

* The batterie capacities are indications. They may vary according to the supplier.



MODEL	WEIGHT (kg)	SIZE W x H x D	CODE
COFFRET BATTERIE NU BA.MC	5,0 kg	289 x 350 x 189	9069000115
COFFRET BATTERIE ABM 1P	12,0 kg	505 x 610 x 300	9069002011
COFFRET BATTERIE ABM 1G	16,0 kg	505 x 610 x 430	9069002012

Battery capacity according to cabinet

Enclosure	Dimensions W x H x D (mm)	Mounting	12 V	24 V	48 V	56 V
C7	243 x 195 x 96	Wall-mounted & DIN rail	7 Ah	1.2 Ah	2.1 Ah	-
C24	322 x 248 x 126	Wall-mounted	7 Ah 12 Ah 24 Ah (2 x 12 Ah)	7 Ah 12 Ah	2.1 Ah	-
C38	289 x 350 x 189	Wall-mounted & floor-mounted	17 Ah 24 Ah 38 Ah	17 Ah 24 Ah	7 Ah 12 Ah	-
C48	425 x 345 x 120	Wall-mounted	24 Ah (2 x 12 Ah) 36 Ah (3 x 12 Ah) 48 Ah (4 x 12 Ah)	7 Ah 12 Ah 24 Ah (4 x 12 Ah)	7 Ah 12 Ah	7 Ah 12 Ah
C85	408 x 408 x 224	Wall-mounted & floor-mounted	48 Ah (2 x 24 Ah) 65 Ah 96 Ah (4 x 24 Ah)	24 Ah 38 Ah 48 Ah (4 x 24 Ah)	12 Ah 17 Ah 24 Ah	-
C180	505 x 610 x 430	Floor-mounted	120 Ah 130 Ah 140 Ah	65 Ah 95 Ah 120 Ah 130 Ah 170 Ah	38 Ah 65 Ah 95 Ah	-

After-sales solutions

after.sales@slat.fr

HOTLINE + 33 478 66 63 70

Your online technical support

1. Your products are under warranty

For the simplest and quickest solution for the maintenance of your products under warranty:

- Contact our After Sales Department using the form on www.slat.com in your personal MySLAT space, please be sure to fill out all the required fields.
- Your Account Manager will process your request and send you the RMA form by email.
- On receipt of the RMA form, please send back two copies along with your product(s), one should be placed inside the package and the other on the outside of the package for warehouse identification. This will ensure your product can be traced.
- The repaired or replacement product(s) will be returned within 15 working days.

2. Your products are no longer under warranty

We offer two product maintenance solutions:

QUICK AND EASY: replace the equipment yourselves

- You do not need to send the equipment back.
- Order your maintenance board at the standard rate and receive delivery within one week. Contact our Customer Services Department for advice by filling out the contact form on www.slat.com in your personal MySLAT space.
- Your new boards come with a one-year warranty.

Have our experts repair your products

- If you prefer this option, please use the following procedure to obtain an RMA number:
- Contact our Customer Service Department using the form on www.slat.com in your personal MySLAT space, please be sure to fill out all the required fields.
- Your Account Manager will send you your RMA form along with the quote for the appropriate product range.
- On receipt of the RMA form, please send back two copies along with your product(s), one should be placed inside the package and the other on the outside of the package for warehouse identification. This will ensure your product can be traced. The repair work will only be carried out after the signed quote is received along with a repair order. If you do not wish to accept the quote, please return it to: service.client@slat.fr, marked as "refused" and specify if we should destroy the equipment or return it as is (in this case a €150 handling fee will be charged).
- The repaired or replacement product(s) will be returned within 15 working days. Your product will be covered by a new 3-month warranty..

Conditions: The Return Merchandise Authorisation is delivered by SLAT.

An RMA number is allocated to each product to be returned. Each RMA number is valid for a 30-day period.

No returns can be accepted without prior obtention of an RMA number.



Spare parts

MODEL	WEIGHT (kg)	SIZE W x H x D (mm)	CODE
CL 12V 2A CARTE	0.1 kg	99 x 68 x 35	1020210000
CL 12V 5A CARTE	0.2 kg	99 x 85 x 35	1020510000
CL 24V 2.5A CARTE	0.2 kg	99 x 85 x 35	1040210000
CL 24V 4A CARTE	0.5 kg	158 x 112 x 47	1040410000
CL 24V 6A CARTE	0.5 kg	158 x 112 x 47	1040610000
CL 48V 2A CARTE	0.5 kg	158 x 112 x 47	1080210000
CL 48V 3A CARTE	0.5 kg	158 x 112 x 47	1080310000
EV 12V 6A CARTE	0.5 kg	98 x 170 x 54	1520610000
EV 12V 8A CARTE	1.5 kg	158 x 112 x 47	1520810000
EV 12V 12A CARTE	2.5 kg	158 x 112 x 47	1521210000
EV 12V 16A CARTE	0.5 kg	220 x 162 x 48	1521610000
EV 12V 24A CARTE	1.3 kg	220 x 162 x 48	1522410000
EV 12V 32A CARTE	2.3 kg	197 x 252 x 61	1523210000

Spare parts (continued)

MODEL	WEIGHT (kg)	SIZE W x H x D (mm)	CODE
EV 24V 3A CARTE	0.5 kg	98 x 170 x 54	1540310000
EV 24V 4A CARTE	0.5 kg	158 x 112 x 47	1540410000
EV 24V 6A CARTE	0.5 kg	158 x 112 x 47	1540610000
EV 24V 8A CARTE	0.5 kg	220 x 162 x 48	1540810000
EV 24V 12A CARTE	1.3 kg	220 x 162 x 48	1541210000
EV 24V 16A CARTE	2.3 kg	197 x 252 x 61	1541610000
EV 24V 24A CARTE	2.3 kg	197 x 252 x 61	1542410000
EV 48V 2A CARTE	0.5 kg	158 x 112 x 47	1580210000
EV 48V 3A CARTE	0.5 kg	158 x 112 x 47	1580310000
EV 48V 4A CARTE	0.5 kg	220 x 162 x 48	1580410000
EV 48V 6A CARTE	1.4 kg	220 x 162 x 48	1580610000
EV 48V 8A CARTE	1.4 kg	197 x 252 x 61	1580810000
EV 48V 12A CARTE	2.3 kg	197 x 252 x 61	1581210000
AES 24V 4A CARTE	0.5 kg	158 x 112 x 47	2040410000
AES 24V 6A CARTE	0.5 kg	158 x 112 x 47	2040610000
AES 24V 8A CARTE	0.5 kg	220 x 162 x 48	2040810000
AES 24V 12A CARTE	0.5 kg	158 x 112 x 47	2041210000
AES 24V 16A CARTE	2.3 kg	197 X 252 X 61	2041610000
AES 24V 24A CARTE	2.3 kg	197 X 252 X 61	2042410000
AES 48V 2A CARTE	0.5 kg	158 x 112 x 47	2080210000
AES 48V 3A CARTE	0.5 kg	158 x 112 x 47	2080310000
AES 48V 4A CARTE	0.5 kg	220 x 162 x 48	2080410000
AES 48V 6A CARTE	1.4 kg	220 x 162 x 48	2080610000
AES 48V 8A CARTE	1.4 kg	162 X 220 X 65	2080810000
AES 48V 12A CARTE	2.3 kg	197 X 252 x 61	2081210000
ACCES 12V 6A CARTE	1.0 kg	98 x 170 x 54	2520610000
ACCES 12V 8A CARTE	1.0 kg	158 x 112 x 47	2520810000
ACCES 12V 12A CARTE	1.0 kg	158 x 112 x 47	2521210000
ACCES 24V 4A CARTE	1.0 kg	158 x 112 x 47	2540410000
ACCES 24V 6A CARTE	1.0 kg	158 x 112 x 47	2540610000
SANTE 24V 4A CARTE	1.0 kg	158 x 112 x 47	3040410000
SANTE 24V 8A CARTE	1.0 kg	220 x 162 x 48	3040810000
SANTE 24V 12A CARTE	1.3 kg	220 x 162 x 48	3041210000
SANTE 24V 16A CARTE	1.4 kg	220 x 162 x 48	3041610000
SANTE 24V 24A CARTE	2.3 kg	220 x 162 x 48	3042410000
AXS3 12V 4A CARTE	0.5 kg	130 x 104 x 41	2620410000
AXS3 12V 6A CARTE	0.5 kg	130 x 104 x 41	2620610000
AXS3 24V 2A CARTE	0.5 kg	130 x 104 x 41	2640210000
AXS3 24V 3A CARTE	0.5 kg	130 x 104 x 41	2640310000
AXS2 12V 2A CARTE	0.1 kg	99 x 68 x 35	2720205000
AXS2 12V 5A CARTE	0.2 kg	99 x 85 x 35	2720505000
AXS2 12V 10A CARTE	1.0 kg	158 x 112 x 47	2721010000
AXS2 24V 1A CARTE	0.1 kg	99 x 68 x 35	2740105000
AXS2 24V 2.5A CARTE	0.2 kg	99 x 85 x 35	2740205000
AXS2 24V 5A CARTE	1.0 kg	158 x 112 x 47	2740510000
OPTION KIT 3 DEPARTS FUSIBLES	-	-	9900080000
OPTION CARTE 5 DEPARTS FUSIBLES	-	-	9059050004
PM CARTE EMBASE EP	-	-	4891000000
PM Carte VISU NG SAV	-	-	8000000000

Repair Package

SERVICE	TERM	RATING	CODE
Forfait de réparation A	Repair package A	12V 2A / 12V 5A / 24V 1A / 24V 2,5A	9005013
Forfait de réparation B	Repair package B	12V 6A / 12V 8A / 12V 12A / 24V 3A / 24V 4A / 24V 6A / 48V 1,5A / 48V 2A / 48V 3A	9005012
Forfait de réparation C	Repair package C	12V 16A / 12V 24A / 24V 8A / 24V 12A / 48V 4A / 48V 6A	9005011
Forfait de réparation D	Repair package D	12V 32A / 12V 48A / 24V 16A / 24V 24A / 48V 8A / 48V 12A	9005010
Forfait de réparation E	Repair package E	48V 16A / 48V 25A / 48V 40A	9005009

The packages are exclusive to the caliber of the products shown in the price list.
The products which have more than 10 years and product which underwent physical damage (liquid, lightning, etc.) are consistently reported irreparable.



MASTERED ENERGY

Reliable, innovative power supply solutions, in phase with their time and your everyday life.

SLAT SAS
7 B, rue Jean Elysée Dupuy
69410 Champagne au Mont d'Or
France
Tel. +33 478 66 63 60
comm@slat.fr

SLAT GmbH
Leitzstraße 45,
70469 Stuttgart
Deutschland
Tel. +49 711 899 890 08
info@slat-gmbh.de